



We Tame Photons to Work for You!



Products

Search Tools

Solutions

Literature

Tech Notes

Support

Corporate

Products > LED Indicators > Panel Indicators > Round > Front Insertion > 3mm > Chrome Housing > Protruding LED

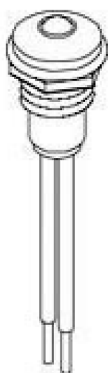

Features / Options

- ▶ Bi-Color Styles Optional
- ▶ State-of-the-Art, LED Technology
- ▶ Choice of LED Colors and Lens Finishes
- ▶ Insulated Lead Lengths Optional
- ▶ Easy installation through panel

Applications / Uses

- ▶ Front Panel Status Indicators
- ▶ Alarm/Warning Indicators
- ▶ Front Panel Circuit Fault Indicators
- ▶ Instrument Control Panels
- ▶ Medical Diagnostics Indicators
- ▶ Industrial Automation Control Panels

Part Number:	Brightness	Material	Emitted Color	Wavelength	Intensity	View Angle	Voltage
SSI-LXR3612BID-150	STANDARD	GaAsP	Red	635	6	60	3-15V
SSI-LXR3612GD-150	STANDARD	GaP	Green	565	30	60	2.2
SSI-LXR3612GD5V150	STANDARD	GaP	Green	565	15	60	5.0
SSI-LXR3612HGW-150	STANDARD	GaP	Red/ Green	700/565	5/20	60	2.0/2.2
SSI-LXR3612ID-150	STANDARD	GaAsP	Red	635	30	60	2.0
SSI-LXR3612ID5V150	STANDARD	GaAsP	Red	635	10	60	5.0
SSI-LXR3612SID-150	HIGH	AlInGaP	Red	636	100	60	2.1
SSI-LXR3612SOD-150	HIGH	AlInGaP	Orange	610	100	60	2.1
SSI-LXR3612SRD-150	HIGH	GaAlAs	Red	660	65	60	1.8
SSI-LXR3612SUGD150	HIGH	AlInGaP	Green	574	70	60	2.2
SSI-LXR3612SYD-150	HIGH	AlInGaP	Yellow	590	100	60	2.1

SSI-LXR3612USBD-150		HIGH	InGaN	Blue	470	60	60	3.5
SSI-LXR3612YD-150		STANDARD	GaAsP	Yellow	585	30	60	2.1
SSI-LXR3612YD5V150		STANDARD	GaAsP	Yellow	585	10	60	5.0

UNCONTROLLED DOCUMENT

PART NUMBER		REV.
SSI-LXR3612ID-150		E
REV.	E.C.N. NUMBER AND REVISION COMMENTS	DATE
A	UPDATED SAFE OPER. SPECS.	11.17.92
B	UPDATED SAFE OPER. SPECS AND NOTES.	9.19.94
C	UPDATED DWG AND NOTES.	5.16.95
D	CHG'D WIRE SIZE.	6.23.95
E	E.C.N. #10BRDR. & REDRAWN IN 3D.	10.30.01

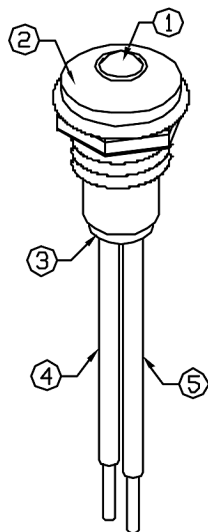
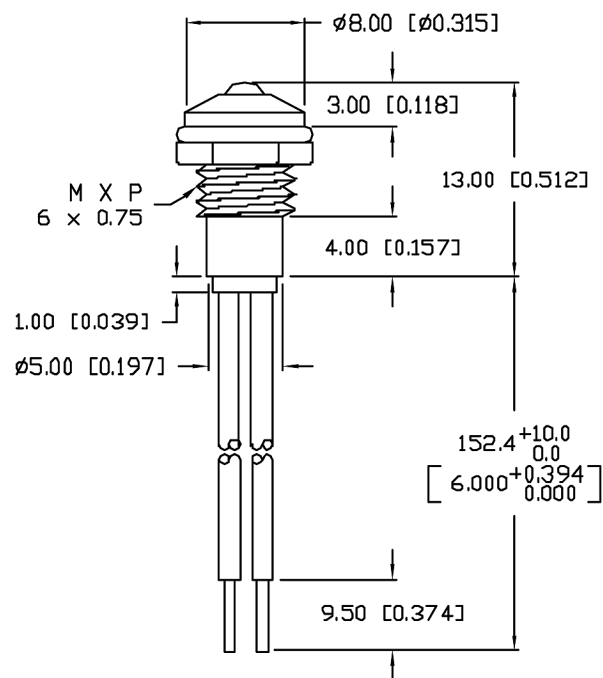

PANEL CUTOUT

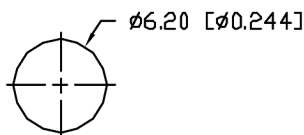

NOTES:

1. SSL-LX3054ID, RED LED, TRIM LEADS TO 5mm.
2. SSI-LXR3612 HOLDER, CHROME FINISH.
3. SSH-LXH1612BSC, BUSHING, INSERT AND CRIMP.
4. ANODE LEAD: LXP-WST26RDT0C, 26 AWG. STRANDED, RED INSULATION, CUT TO 157mm LONG, STRIP ENDS 2mm AND 9.5mm.
5. CATHODE LEAD: LXP-WST26BLT0C, 26 AWG. STRANDED, BLACK INSULATION, CUT TO 157mm LONG, STRIP ENDS 2mm AND 9.5mm.
6. SOLDER LED LEADS TO WIRE LEADS.

ELECTRO-OPTICAL CHARACTERISTICS $T_A=25^{\circ}\text{C}$ $I_f=20\text{mA}$

PARAMETER	MIN	TYP	MAX	UNITS	TEST COND
PEAK WAVELENGTH		635		nm	
FORWARD VOLTAGE		2.0	2.5	V_f	
REVERSE VOLTAGE	5.0			V_r	$I_f=100\mu\text{A}$
AXIAL INTENSITY		30		mcd	$I_f=20\text{mA}$
VIEWING ANGLE		60		2x theta	
EMITTED COLOR:	RED				
EPOXY LENS FINISH:	RED DIFFUSED				

LIMITS OF SAFE OPERATION AT 25°C

PARAMETER	MAX	UNITS
PEAK FORWARD CURRENT*	150	mA
STEADY CURRENT	30	mA
POWER DISSIPATION	105	mW
DERATE FROM 25°C	-1.6	mW/°C
OPERATING, STORAGE TEMP.	-40 TO +85	°C

* $t < 10\mu\text{s}$

*UNLESS OTHERWISE SPECIFIED TOLERANCES PER DECIMAL PRECISION ARE: X=±1 (±0.039), XX=±0.5 (±0.020), XXX=±0.25 (±0.010), XXXX=±0.127 (±0.005). LEAD SIZE=±0.05 (±0.002), LEAD LENGTH=±0.75 (±0.030), MIN.=^{+0.00}/_{-0.00} DECIMAL PRECISION, MAX.=^{+0.00}/_{-0.00} DECIMAL PRECISION

UNCONTROLLED DOCUMENT

REV.	PART NUMBER
E	SSI-LXR3612ID-150

CONFIDENTIAL INFORMATION
 THE INFORMATION CONTAINED IN THIS DOCUMENT IS THE PROPERTY OF LUMEX INC. EXCEPT AS SPECIFICALLY AUTHORIZED IN WRITING BY LUMEX INC, THE HOLDER OF THIS DOCUMENT SHALL KEEP ALL INFORMATION CONTAINED HEREIN CONFIDENTIAL AND SHALL PROTECT SAME IN WHOLE OR IN PART FROM DISCLOSURE AND DISSEMINATION TO ALL THIRD PARTIES.

RELIABILITY NOTE
 OUR MANY YEARS OF EXPERIENCE DATA ACCUMULATION INDICATE THAT SOLDER HEAT IS A MAJOR CAUSE OF EARLY AND FUTURE FAILURE. PLEASE PAY ATTENTION TO YOUR SOLDERING PROCESS.



T-3mm (T-1) 635nm RED LED PANEL INDICATOR,
 RED DIFFUSED LENS, WITH 6" WIRE LEADS.