

Optocoupler, Phototransistor Output, DIL-4 SMD Package

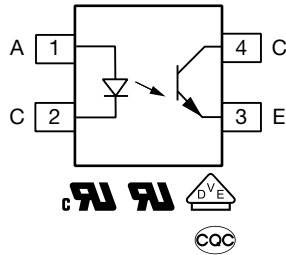

FEATURES

- High CTR at low forward current
- High collector emitter voltage, $V_{CE0} = 80\text{ V}$
- High isolation voltage, $V_{ISO} = 5000\text{ V}_{RMS}$
- Enhanced CTR linearity over temperature and forward current
- Operating temperature up to $125\text{ }^{\circ}\text{C}$
- Material categorization:
for definitions of compliance please see www.vishay.com/doc?99912

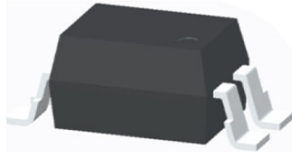

DESCRIPTION

The VO619A series has an infrared emitting diode, which is optically coupled to a phototransistor detector, and is incorporated in a green 4-pin DIL package. It features a high current transfer ratio at low input current with enhanced linearity over temperature. The coupling device is designed for signal transmission between two electrically separated circuits.

APPLICATIONS

- DC/DC converters
- Programmable controllers
- Power supplies
- Signal transmission with galvanic and noise isolation

AGENCY APPROVALS

(All parts are certified under base model VO619A)

- UL
- cUL
- DIN EN 60747-5-5 (VDE 0884-5)
- CQC

ORDERING INFORMATION																												
<table border="1" style="margin: auto;"> <tr> <td>V</td><td>O</td><td>6</td><td>1</td><td>9</td><td>A</td><td>-</td><td>#</td><td>X</td><td>0</td><td>0</td><td>1</td><td>T</td> </tr> <tr> <td colspan="7">PART NUMBER</td> <td>CTR BIN</td> <td colspan="3">PACKAGE OPTION</td> <td>TAPE AND REEL</td> </tr> </table>	V	O	6	1	9	A	-	#	X	0	0	1	T	PART NUMBER							CTR BIN	PACKAGE OPTION			TAPE AND REEL			
V	O	6	1	9	A	-	#	X	0	0	1	T																
PART NUMBER							CTR BIN	PACKAGE OPTION			TAPE AND REEL																	
AGENCY CERTIFIED / PACKAGE	CTR (%)																											
	0.5 mA																											
UL, cUL, CQC, VDE	100 to 250	160 to 320	200 to 400																									
SMD-4	VO619A-3X019T	VO619A-4X019T	VO619A-9X019T																									

Note

- Additional options may be possible, please contact sales office.



ABSOLUTE MAXIMUM RATINGS ($T_{amb} = 25\text{ }^{\circ}\text{C}$, unless otherwise specified)				
PARAMETER	TEST CONDITION	SYMBOL	VALUE	UNIT
INPUT				
Reverse voltage		V_R	6	V
Power dissipation		P_{diss}	50	mW
Forward current		I_F	30	mA
Surge forward current	$t_p \leq 1\text{ }\mu\text{s}$	I_{FSM}	1.0	A
Junction temperature		T_J	135	$^{\circ}\text{C}$
OUTPUT				
Collector emitter voltage		V_{CEO}	80	V
Emitter collector voltage		V_{ECO}	7	V
Collector current		I_C	30	mA
Power dissipation		P_{diss}	200	mW
Junction temperature		T_J	135	$^{\circ}\text{C}$
COUPLER				
Total power dissipation		P_{tot}	200	mW
Storage temperature range		T_{stg}	-55 to +125	$^{\circ}\text{C}$
Ambient temperature range		T_{amb}	-55 to +125	$^{\circ}\text{C}$
Soldering temperature ⁽¹⁾	$t = 10\text{ s}$	T_{sld}	260	$^{\circ}\text{C}$

Notes

- Stresses in excess of the absolute maximum ratings can cause permanent damage to the device. Functional operation of the device is not implied at these or any other conditions in excess of those given in the operational sections of this document. Exposure to absolute maximum ratings for extended periods of the time can adversely affect reliability.
- ⁽¹⁾ Refer to reflow profile for soldering conditions for surface mounted devices.

RECOMMENDED OPERATING CONDITIONS ($T_{amb} = 25\text{ }^{\circ}\text{C}$, unless otherwise specified)				
PARAMETER	SYMBOL	MIN.	MAX.	UNIT
Forward current	I_F	0.5	10	mA

ELECTRICAL CHARACTERISTICS ($T_{amb} = 25\text{ }^{\circ}\text{C}$, unless otherwise specified)						
PARAMETER	TEST CONDITION	SYMBOL	MIN.	TYP.	MAX.	UNIT
INPUT						
Forward voltage	$I_F = 10\text{ mA}$	V_F	-	-	1.6	V
Reverse current	$V_R = 6\text{ V}$	I_R	-	-	10	μA
OUTPUT						
Collector emitter leakage current	$V_{CE} = 20\text{ V}, I_F = 0\text{ mA}$		-	-	200	nA
Collector emitter breakdown voltage	$I_C = 0.5\text{ mA}$	BV_{CEO}	80	-	-	
Emitter-Collector breakdown voltage	$I_E = 0.1\text{ mA}$	BV_{ECO}	7	-	-	
COUPLER						
Collector emitter saturation voltage	$I_C = 2.4\text{ mA}, I_F = 8\text{ mA}$	V_{CEsat}	-	-	0.3	V

Note

- Minimum and maximum values are testing requirements. Typical values are characteristics of the device and are the result of engineering evaluation. Typical values are for information only and are not part of the testing requirements.

CURRENT TRANSFER RATIO ($T_{amb} = 25\text{ }^{\circ}\text{C}$, unless otherwise specified)							
PARAMETER	TEST CONDITION	PART	SYMBOL	MIN.	TYP.	MAX.	UNIT
I_C/I_F	$I_F = 0.5\text{ mA}, V_{CE} = 5\text{ V}$	VO619A-3	CTR	100	-	250	%
		VO619A-4	CTR	160	-	320	%
		VO619A-9	CTR	200	-	400	%

SWITCHING CHARACTERISTICS ($T_{amb} = 25\text{ }^{\circ}\text{C}$, unless otherwise specified)						
PARAMETER	TEST CONDITION	SYMBOL	MIN.	TYP.	MAX.	UNIT
Rise time	$V_{CE} = 2\text{ V}$, $I_C = 2\text{ mA}$, $R_L = 100\text{ }\Omega$	t_r	-	6	18	μs
Fall time	$V_{CE} = 2\text{ V}$, $I_C = 2\text{ mA}$, $R_L = 100\text{ }\Omega$	t_f	-	8	18	μs

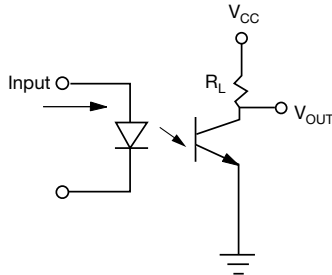
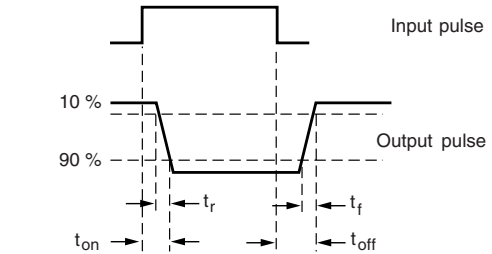

Fig. 1 - Test Circuit



isfh618a_12

Fig. 2 - Test Circuit and Waveforms

SAFETY AND INSULATION RATINGS				
PARAMETER	TEST CONDITION	SYMBOL	VALUE	UNIT
Climatic classification	According to IEC 68 part 1		55 / 125 / 21	
Pollution degree	According to DIN VDE 0109		2	
Comparative tracking index	Insulation group IIIa	CTI	175	
Maximum rated withstanding isolation voltage	According to UL1577, $t = 1\text{ min}$	V_{ISO}	5000	V_{RMS}
Maximum transient isolation voltage	According to DIN EN 60747-5-5	V_{IOTM}	6000	V_{peak}
Maximum repetitive peak isolation voltage	According to DIN EN 60747-5-5	V_{IORM}	850	V_{peak}
Isolation resistance	$T_{amb} = 25\text{ }^{\circ}\text{C}$, $V_{IO} = 500\text{ V}$	R_{IO}	$\geq 5 \times 10^{10}$	Ω
	$T_{amb} = T_S$, $V_{IO} = 500\text{ V}$	R_{IO}	$\geq 10^9$	Ω
Output safety power		P_{SO}	150	mW
Input safety current		I_{SI}	130	mA
Input safety temperature		T_S	150	$^{\circ}\text{C}$
Creepage distance			≥ 7	mm
Clearance distance			≥ 7	mm
Insulation thickness		DTI	≥ 0.4	mm

Note

- According to DIN EN 60747-5-5 (VDE 0884). This optocoupler is suitable for safe electrical isolation only within the safety ratings. Compliance with the safety ratings shall be ensured by means of suitable protective circuits.

TYPICAL CHARACTERISTICS ($T_{amb} = 25\text{ }^{\circ}\text{C}$, unless otherwise specified)

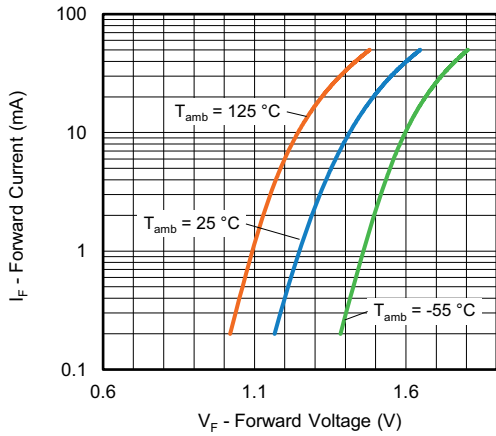

Fig. 3 - Forward Current vs. Forward Voltage

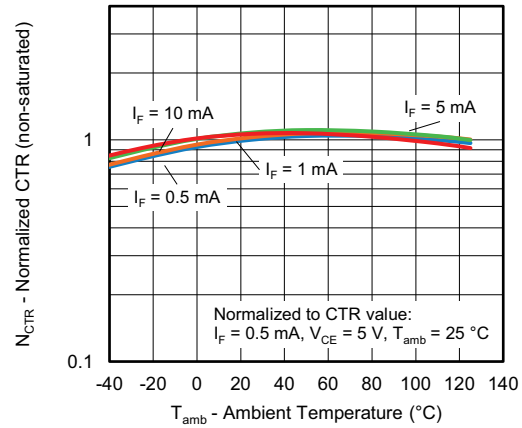

Fig. 6 - Normalized CTR vs. Ambient Temperature

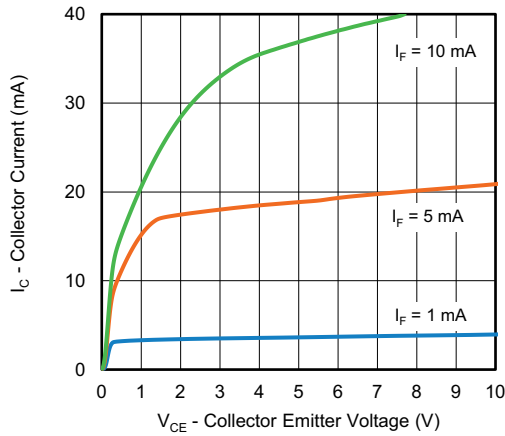

Fig. 4 - Collector Current vs. Collector Emitter Voltage (non-saturated)

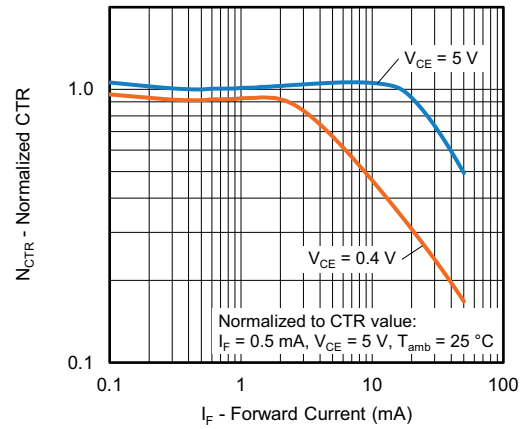

Fig. 7 - Normalized CTR vs. Forward Current

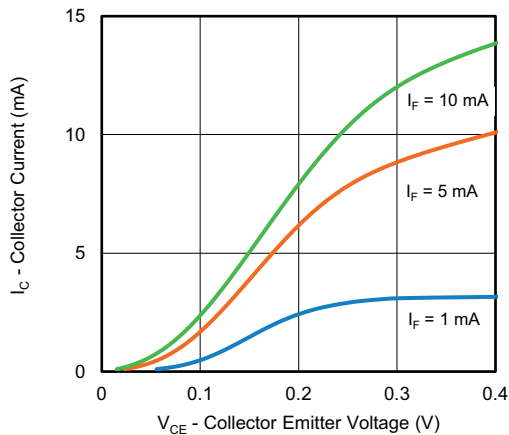

Fig. 5 - Collector Current vs. Collector Emitter Voltage (saturated)

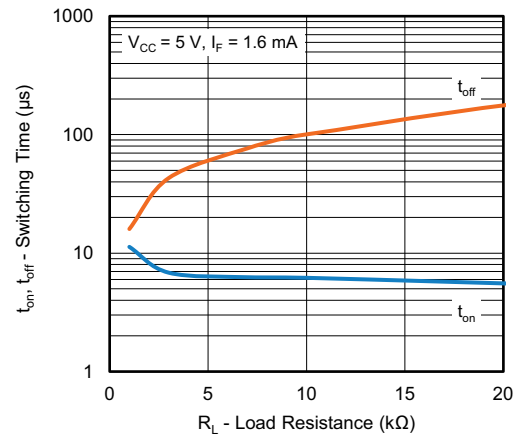

Fig. 8 - Switching Time vs. Load Resistance

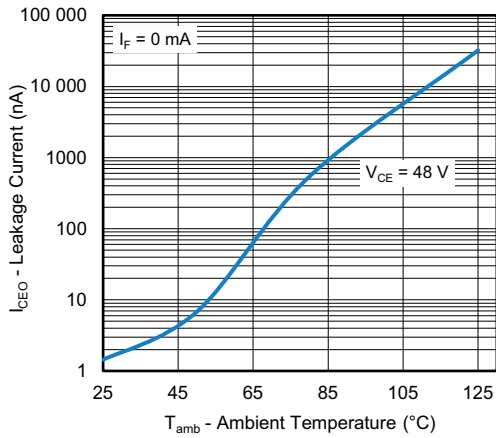
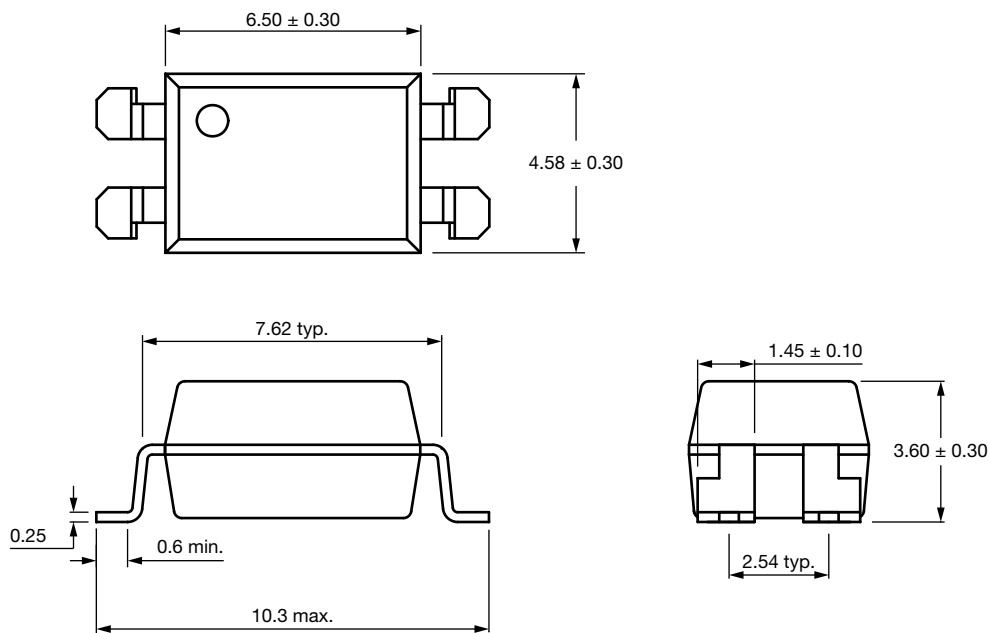
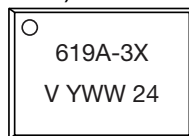

Fig. 9 - Leakage Current vs. Ambient Temperature

PACKAGE DIMENSIONS (in millimeters)



PACKAGE MARKING (example of VO619A-3X019T)



Notes

- Tape and reel suffix (T) is not part of the package marking
- YWW = date code

TAPE AND REEL DIMENSIONS (in millimeters)

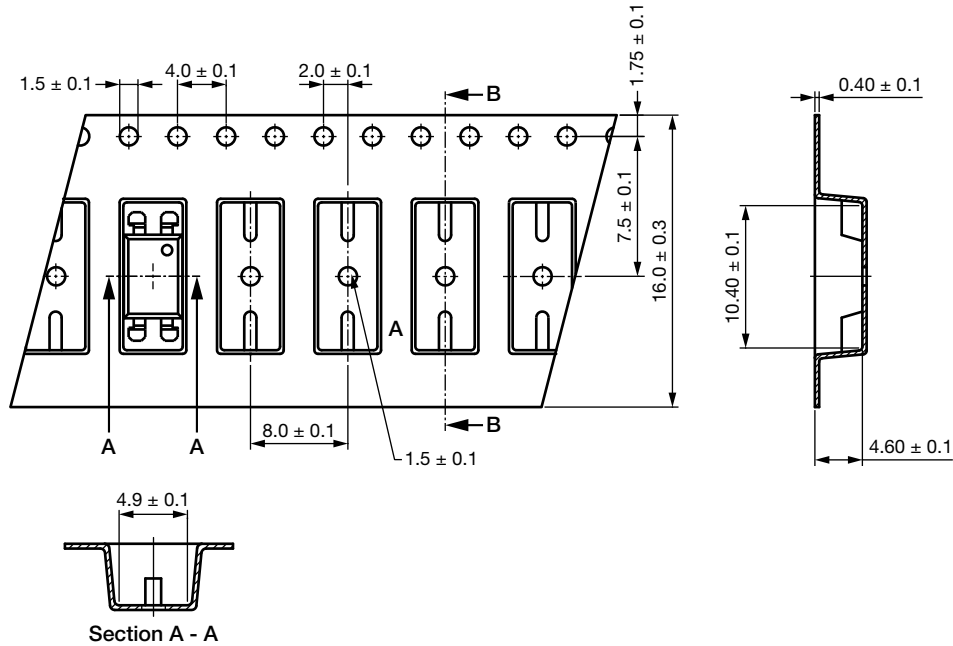
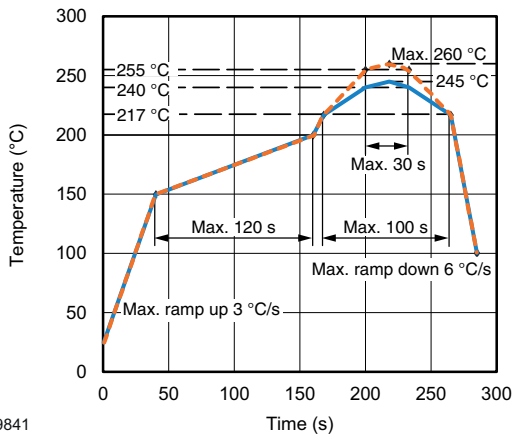

Fig. 10 - Tape and Reel Packing

TAPE AND REEL PACKING	
TYPE	UNITS/REEL
SMD-4	2000

SOLDER PROFILE



19841

Fig. 11 - Lead (Pb)-free Reflow Solder Profile According to J-STD-020

HANDLING AND STORAGE CONDITIONS

ESD level: HBM class 2

Floor life: unlimited

Conditions: $T_{amb} < 30\text{ °C}$, $RH < 85\%$

Moisture sensitivity level 1, according to J-STD-020



Disclaimer

ALL PRODUCT, PRODUCT SPECIFICATIONS AND DATA ARE SUBJECT TO CHANGE WITHOUT NOTICE TO IMPROVE RELIABILITY, FUNCTION OR DESIGN OR OTHERWISE.

Vishay Intertechnology, Inc., its affiliates, agents, and employees, and all persons acting on its or their behalf (collectively, "Vishay"), disclaim any and all liability for any errors, inaccuracies or incompleteness contained in any datasheet or in any other disclosure relating to any product.

Vishay makes no warranty, representation or guarantee regarding the suitability of the products for any particular purpose or the continuing production of any product. To the maximum extent permitted by applicable law, Vishay disclaims (i) any and all liability arising out of the application or use of any product, (ii) any and all liability, including without limitation special, consequential or incidental damages, and (iii) any and all implied warranties, including warranties of fitness for particular purpose, non-infringement and merchantability.

Statements regarding the suitability of products for certain types of applications are based on Vishay's knowledge of typical requirements that are often placed on Vishay products in generic applications. Such statements are not binding statements about the suitability of products for a particular application. It is the customer's responsibility to validate that a particular product with the properties described in the product specification is suitable for use in a particular application. Parameters provided in datasheets and / or specifications may vary in different applications and performance may vary over time. All operating parameters, including typical parameters, must be validated for each customer application by the customer's technical experts. Product specifications do not expand or otherwise modify Vishay's terms and conditions of purchase, including but not limited to the warranty expressed therein.

Hyperlinks included in this datasheet may direct users to third-party websites. These links are provided as a convenience and for informational purposes only. Inclusion of these hyperlinks does not constitute an endorsement or an approval by Vishay of any of the products, services or opinions of the corporation, organization or individual associated with the third-party website. Vishay disclaims any and all liability and bears no responsibility for the accuracy, legality or content of the third-party website or for that of subsequent links.

Vishay products are not designed for use in life-saving or life-sustaining applications or any application in which the failure of the Vishay product could result in personal injury or death unless specifically qualified in writing by Vishay. Customers using or selling Vishay products not expressly indicated for use in such applications do so at their own risk. Please contact authorized Vishay personnel to obtain written terms and conditions regarding products designed for such applications.

No license, express or implied, by estoppel or otherwise, to any intellectual property rights is granted by this document or by any conduct of Vishay. Product names and markings noted herein may be trademarks of their respective owners.