



26" PRO35™ ROLLER CABINET 6 DRAWERS RED

- Six fully extendable drawers with 30-40 kg capacity, compatible with TengTools Tool Control System for organized tool storage
- Drawers feature smooth running ball bearing slides and noise reducing EVA mats
- 5 mm EVA top mat provides a durable work surface
- Equipped with a 3-digit combination lock for secure storage
- 3-piece heavy gauge steel cabinet frame
- Treated with a phosphate free 5-step rust prevention process and powder coat finish

The TengTools 26" PRO35™ roller cabinet TSW26R6 with 6 drawers is a premium solution for mobile tool storage tailored for professional use. Measuring 680 mm in width, 460 mm in depth, and 813 mm in height (960 mm with castors), this roller cabinet is engineered to provide ample storage while maintaining a manageable footprint in various workspaces. This roller cabinet features six fully extendable drawers: five with a height of 75 mm and one larger drawer with a height of 312 mm. Each drawer is designed to hold any combination of TengTools modules with dimensions aligning with four TC1 modules plus a TCX4 module, thus allowing for a highly organized and efficient tool arrangement. The drawer capacity is 40 kg for each drawer, ensuring it can accommodate a wide range of tools and equipment. Enhancing its functionality, each drawer is fitted with smooth running ball bearing slides, providing reliable operation. The drawers are also equipped with EVA mats which protect tools, reduce noise, and maintain organization during movement. The top area of the cabinet features a 5 mm EVA top mat that makes for a stable and resilient work surface. Additionally, the cabinet is equipped with accessory holes on both sides enabling further customization to meet specific professional needs. For ease of movement and stability, the cabinet includes heavy-duty castors - two 5" braked swivel castors and two 5" fixed castors. A comfort grip handle on the side assists in maneuvering the cabinet around the workspace. Security is addressed with a 3-digit combination lock, providing peace of mind by safeguarding the contents. With its 3-piece heavy gauge steel cabinet frame and 5-step phosphate-free rust prevention process, this cabinet is built for durability.

General information

Country of origin: Taiwan
Barcode: 5020385215191
Tariff code Europe: 9403208000
ECCN US: EAR99
UNSPSC: 24112401

Dimensions

Net weight (g): 61785
Width (mm): 680
Depth (mm): 460
Height (mm): 813
Height with castors (mm): 960
Max static load: 530 kg
Max dynamic load: 330 kg
Number of drawer: 6
Drawer capacity: 7 × 40 kg
Drawer depth: 6 × 380 mm
Drawer height: 5 × 75 mm, 1 × 312 mm
Drawer width: 6 × 575 mm

Attributes

Product type: Mobile Tool Storage
Colour: Red
Type of storage: Roller cabinet
Castor size: 5" x 1-1/4"
Braked swivel castors: 2
Fixed castors: 2
Type of work top: 5 mm EVA mat

Features



Technical changes and errors may occur. 01-08-2024 20:00



DESIGNED IN SWEDEN

TengTools is a Swedish company present in more than 30 markets worldwide, and offers hand tools in smart storage solutions for demanding professionals within the automotive, maintenance and engineering sectors, as well as motor sport enthusiasts who aspire to use the same tools as top mechanics across the globe.



Sandbergsvägen 3
 441 39 Alingsås, Sweden

SPARE PART LIST

TSW26R6

Version: 3



WWW.TENGOOLS.COM

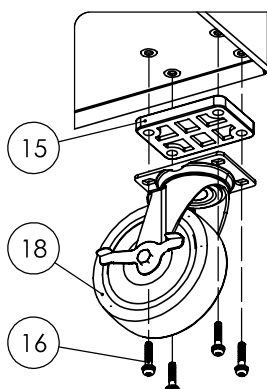
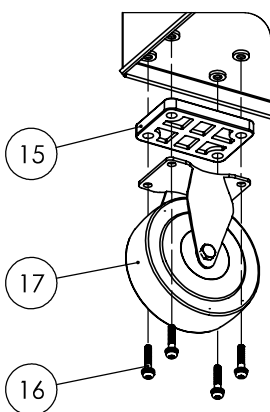
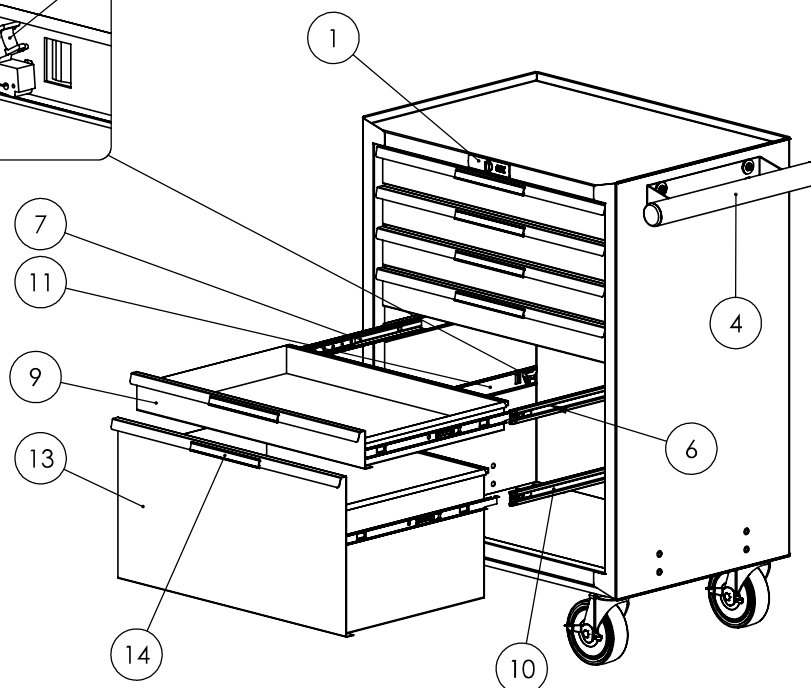
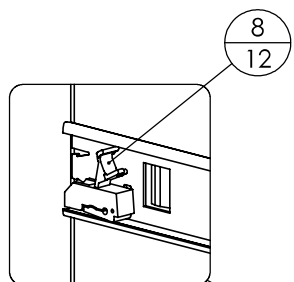
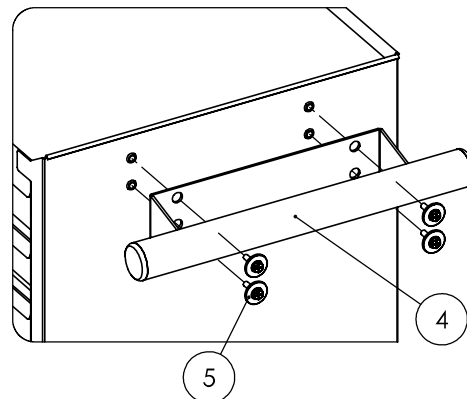
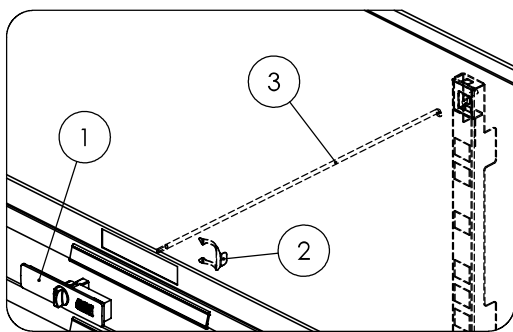

POS	DESCRIPTION	ITEM ID
1A	Combination lock 180°	TC-180CLOCK
1B	Key cylinder lock 180° (optional)	TC-180KEYLOCK
2	Cam for lock (included in Pos 1)	TCW806N-02
3	Locking bar	TCW603-01
4	Side handle	TCW807NBK1-14
5	Screws for side handle (4pcs)	TCW603-08
6	Slider 16" 36 mm Right (1pc)	TCW810N-05
7	Slider 16" 36 mm Left (1pc)	TCW810N-06
8	Clip for sliders (included in Pos 6 & 7)	TC803N-13
9	Drawer 575 x 380 x 75 mm Red	TSW26R-75
10	Slider 16" 51 mm Right (1pc)	TCW713-18
11	Slider 16" 51 mm Left (1pc)	TCW713-19
12	Clip for sliders (included in Pos 10 & 11)	TCW806LN-19
13	Drawer 575 x 380 x 312 mm Red with Logo	TSW26RF-300
14A	Aluminium drawer handle (3 pcs)	ALUE803
14B	Aluminium drawer handle (4 pcs)	ALUE804
15	Plastic spacer for casters 10 mm (1 pc)	TCW603-03
16	Screws for casters (4 pcs)	TCW603-09
17	Fixed casters 5" x 1-1/4" (1 pc)	TCW807N-13
18	Swivel casters 5" x 1-1/4" (1 pc)	TCW807N-12