

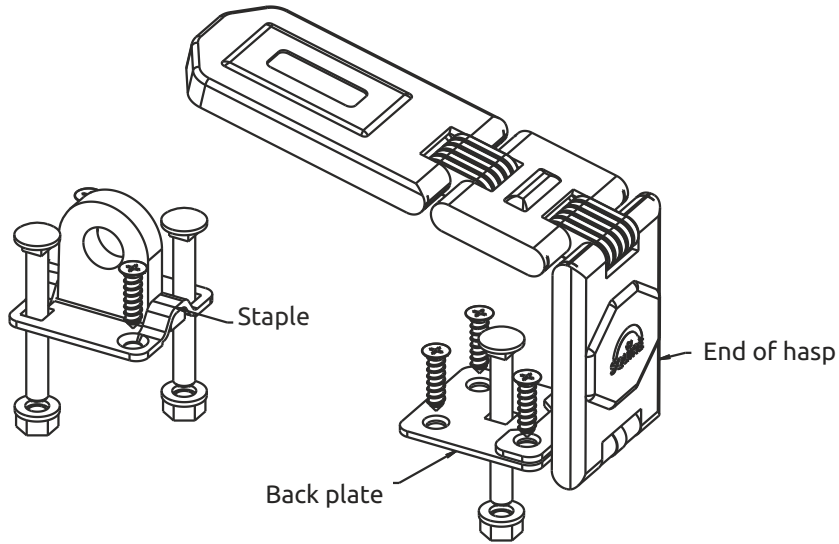

# DHH1 Fitting Instructions

FIG:1



## Fitting Instructions

1. Cut out the drilling template and attach to your door, make sure that the split line on the template lies on the middle of the gap between your door and frame.
2. Using a 3mm drill, make a hole to at least a depth of 20mm in the centre of each circle on the drilling template.
3. Using a 6.5mm drill, make a hole through the door in the centre of each square on the drilling template.
4. Remove the drilling template.
5. Line up the staple with the "S" side of the drilling template. Secure the staple with 2 screws and 2 bolts.
6. Orient the back plate in the same way shown in FIG:1. Line up the holes and secure the back plate with 4 screws and 1 bolt.
7. Fold the end of the hasp back over the back plate, the product is now ready to use.



## Drill Template

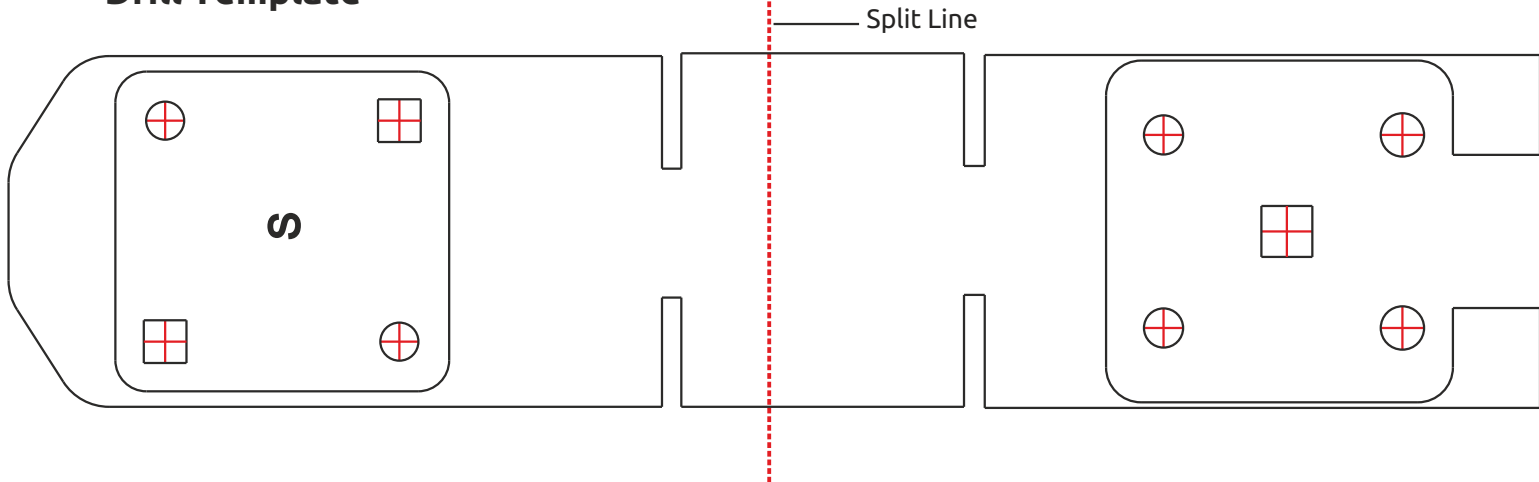

**Henry Squire & Sons Limited**

Hilton Cross Business Park, Cannock Road, Featherstone, Wolverhampton, WV10 7QZ

Tel: 01902 308050 Fax: 01902 308051 E-Mail: [info@henry-squire.co.uk](mailto:info@henry-squire.co.uk) Website: [www.squirelocks.co.uk](http://www.squirelocks.co.uk)