

# Network cable - VS-PPC/PL-IP20-93E-LI/5,0



1406030

<https://www.phoenixcontact.com/gb/products/1406030>

Please be informed that the data shown in this PDF document is generated from our Online Catalog. Please find the complete data in the user documentation. Our General Terms of Use for Downloads are valid.

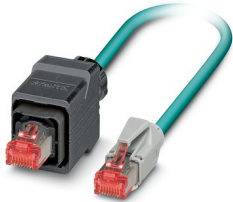

Assembled Ethernet cable, CAT5e, shielded, 2-pair, AWG 26 stranded (7-wire), RAL 5021 (water blue), RJ45 plug/IP67 push-pull plastic housing on RJ45 plug/IP20, line, length 5 m

## Commercial Data

Item number	1406030
Packing unit	1 pc
Minimum order quantity	1 pc
Note	Made to Order (non-returnable)
Sales Key	ABNEAI
Product Key	ABNEAI
Catalog Page	Page 399 (C-2-2019)
GTIN	4046356476027
Weight per Piece (including packing)	272.8 g
Weight per Piece (excluding packing)	272.8 g
Customs tariff number	85444210
Country of origin	PL

# Network cable - VS-PPC/PL-IP20-93E-LI/5,0



1406030

<https://www.phoenixcontact.com/gb/products/1406030>

## Technical Data

### Product properties

Product type	Data cable preassembled
Number of positions	4
No. of cable outlets	1
Number of slots	1
Shielded	yes
Cable outlet	straight

### Insulation characteristics

Degree of pollution	2
---------------------	---

### Electrical properties

Transmission medium	Copper
---------------------	--------

### Material specifications

Flammability rating according to UL 94	V2
--	----

### Connector

Insertion/withdrawal cycles	≥ 200
-----------------------------	-------

### Connection 1

Degree of protection	IP67
----------------------	------

### Cable / line

Cable length	5.00 m
Cable weight	43.00 kg/km
Cable type	Ethernet
External cable diameter	6.70 mm
Outer sheath, material	PUR
External sheath, color	water blue RAL 5021
Conductor material	Bare Cu litz wires
Conductor structure signal line	7x 0.16 mm
AWG signal line	26
Wire diameter incl. insulation	1 mm
Single wire, color	white-orange, white-green
Smallest bending radius, fixed installation	33.5 mm (cable, fixed installation)
Smallest bending radius, movable installation	33.5 mm (Cable, flexible installation)
Smallest bending radius, fixed installation	33.5 mm (cable, fixed installation)
Smallest bending radius, movable installation	33.5 mm (Cable, flexible installation)

### Ambient conditions

Degree of protection	IP20
	IP67

# Network cable - VS-PPC/PL-IP20-93E-LI/5,0



1406030

<https://www.phoenixcontact.com/gb/products/1406030>

---

Degree of protection	IP67/IP20
----------------------	-----------

---

# Network cable - VS-PPC/PL-IP20-93E-LI/5,0

1406030

<https://www.phoenixcontact.com/gb/products/1406030>

## Drawings

Dimensional drawing

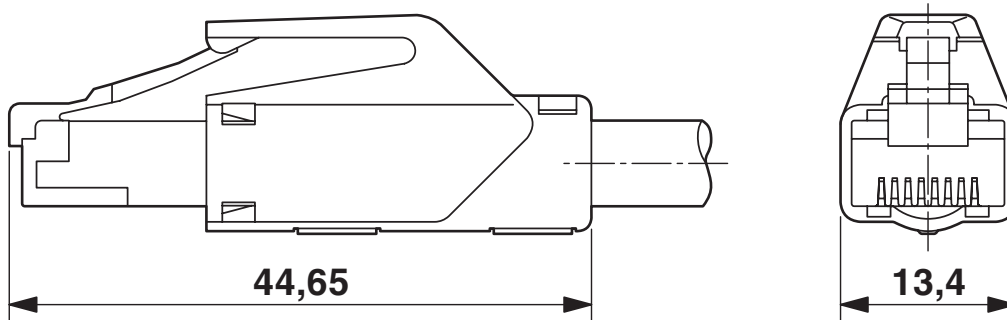

Circuit diagram

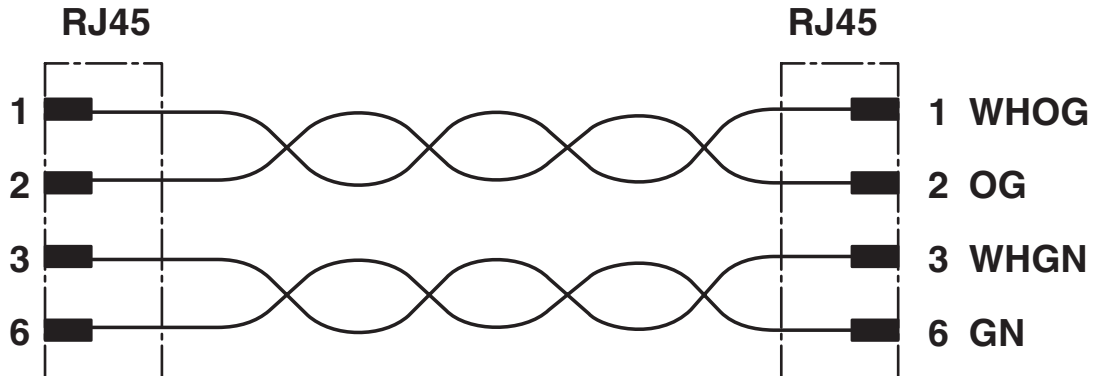

# Network cable - VS-PPC/PL-IP20-93E-LI/5,0

1406030

<https://www.phoenixcontact.com/gb/products/1406030>



Dimensional drawing

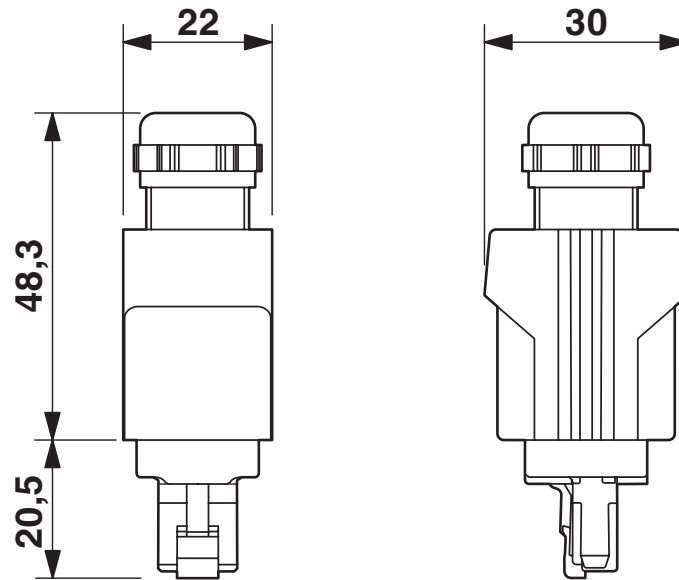

Push-pull RJ45 connector IP65/67

# Network cable - VS-PPC/PL-IP20-93E-LI/5,0



1406030

<https://www.phoenixcontact.com/gb/products/1406030>

## Approvals



**EAC**

Approval ID: 19060508

# Network cable - VS-PPC/PL-IP20-93E-LI/5,0



1406030

<https://www.phoenixcontact.com/gb/products/1406030>

## Classifications

### ECLASS

ECLASS-9.0	27060308
ECLASS-10.0.1	27060308
ECLASS-11.0	27060308

### ETIM

ETIM 8.0	EC002599
----------	----------

### UNSPSC

UNSPSC 21.0	26121600
-------------	----------

# Network cable - VS-PPC/PL-IP20-93E-LI/5,0



1406030

<https://www.phoenixcontact.com/gb/products/1406030>

## Environmental Product Compliance

China RoHS	Environmentally friendly use period: unlimited = EFUP-e
	No hazardous substances above threshold values

Phoenix Contact 2022 © - all rights reserved  
<https://www.phoenixcontact.com>

PHOENIX CONTACT Ltd  
Halesfield 13, Telford  
Shropshire, TF7 4PG  
01952 681700  
[info@phoenixcontact.co.uk](mailto:info@phoenixcontact.co.uk)