

## Unicase

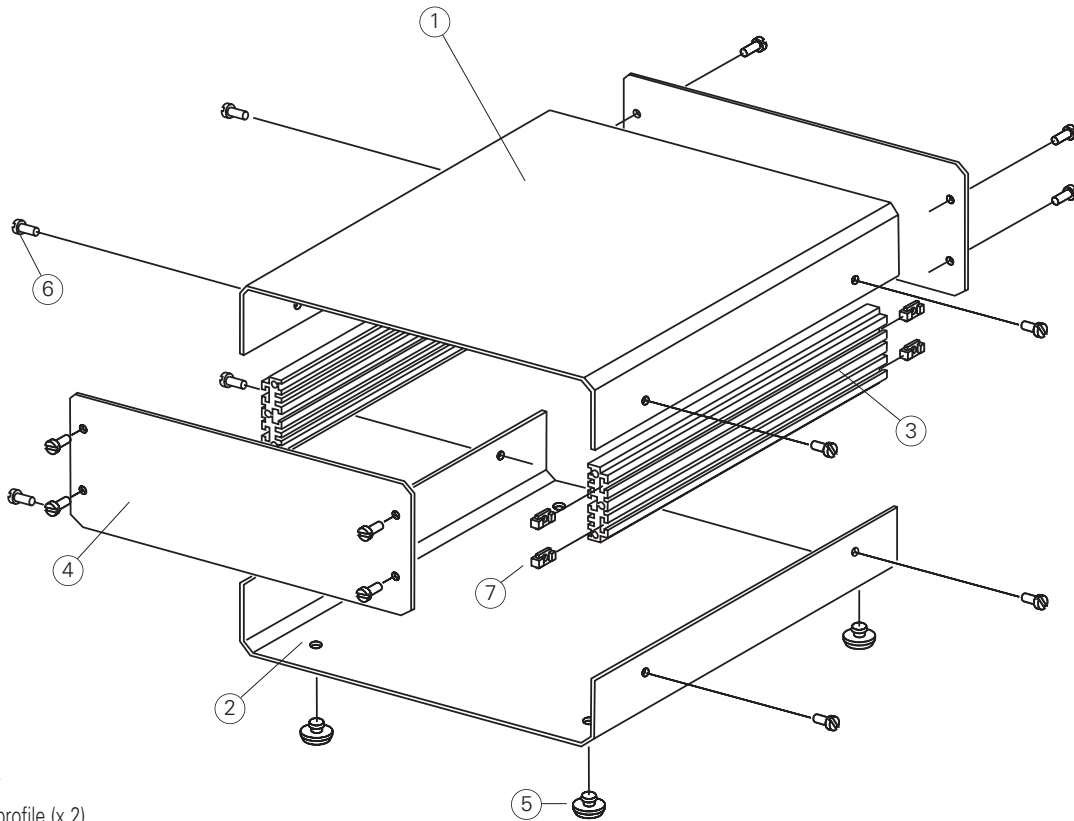

- ① Top cover
- ② Base cover
- ③ Assembly profile (x 2)
- ④ Front panel (x 2)
- ⑤ Rubber Foot (x 4)
- ⑥ M3 x 8 mm (x 16)
- ⑦ M3 captive nut (x 8)

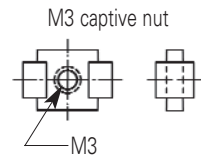

Part No.	Version	Part No.	Version
Bestell-Nr./Réf.		Bestell-Nr./Réf.	
<b>M 55 01 110</b>	Unicase 1	<b>M 55 11 110</b>	Unicase SL1
<b>M 55 02 110</b>	Unicase 2	<b>M 55 12 110</b>	Unicase SL2
<b>M 55 03 110</b>	Unicase 3	<b>M 55 13 110</b>	Unicase SL3
<b>M 55 04 110</b>	Unicase 4	<b>M 55 14 110</b>	Unicase SL4
<b>M 55 05 110</b>	Unicase 5		
<b>M 55 06 110</b>	Unicase 6		

## Assembly Procedure

## Assembly Procedure

1. Insert four rubber feet into case bottom.
2. Insert eight M3 captive nuts into the two assembly profiles.
3. Secure the two assembly profiles to the case bottom using four of the M3 x 6 screws (fastening to the captive nuts).
4. Secure the case top to the assembly profile as per step 3.
5. Secure the front panels using the remaining M3 x 6 screws (fastening to the front and rear of the assembly profiles).

The case is now ready for use.