



Contactor relay, 2N/O+2N/C, AC

Part no. DILER-22(110V50HZ,120V60HZ)
Catalog No. 051774
Eaton Catalog No. XTRM10A22A
EL-Nummer (Norway) 4110183

Delivery program

| | | | |
|---|----------------|---|---|
| Product range | | | DILER Mini-contactors |
| Application | | | Contactor relays |
| Description | | | with interlocked opposing contacts |
| Connection technique | | | Screw terminals |
| Rated operational current | | | |
| Conventional free air thermal current, 1 pole | | | |
| Open | | | |
| at 50 °C | $I_{th} = I_e$ | A | 10 |
| AC-15 | | | |
| 220 V 230 V 240 V | I_e | A | 6 |
| 380 V 400 V 415 V | I_e | A | 3 |
| Contacts | | | |
| N/O = Normally open | | | 2 N/O |
| N/C = Normally closed | | | 2 NC |
| Contact sequence | | | |
| Code number and version of combination | | | |
| Distinctive number | | | 22E |
| For use with | | | ...DILE |
| Actuating voltage | | | 110 V 50 Hz, 120 V 60 Hz |
| Voltage AC/DC | | | AC operation |
| Instructions | | | Contact numbers to EN 50011 Coil terminal markings to EN 50005 |

Technical data

| | | | |
|-----------------------------|--------------|---------------|--|
| General | | | |
| Standards | | | IEC/EN 60947, EN 60947-5-1, VDE 0660, UL, CSA |
| Lifespan, mechanical | | | |
| AC operated | Operations | $\times 10^6$ | 10 |
| Maximum operating frequency | Operations/h | | 9000 |
| Climatic proofing | | | Damp heat, constant, to IEC 60068-2-78 Damp heat, cyclic, to IEC 60068-2-30 |
| Ambient temperature | | | |
| Open | | °C | -25 - +50 |
| Enclosed | | °C | - 25 - 40 |
| Mounting position | | | |
| Mounting position | | | As required, except vertical with terminals A1/A2 at the bottom |
| Mounting position | | | |

| | | | |
|---|-----------------|---|-------------------------------|
| Mechanical shock resistance (IEC/EN 60068-2-27) | | | |
| Half-sinusoidal shock, 10 ms | | | |
| Basic unit with auxiliary contact module | g | | |
| N/O contact | g | 10 | |
| N/C contact | g | 8 | |
| Degree of Protection | | | IP20 |
| Protection against direct contact when actuated from front (EN 50274) | | | Finger and back-of-hand proof |
| Weight | | | |
| AC operated | kg | 0.17 | |
| Terminal capacities | | | |
| Screw terminals | | | |
| Solid | mm ² | 1 x (0.75 - 2.5) 2 x (0.75 - 2.5) | |
| Flexible with ferrule | mm ² | 1 x (0.75 - 1.5) 2 x (0.75 - 1.5) | |
| Solid or stranded | AWG | 18 - 14 1 x (18 - 14) 2 x (18 - 14) | |
| Stripping length | mm | 8 | |
| Terminal screw | | M3.5 | |
| Pozidriv screwdriver | Size | 2 | |
| Standard screwdriver | mm | 0.8 x 5.5 1 x 6 | |
| Max. tightening torque | Nm | 1.2 | |

Contacts

| | | | |
|---|----------------|-----------|--|
| Interlocked opposing contacts to ZH 1/457, including auxiliary contact module | | | Yes |
| Rated impulse withstand voltage | U_{imp} | V AC | 6000 |
| Overvoltage category/pollution degree | | | III/3 |
| Rated insulation voltage | U_i | V AC | 690 |
| Rated operational voltage | U_e | V AC | 600 |
| Safe isolation to EN 61140 | | | |
| between coil and auxiliary contacts | | V AC | 300 |
| between the auxiliary contacts | | V AC | 300 |
| Rated operational current | | | |
| Conventional free air thermal current, 1 pole | | | |
| Open | | | |
| at 50 °C | $I_{th} = I_e$ | A | 10 |
| AC-15 | | | |
| 220 V 230 V 240 V | I_e | A | 6 |
| 380 V 400 V 415 V | I_e | A | 3 |
| 500 V | I_e | A | 1.5 |
| DC current | | | |
| Notes | | | Switch-on and switch-off conditions based on DC-13, time constant as specified. |
| DC L/R \leq 15 ms | | | |
| Contacts in series: | | A | |
| 1 | 24 V | A | 2.5 |
| 2 | 60 V | A | 2.5 |
| 3 | 110 V | A | 1.5 |
| 3 | 220 V | A | 0.5 |
| Control circuit reliability | Failure rate | λ | $<10^{-8}$, < one failure at 100 million operations (at $U_e = 24$ V DC, $U_{min} = 17$ V, $I_{min} = 5.4$ mA) |
| Short-circuit rating without welding | | | |
| Maximum overcurrent protective device | | | |
| 220 V 230 V 240 V | | PKZM0 | 4 |
| 380 V 400 V 415 V | | PKZM0 | 4 |
| Short-circuit protection maximum fuse | | | |
| 500 V | | A gG/gL | 6 |

| | | | |
|-------------------------------|--|--------|-----|
| 500 V | | A fast | 10 |
| Current heat loss at I_{th} | | | |
| AC operated | | W | 1.1 |

Magnet systems

| | | | |
|--|---------|---------|---------|
| Voltage tolerance | | | |
| AC operated | | | |
| Single-voltage coil 50 Hz and dual-voltage coil 50 Hz, 60 Hz | Pick-up | $x U_c$ | |
| Voltage tolerance Single-voltage coil 50 Hz and dual-voltage coil 50 Hz, 60 Hz Pick-up voltage, min. | | $x U_c$ | 0.8 |
| Voltage tolerance Single-voltage coil 50 Hz and dual-voltage coil 50 Hz, 60 Hz Pick-up voltage, max. | | $x U_c$ | 1.1 |
| Dual-frequency coil 50/60 Hz | Pick-up | $x U_c$ | |
| Voltage tolerance Dual-frequency coil 50/60 Hz Pick-up voltage, min. | | $x U_c$ | 0.85 |
| Voltage tolerance Dual-frequency coil 50/60 Hz, max. pick-up voltage | | $x U_c$ | 1.1 |
| Power consumption | | | |
| AC operation | | | |
| Single-voltage coil 50 Hz and dual-voltage coil 50 Hz, 60 Hz | Pick-up | VA | 25 |
| Single-voltage coil 50 Hz and dual-voltage coil 50 Hz, 60 Hz | Sealing | VA | 4.6 |
| Single-voltage coil 50 Hz and dual-voltage coil 50 Hz, 60 Hz | Sealing | W | 1.3 |
| duty factor | | % DF | 100 |
| Changeover time at 100 % U_S (recommended value) | | | |
| AC operated closing delay | | ms | 14 - 21 |
| AC operated N/O contact opening delay | | ms | 8 - 18 |
| AC operated With auxiliary contact module Max. closing delay | | ms | 45 |

Rating data for approved types

| | | | |
|--------------------|--|---|------|
| Auxiliary contacts | | | |
| Pilot Duty | | | |
| AC operated | | | A600 |
| DC operated | | | P300 |
| General Use | | | |
| AC | | V | 600 |
| AC | | A | 10 |
| DC | | V | 250 |
| DC | | A | 0.5 |

Design verification as per IEC/EN 61439

| | | | |
|--|------------|----|--|
| Technical data for design verification | | | |
| Rated operational current for specified heat dissipation | I_n | A | 6 |
| Heat dissipation per pole, current-dependent | P_{vid} | W | 0.4 |
| Equipment heat dissipation, current-dependent | P_{vid} | W | 0 |
| Static heat dissipation, non-current-dependent | P_{vs} | W | 1.8 |
| Heat dissipation capacity | P_{diss} | W | 0 |
| Operating ambient temperature max. | | °C | -25 |
| Operating ambient temperature max. | | °C | 50 |
| IEC/EN 61439 design verification | | | |
| 10.2 Strength of materials and parts | | | |
| 10.2.2 Corrosion resistance | | | Meets the product standard's requirements. |
| 10.2.3.1 Verification of thermal stability of enclosures | | | Meets the product standard's requirements. |
| 10.2.3.2 Verification of resistance of insulating materials to normal heat | | | Meets the product standard's requirements. |
| 10.2.3.3 Verification of resistance of insulating materials to abnormal heat and fire due to internal electric effects | | | Meets the product standard's requirements. |
| 10.2.4 Resistance to ultra-violet (UV) radiation | | | Meets the product standard's requirements. |
| 10.2.5 Lifting | | | Does not apply, since the entire switchgear needs to be evaluated. |
| 10.2.6 Mechanical impact | | | Does not apply, since the entire switchgear needs to be evaluated. |
| 10.2.7 Inscriptions | | | Meets the product standard's requirements. |
| 10.3 Degree of protection of ASSEMBLIES | | | Does not apply, since the entire switchgear needs to be evaluated. |

| | | |
|--|--|--|
| 10.4 Clearances and creepage distances | | Meets the product standard's requirements. |
| 10.5 Protection against electric shock | | Does not apply, since the entire switchgear needs to be evaluated. |
| 10.6 Incorporation of switching devices and components | | Does not apply, since the entire switchgear needs to be evaluated. |
| 10.7 Internal electrical circuits and connections | | Is the panel builder's responsibility. |
| 10.8 Connections for external conductors | | Is the panel builder's responsibility. |
| 10.9 Insulation properties | | |
| 10.9.2 Power-frequency electric strength | | Is the panel builder's responsibility. |
| 10.9.3 Impulse withstand voltage | | Is the panel builder's responsibility. |
| 10.9.4 Testing of enclosures made of insulating material | | Is the panel builder's responsibility. |
| 10.10 Temperature rise | | The panel builder is responsible for the temperature rise calculation. Eaton will provide heat dissipation data for the devices. |
| 10.11 Short-circuit rating | | Is the panel builder's responsibility. The specifications for the switchgear must be observed. |
| 10.12 Electromagnetic compatibility | | Is the panel builder's responsibility. The specifications for the switchgear must be observed. |
| 10.13 Mechanical function | | The device meets the requirements, provided the information in the instruction leaflet (IL) is observed. |

Technical data ETIM 6.0

| | | |
|--|---|------------------|
| Low-voltage industrial components (EG000017) / Contactor relay (EC000196) | | |
| Electric engineering, automation, process control engineering / Low-voltage switch technology / Contactor (LV) / Contactor relay (ec @ss8.1-27-37-10-01 [AAB716011]) | | |
| Rated control supply voltage U_s at AC 50HZ | V | 110 - 110 |
| Rated control supply voltage U_s at AC 60HZ | V | 120 - 120 |
| Rated control supply voltage U_s at DC | V | 0 - 0 |
| Voltage type for actuating | | AC |
| Rated operation current I_e , 400 V | A | 3 |
| Connection type auxiliary circuit | | Screw connection |
| Mounting method | | DIN-rail/screw |
| Interface | | No |
| Number of auxiliary contacts as normally closed contact | | 2 |
| Number of auxiliary contacts as normally open contact | | 2 |
| Number of auxiliary contacts as normally closed contact, delayed switching | | 0 |
| Number of auxiliary contacts as normally open contact, leading | | 0 |
| With LED indication | | No |
| Number of auxiliary contacts as change-over contact | | 0 |
| Manual operation possible | | No |

Approvals

| | | |
|--------------------------------------|--|---|
| Product Standards | | IEC/EN 60947-4-1; UL 508; CSA-C22.2 No. 14-05; CE marking |
| UL File No. | | E29184 |
| UL Category Control No. | | NKCR |
| CSA File No. | | 012528 |
| CSA Class No. | | 3211-03 |
| North America Certification | | UL listed, CSA certified |
| Specially designed for North America | | No |

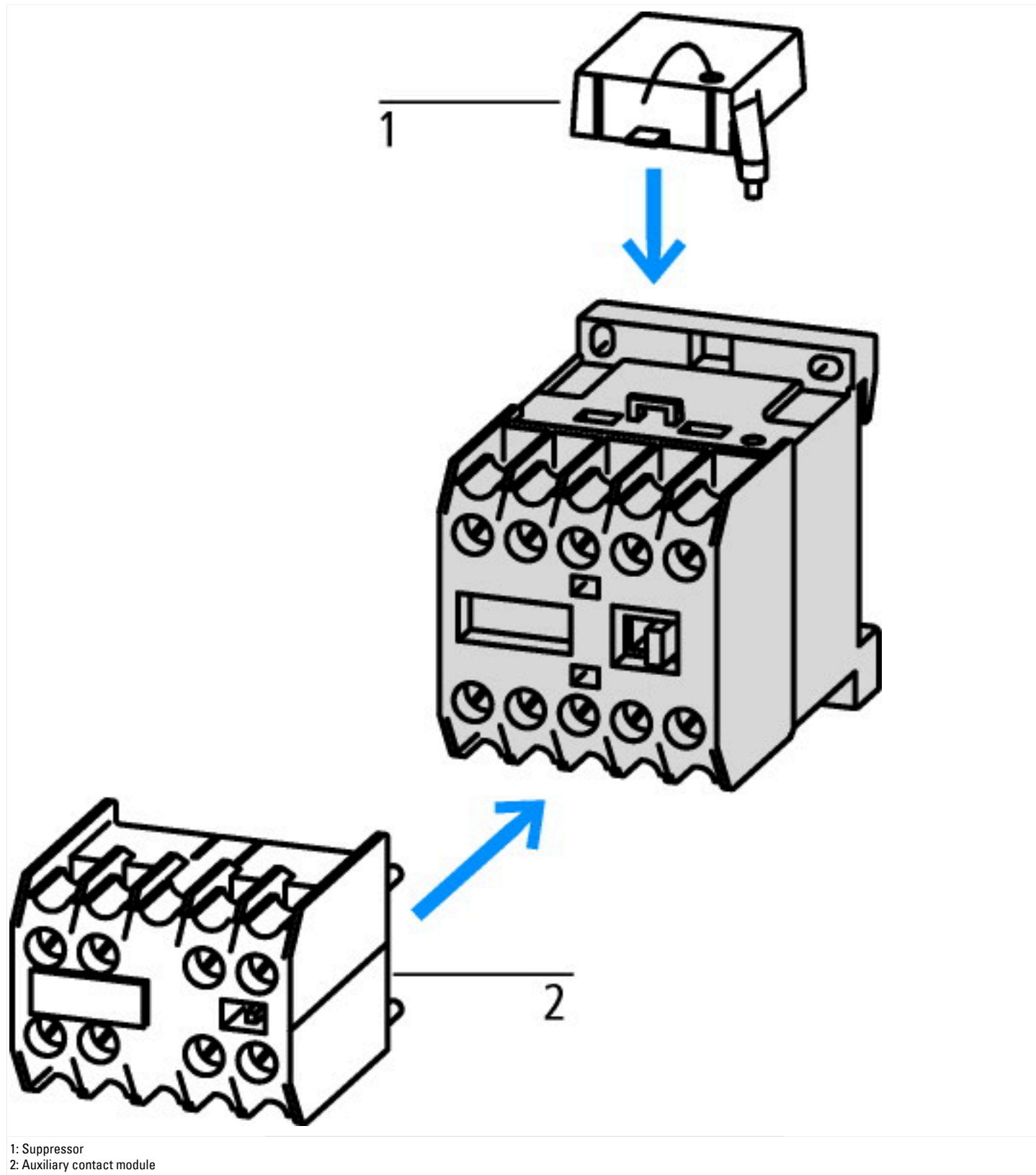



Component lifespan (operations)
 I_e = Rated operational current

Dimensions



DILER...
 DILER...-G(-C)



DILER-...(-C) + ...DILE(-C)
 DILER-...-G(-C) + ...DILE(-C)

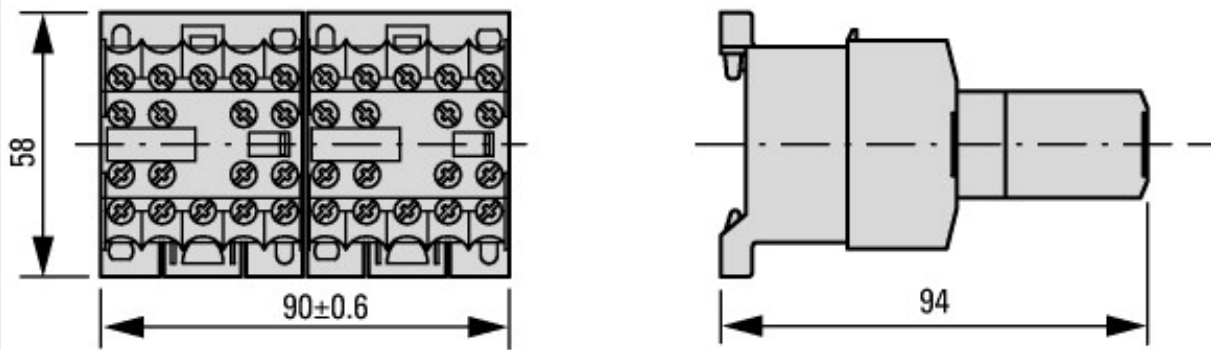

2DILE-... + MVDILE + ...DILE
 2DILE-...-G + MVDILE + ...DILE

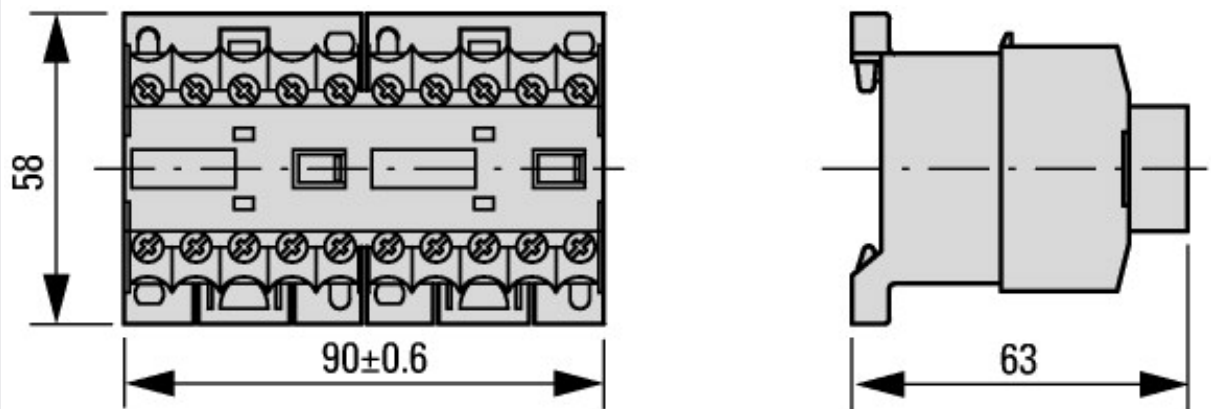

2DILE-... + MVDILE
 2DILE-...-G + MVDILE

Assets (Links)

Declaration of Conformity

00002475

Instruction Leaflets

IL03407009Z2016_03

Additional product information (links)

IL03407009Z (AWA2100-0882) Mini contactor relay

IL03407009Z (AWA2100-0882) Mini contactor relay

ftp://ftp.moeller.net/DOCUMENTATION/AWA_INSTRUCTIONS/IL03407009Z2016_03.pdf

UL/CSA: Approved rating data

<http://de.ecat.moeller.net/flip-cat/?edition=HPLTE&startpage=5.84>