

Figure 1

94-66

1. INTRODUCTION

This instruction sheet covers operation and maintenance of AMP MTA Terminating Head 58247-1 for use in AMP Pistol Grip Manual Handle Assembly 58074-1, or AMP Pistol Grip Pneumatic Handle Assembly 58075-1. Read these instructions thoroughly before using the heads. Refer to the instructions packaged with the pistol grip handle assembly for head installation and removal: 408-6790 (manual) and 408-6789 (pneumatic).

NOTE

All dimensions on this document are in metric units [with U.S. customary units in brackets].

See Section 8, REVISION SUMMARY, for revision information.

2. DESCRIPTION

This head is used to terminate unstripped wires in several types of MTA-156 closed-end receptacle assemblies: connectors with or without lock (ramp) and with or without polarizing tabs, and quad connectors with or without polarizing tabs. Slotted contacts for insulation displacement termination are pre-assembled on 3.96 [.156 in.] centerlines in each color-coded housing for a specific wire range. Refer to Figure 2 and to Application Specification 114-1020 for further details.

The head, which is inserted into the pistol grip handle assembly, serves as a guide and support for the connector during termination. Features of the head (shown in Figure 1) and their functions are as follows:

- Wire Inserter* – forces wire into the two slotted beams of the contact. Note that it provides support for the contact beams when applying insertion force on the wire.
- Adjuster (Insertion Rod)* – is a piston for the wire inserter and regulates wire inserter travel.
- Feed Slide* – automatically positions the connector after each termination.
- Locating Pawl* – aligns connector for insertion, and retains it during termination. The locating pawl is sometimes referred to as the “anti-backup pawl.”

3. SETUP ADJUSTMENTS AND TEST

The adjuster (insertion rod) of the wire inserter is preset for wire sizes 18 through 26 AWG. If the wire is being inserted too deeply or not deeply enough inside the contact, it may be necessary to adjust the depth of the wire inserter; or, if the pneumatic handle assembly is being used, it may be necessary to adjust either the air pressure or the depth of the wire inserter.

3.1. For Pistol Grip Manual Handle Assembly

1. Determine the wire size, and select the appropriate color-coded connector from the chart in Figure 2. Dash numbers are used to indicate number of contact positions.
2. Using a small knife, cut off the wire retainers (strain relief). This will provide a clear view for inspecting the connector for a properly terminated wire in the contact. See Figure 3.

WIRE SIZE (AWG)	MTA-156 IDC RECEPTACLE CONNECTORS						MTA-156 QUAD CONNECTORS BLACK, with LOCK	
	COLOR CODE	WITH LOCK		WITHOUT LOCK		WITHOUT PLZ TABS	WITH PLZ TABS	
		WITHOUT PLZ TABS	WITH PLZ TABS	WITHOUT PLZ TABS	WITH PLZ TABS			
18	ORANGE	640426 641217	643817 644460	640431 641222 644502	644082 644461	644329	644381	
20	YELLOW	640427 641218	643818 644663	640432 641223	644462	644370	644382	
22	RED	640428 641219	643819 644662	640433 641224 644501	644463 644566 644687	644371	644383	
24	NATURAL	640429	643820	640434 644503	644464	—	—	
26	BLUE	640430	—	640435	—	—	—	

Figure 2

CAUTION Wire retainers are removed to provide a connector for testing only. Do NOT use such connectors for production applications.

If you determine that the wire insertion depth is incorrect, proceed to Paragraph 3.3, Wire Insertion Depth Adjustment.

- Place connector in tool and make a test termination using procedure described in Section 4, TERMINATING PROCEDURE, Steps 1 through 6.
- Push connector out of right side of head.
- Inspect termination in accordance with Section 5, INSPECTION, Steps 1 through 6.

3.2. For Pistol Grip Pneumatic Handle Assembly

- Perform the procedure outlined in Paragraph 3.1, For Pistol Grip Manual Handle Assembly, Steps 1 through 4.
- Inspect termination to ensure that conductor is terminated past the lead-in transition and is positioned about halfway into the contact slot. See Figure 3.

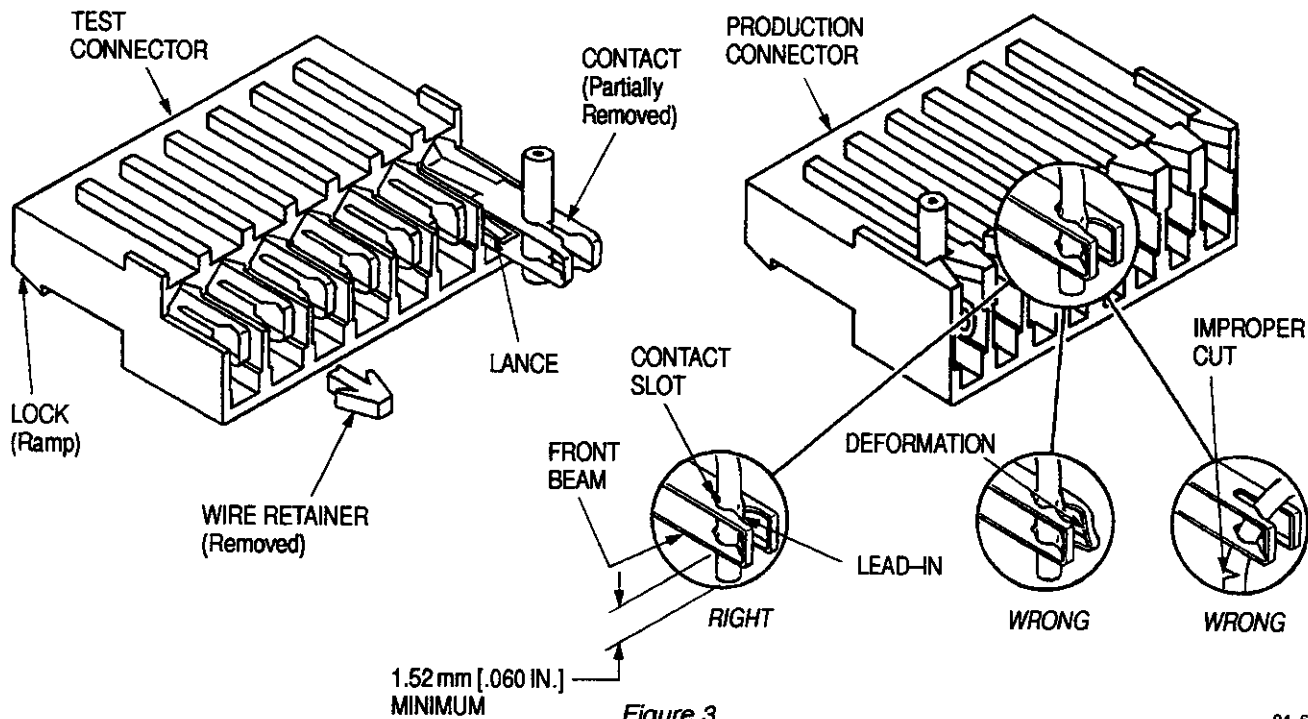
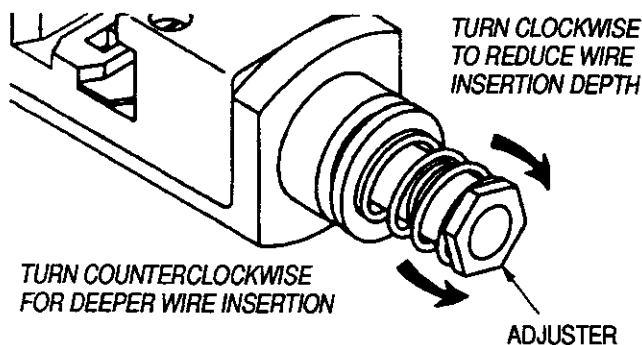

Figure 3



TURN COUNTERCLOCKWISE
FOR DEEPER WIRE
INSERTION

TURN CLOCKWISE
TO REDUCE WIRE
INSERTION DEPTH

ADJUSTER

NOTE: 1/6 TURN EQUALS .203 mm [.008 IN.] ADJUSTMENT.

Figure 4

31-11

3. Inspect termination to ensure that insulation is 1.52 [.060 in.] minimum beyond the front contact beam.
4. If, upon inspection, it is determined that the wire is not inserted deeply enough, increase the air pressure by 69 kPa [10 psi], and repeat the termination and inspection procedure. Continue in this manner until either the proper insertion depth is obtained or the air pressure is set to 483 kPa [70 psi]. If the proper insertion depth is NOT reached at 483 kPa [70 psi], return the air pressure to 276 kPa [40 psi] and follow the procedure in Paragraph 3.3, Wire Insertion Depth Adjustment.
5. If the wire is inserted too deeply, refer to the procedure in Paragraph 3.3, Wire Insertion Depth Adjustment.

3.3. Wire Insertion Depth Adjustment

Wire Too Deep in Wire Contact Slot – If the wire is inserted too deeply, remove the head, and turn the adjuster 1/6 revolution **CLOCKWISE** (see Figure 4). This will reduce the wire insertion depth by approximately .203 mm [.008 in.]. Repeat Steps 3, 4, and 5 of Paragraph 3.1, for Pistol Grip Manual Handle Assembly.

Wire Not Deep Enough in Contact Slot – If the wire is NOT inserted deeply enough in contact slot, remove the head and turn the adjuster 1/6 revolution **COUNTERCLOCKWISE** (see Figure 4). This will increase the wire insertion depth by approximately .203 mm [.008 in.]. Repeat Steps 3, 4, and 5 of Paragraph 3.1 (or Steps 3 and 4 of Paragraph 3.2).

4. TERMINATING PROCEDURE (Figure 5)

1. Insert connector into left side of head as indicated.
2. Align contact to be terminated with wire inserter.
3. Make sure locating pawl rests between connector index ribs.
4. Insert an unstripped wire into the funnel area between contact and wire inserter until it bottoms on tool base.
5. Depress trigger (or squeeze cam handle) of pistol grip handle assembly and hold it until inserter bottoms or ratchet releases.
6. Release trigger (or cam handle). The inserter will retract and the feed slide will automatically advance connector to next contact position.

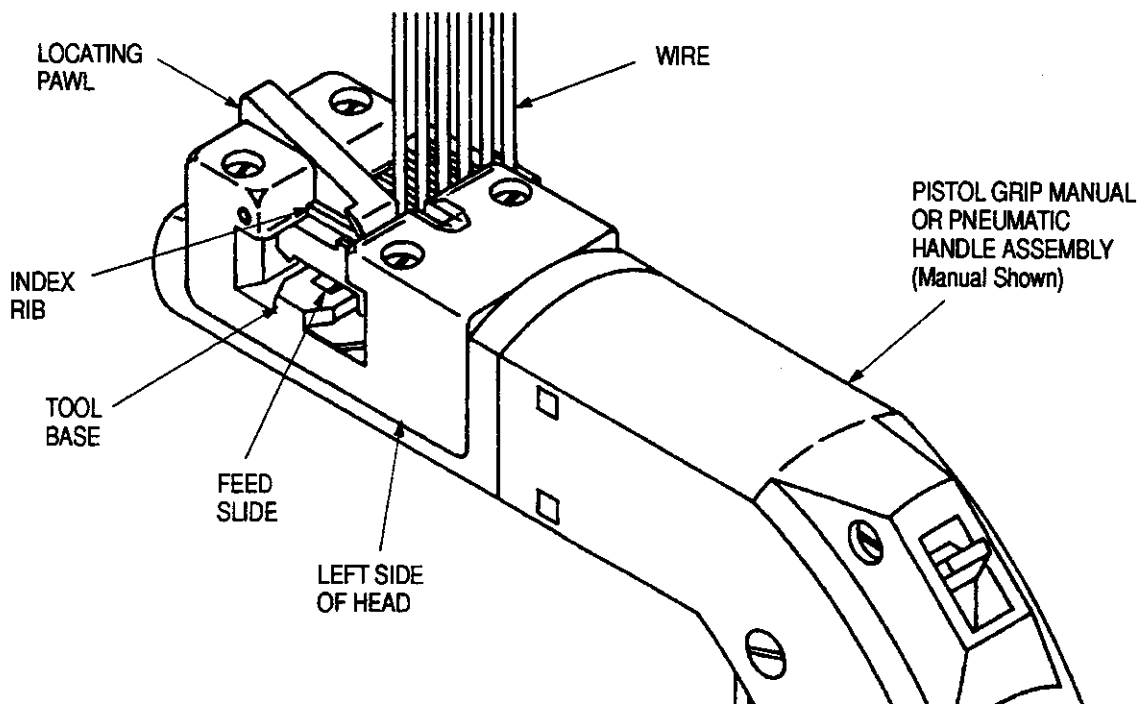

Figure 5

31-10

NOTE

The locating pawl will move up and down as the connector is automatically advanced through the head. However, if movement is obstructed, or if desirable, the locating pawl can be depressed and the connector moved manually out the RIGHT side of the head.

7. Repeat Steps 2 through 6 until all contacts have been terminated.
8. Inspect each termination according to the procedure in Section 5, INSPECTION.

5. INSPECTION (Figure 3)

Inspect each termination to ensure the following:

1. Conductor is terminated past the lead-in transition and about halfway in the contact slot.
2. Insulation is 1.52 [.060 in.] minimum beyond the front contact beam. See Figure 3.
3. Wire is NOT bottomed in contact slot.
4. Contact beams are NOT deformed. If damage is apparent, replace contacts in accordance with the instructions packaged with the connector.
5. Insulation of wire is NOT nicked or cut in any area other than the two wire slots.
6. Wire extends below the strain-relief features of connector.

6. TOOL MAINTENANCE

The procedures described in the following text have been established to assure quality and reliability of AMP terminating tools. A brief check should be made daily, and a more detailed inspection should be scheduled by your quality control group.

6.1. Daily Maintenance

Each operator should be aware of, and responsible for, the following:

1. Remove dust, moisture, and other contaminants with a clean brush, or soft, lint-free cloth. Do NOT use objects that could damage the tool.
2. Make sure all components are in place and properly secured. If NOT, return the tool to your supervisor.
3. Actuate handle assembly to ensure mechanisms inside head move smoothly.

6.2. Periodic Maintenance

Regular inspections should be performed by your quality control personnel with a record of these control inspections remaining with the personnel responsible for the tool. We recommend one inspection a month; however, operator training and skill, amount of use, ambient working conditions, and your company's established standards are all factors in establishing frequency of inspections.

These inspections should be done in the following sequence:

1. Remove any accumulated film with a suitable cleaning agent that will NOT affect plastic material.
2. Make sure all components are in place and properly secured. See Figure 6.
3. Make a few test terminations and inspect the terminations in accordance with Section 5, INSPECTION.
4. Check for chipped, cracked, worn, or broken areas. If damage is evident, repair is necessary. See Section 7, REPLACEMENT AND REPAIR.

7. REPLACEMENT AND REPAIR

The parts listed in Figure 6 are customer-replaceable. A complete inventory can be stocked and controlled to prevent lost time when replacement of parts is necessary. Order replacement parts through your AMP representative, or call 1-800-526-5142, or send a facsimile of your purchase order to 1-717-986-7605. or write to:

CUSTOMER SERVICE (38-35)
AMP INCORPORATED
P. O. BOX 3608
HARRISBURG, PA 17105-3608

Tools may be returned to AMP for evaluation and repair. For repairs, send tool, with a written description of the problem to:

CUSTOMER REPAIR (01-12)
AMP INCORPORATED
1523 NORTH 4TH STREET
HARRISBURG, PA 17102-1604

8. REVISION SUMMARY

Since the previous release of this sheet, the following changes were made:

Per EC 0990-0252-93:

- Corrected minimum dimension to 1.52 mm [.060 IN.] in Figure 3

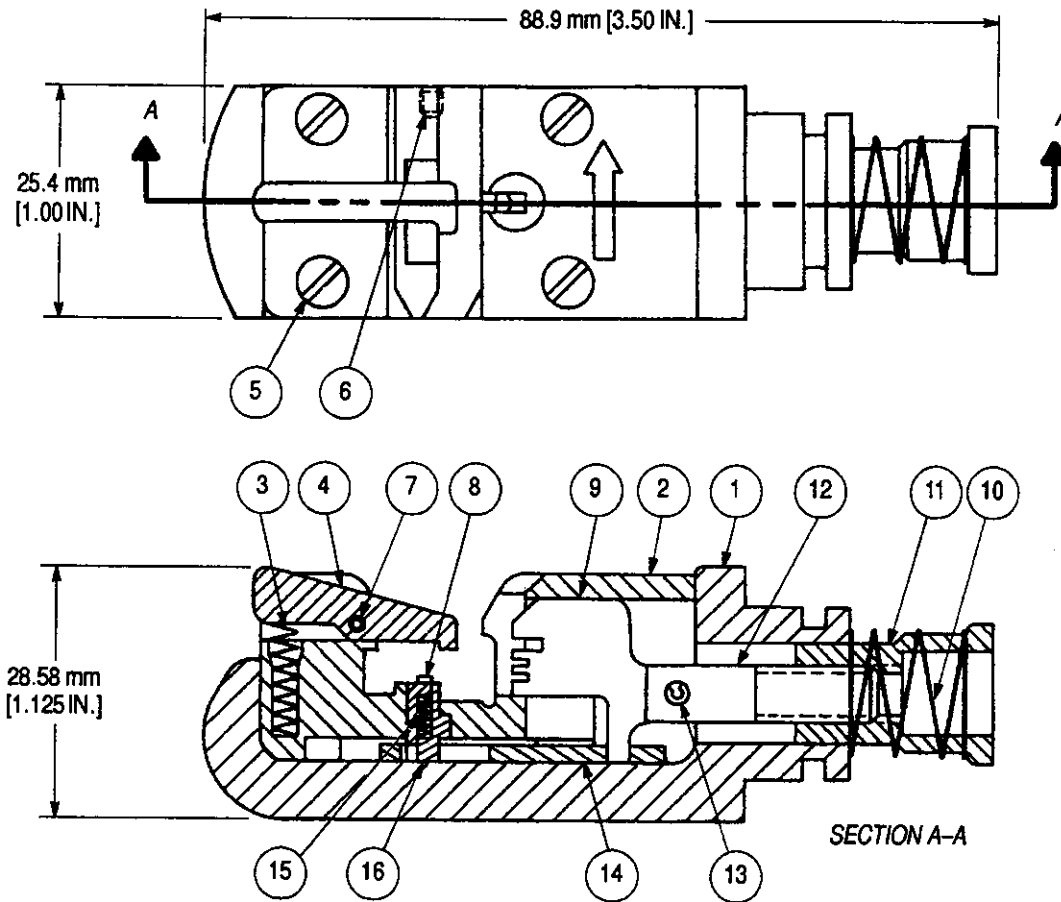

WEIGHT: 85 g [3 oz.]

CUSTOMER REPLACEABLE PARTS

ITEM	PART NUMBER	DESCRIPTION	QTY
1	312150-1	HEAD, Finished	1
2	312138-3	HOUSING, Insert	1
3	6-22278-5	SPRING, Compression	1
4	312147-1	PAWL, Locating	1
5	4-22430-8	SCREW, Mach (4-40 x .875 L)	4
6	1-21010-9	SETSCREW, Skt (4-40 x .125 L)	1
7	21041-7	PIN, Spiral Spring	1
8	312192-1	PAWL, Feed	1
9	312154-1	INSERTER, Wire	1
10	22488-5	SPRING, Compression	1
11	312149-1	ADJUSTER, Rod Insertion	1
12	312148-1	ROD, Inserter	1
13	3-21028-2	PIN, Slotted Spring	1
14	312153-1	CAM, Traverse Slide	1
15	1-23147-2	SPRING, Compression	1
16	312151-1	SLIDE, Feed	1

Figure 6

31-12