

TRUCHECK™ 2 & TRUCHECK™ 2 PLUS



CONTENTS

Part Numbers Covered by This Manual	2
Set Up Instructions	2
TruCheck™ 2 (0.1 – 30 N·m)	2
TruCheck™ 2 (3 – 2,100 N·m)	2
Operating Instructions – TruCheck™ 2 Plus	3
Measurement Screen	3
Units Menu	4
Click Menu	4
Target Menu	4
Version Screen	5
Set Up Menu	5
Zero Resetting	5
Active From Setting	5
Target Indication	6
Using the Instrument	7
USB Port	7
Operating Instructions – TruCheck™ 2 Basic	8
Measurement Screen	8
Using the Instrument	8
Version Screen	8
Set Up Menu	9
Track Mode	9
Zero Resetting	9
Calibrate Mode	9
USB Port	9
Specifications	10
TruCheck™ 2 (0.1 – 30 N·m)	10
TruCheck™ 2 (3 – 2,100 N·m)	11
Calibration	13
Repair	13
Cleaning	13
Warning	13
Disposal	13

PART NUMBERS COVERED BY THIS MANUAL

This manual covers the set up and use of Norbar TruCheck™ 2 and TruCheck™ 2 Plus instruments.

Part Number	Model	Part Number	Model
43514	TruCheck™ 2 3 N·m	43523	TruCheck™ 2 Plus 260 lbf·ft
43515	TruCheck™ 2 Plus 3 N·m	43524	TruCheck™ 2 350 N·m
43516	TruCheck™ 2 10 N·m	43525	TruCheck™ 2 Plus 350 N·m
43517	TruCheck™ 2 Plus 10 N·m	43528	TruCheck™ 2 800 lbf·ft
43518	TruCheck™ 2 30 N·m	43529	TruCheck™ 2 Plus 800 lbf·ft
43519	TruCheck™ 2 Plus 30 N·m	43530	TruCheck™ 2 1,100 N·m
43520	TruCheck™ 2 65 N·m	43531	TruCheck™ 2 Plus 1,100 N·m
43521	TruCheck™ 2 Plus 65 N·m	43532	TruCheck™ 2 2,100 N·m
43522	TruCheck™ 2 260 lbf·ft	43533	TruCheck™ 2 Plus 2,100 N·m

SET UP INSTRUCTIONS

TruCheck™ 2 (0.1 – 30 N·m)

1. Identify a suitable surface and position to mount the instrument.
2. Drill two mounting holes suitable for M6 fasteners (M6 Cap Screws of grade 8.8 minimum are recommended).
3. Recommended fastener torque of 7.3 to 8.4 N·m (5.4 to 6.2 lbf·ft).
4. After connecting the provided power supply the instrument will be ready to use after approximately 12 seconds.

TruCheck™ 2 (3 – 2,100 N·m)

1. Identify a suitable surface and position to mount the instrument.
2. Drill two mounting holes suitable for M10 fasteners (M10 Cap Screws of grade 12.9 minimum are recommended).
3. Recommended fastener torque of 35 to 40 N·m (25 to 30 lbf·ft).
4. After connecting the provided power supply the instrument will be ready to use after approximately 12 seconds.



WARNING: ENSURE THE MOUNTING SURFACE IS CAPABLE OF SUPPORTING THE INSTRUMENT WHEN THE RATED CAPACITY TORQUE IS APPLIED.

ONLY USE THE POWER SUPPLY PROVIDED.

DO NOT APPLY TORQUE ABOVE THE RATED CAPACITY.

TruCheck™ 2 is intended for testing torque tools only.

OPERATING INSTRUCTIONS – TRUCHECK™ 2 PLUS

(43515, 43517, 43519, 43521, 43523, 43525, 43529, 43531 & 43533)

Measurement Screen

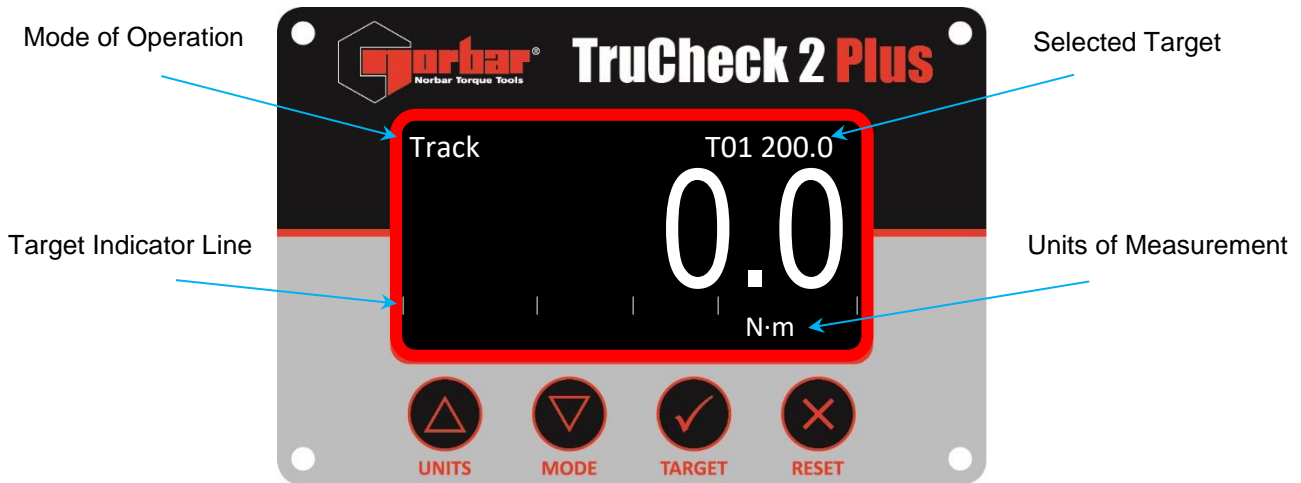

Changes the Units of Measurement
(N·m, lbf·ft and lbf·in etc.)

To enable/disable units, use the UNITS MENU (Press and Hold)



Changes the Selected Target
(T01 XXX.X, T02 XXX.X etc.)
Units are automatically changed to the targets units.

NOTE: T-- ---- means Targets are OFF

To edit targets, use the TARGET MENU (Press and Hold)



Changes the Mode of Operation
(Track, Click and Dial)

To change Click Mode settings, use the CLICK MENU (Press and Hold)







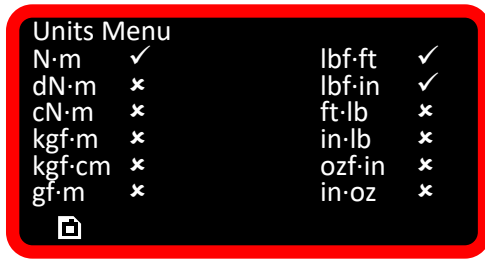

Resets a captured peak
In Dial Mode (and Click Mode if set to Manual Reset)

Zeroes the reading
In Track Mode if reading <4% Full Scale Deflection (FSD)
In Click and Dial Mode if reading <1% FSD

Units Menu









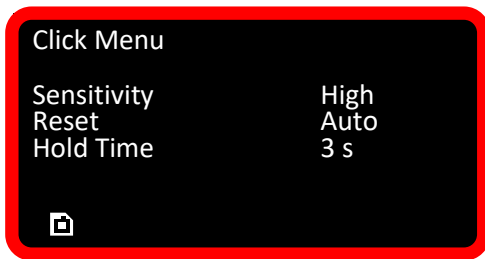

-   Select units to enable/disable
-  Toggle enable/disable (✓ or ✕)
- Select  and press  to save and exit
-  Cancel (exit without saving changes)

NOTE: Units which can be enabled are TruCheck™ 2 Plus model specific (See Technical Specification).

Click Menu



-   Select menu item (e.g. Sensitivity)
-  Confirm item
-   Change setting (e.g. High to Medium)
-  Confirm setting
- Select  and press  to save and exit
-  Cancel (exit without saving changes)

Setting Options







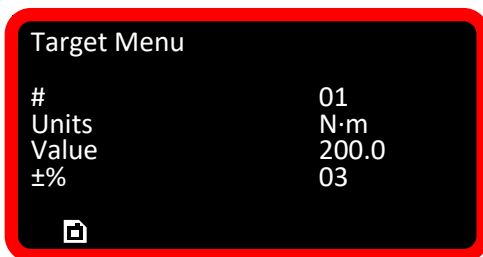

Sensitivity: High / Medium / Low

Reset: Auto / Manual

Hold Time: 1 sec / 2 sec / 3 sec

Target Menu



-   Select menu item (e.g. Units)
-  Confirm item
-   Change setting (e.g. N·m to lbf·ft)
-  Confirm setting
- Select  and press  to save and exit
-  Cancel (exit without saving changes)

Setting Options

(Target No.): 01 – 15

Units: N·m / lbf·ft / etc

Value: 0 or 2 - 100% Capacity
(e.g. 7.0 – 350.0)

±% (Tolerance): 1 – 15%

- When changing the target value, you can press and hold the buttons to speed up the change
- When you change the target units, the target value will change to suit
- Setting the target value to '0' disables it, meaning it won't be selectable in the measure screen

Version Screen

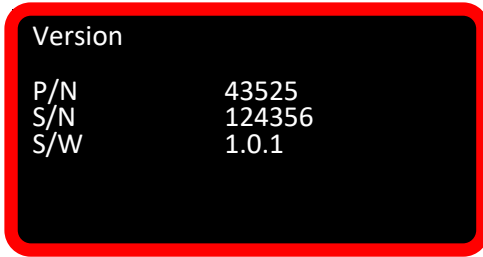

Press and hold  from the measurement screen to view the version screen

The version screen contains:

P/N (Part Number of the TruCheck™ 2 Plus)

S/N (Serial Number)



S/W (Software Version Number)

Press  to return to the measurement screen or

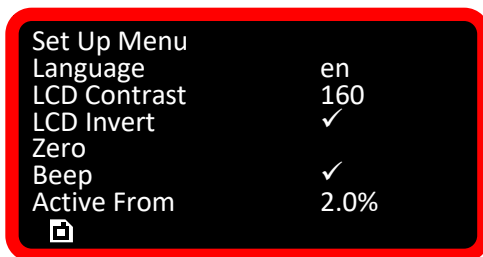

Press  to enter the set up menu

Set Up Menu



  Select menu item (e.g. Language)

 Confirm item

  Change setting (e.g. en to fr)

 Confirm setting

Select  and press  to save and exit

 Cancel (exit without saving changes)

Setting Options

Language: en / fr / de / it / da / es / fi / sv / no / pt

LCD Contrast: 1 – 255 (Default 160)

LCD Invert: Invert (✓) or non-invert (✖)

Zero: Reset the stored Zero value

Beep: Enable (✓) or disable (✖)

Active From: 2.0 to 40.0 % (default 2.0%)

Zero Resetting

Zero resetting should only be performed if the TruCheck™ 2 Plus won't zero in Track mode. If this is the case the transducer may have been overstrained.

If the reading is unstable the TruCheck™ 2 Plus should be returned to a supplier approved agent for repair. It is recommended to get the TruCheck™ 2 Plus recalibrated as soon as possible after resetting the zero. Make sure no torque is being applied to the TruCheck™ 2 Plus and remove any tools from the input drive when resetting the zero.

Active From Setting

This is the percentage of capacity at which Click mode and Dial mode will start to capture peak values.

Target Indication

When a target is selected, the TruCheck™ 2 Plus will indicate whether a reading is Low, Pass or High in three different ways.

1. Text colour (Low = Yellow, Pass = Green, High = Red)
2. Target icons (Low = ▼, Pass = ✓, High = ▲)
3. Target indicator line

Example

Target 1 (T01) Set to **200.0 N·m ±3%** (194.0 – 206.0 N·m)
Mode set to **Click**

First Reading 190.7 N·m (LOW)

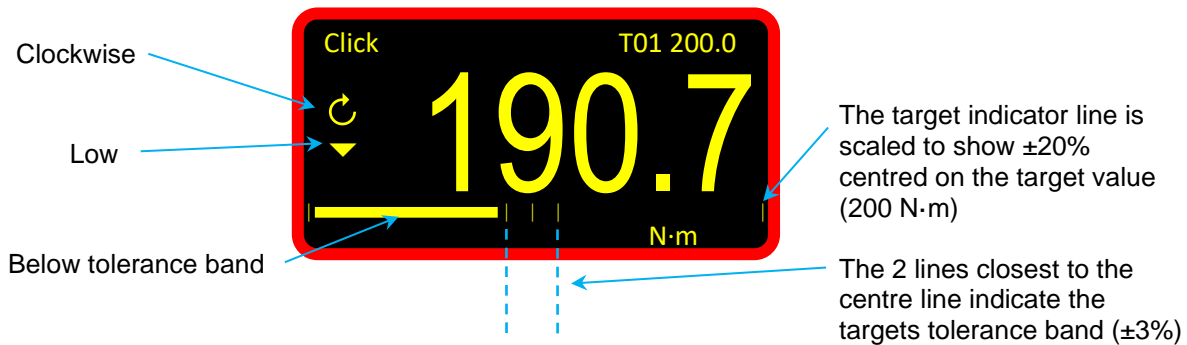

Second Reading 202.1 N·m (PASS)

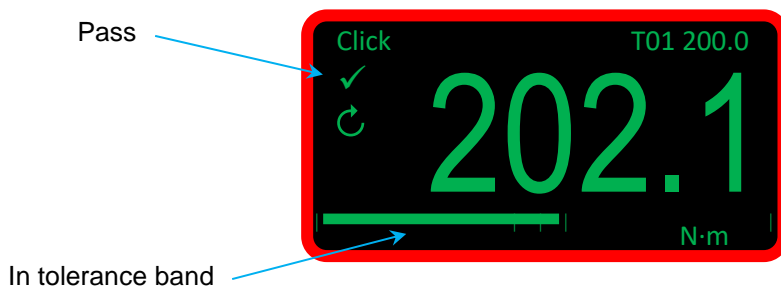

Third Reading 212.4 N·m (HIGH)

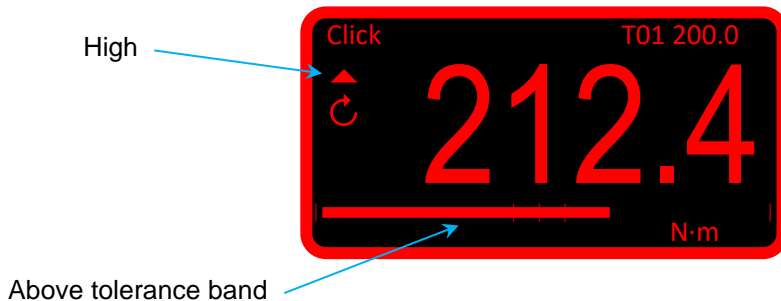

Using the Instrument

1. Select mode of operation
2. Select target
3. Select units
4. Place torque screwdriver / torque wrench in the input drive and operate in the desired direction
5. Remove the torque screwdriver / torque wrench and zero the display (if required) by pressing the RESET button
6. Place the torque screwdriver / torque wrench in the input drive and operate in the desired direction

USB Port

The USB port provides the power for the TruCheck™ 2 Plus. The supplied USB lead can also be used to connect the TruCheck™ 2 Plus to a PC for communication of torque readings.

Connect the TruCheck™ 2 Plus to the PC and a virtual com port will appear in device manager. This com port should be selected and configured to suit the program being used to display the torque readings.

Torque readings will be sent to the PC whenever the RESET button is pressed in any mode and when a peak value is reset (either manually using the RESET button in Dial or Click mode or when auto-reset triggers in Click mode).

If the PC doesn't detect the TruCheck™ 2 Plus correctly (e.g. if running Windows 7 rather than Windows 10) download the USB driver from the Norbar website.

The USB port can also be used to update the TruCheck™ 2 Plus software.

For the USB driver and to update the TruCheck™ 2 software visit:

<https://www.norbar.com/Downloads/Software-Download/Trucheck2>

OPERATING INSTRUCTIONS – TRUCHECK™ 2

(43514, 43516, 43518, 43520, 43522, 43524, 43528, 43530 & 43532)

Measurement Screen

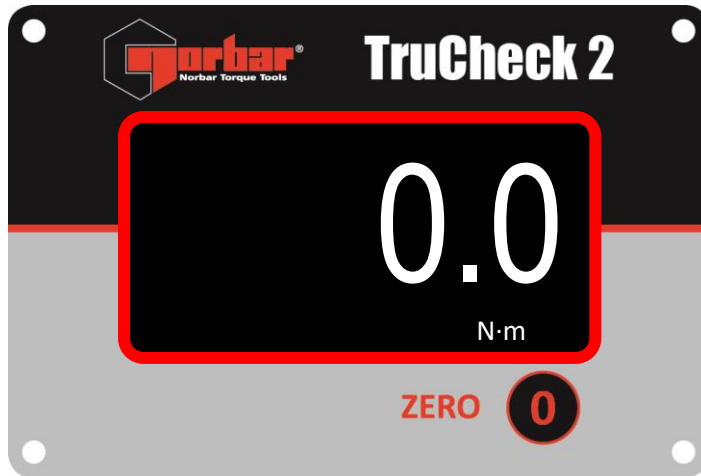

Using the Instrument

1. Place torque screwdriver / torque wrench in the input drive and operate in the desired direction
2. Remove the torque screwdriver / torque wrench and zero the display (if required) by pressing the ZERO button
3. Place the torque screwdriver / torque wrench in the input drive and operate in the desired direction

Version Screen

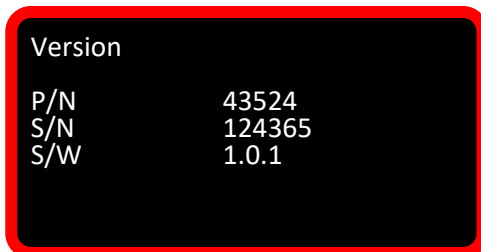

Press and hold the ZERO button from the measurement screen to view the version screen

The version screen contains:

P/N (Part Number of the TruCheck™2)

S/N (Serial Number)

S/W (Software Version Number)

Press the ZERO button to return to the measurement screen

Or

Press and hold the ZERO button for 5 seconds to enter the set up menu

Set Up Menu



Press the ZERO button to select the menu item

Press and hold the ZERO button to confirm/toggle the menu item

Setting Options

- LCD Invert: Invert (✓) or non-invert (✖)
- Beep: Enable (✓) or disable (✖)
- Track: Put the TruCheck™ 2 into Track mode
- Zero: Reset the stored Zero value
- Calibrate: Put the TruCheck™ 2 into Calibrate mode
- X: Exit without saving changes
-  Save changes and exit

Track Mode

Pressing and holding the ZERO button on 'Track' will put the TruCheck™ 2 into Track mode. The TruCheck™ 2 will remain in Track mode until it is disabled in the set up menu, or is power cycled. The TruCheck™ 2 will always power up in its default mode (Click mode).

Zero Resetting

Zero resetting should only be performed if the TruCheck™ 2 won't zero. If this is the case the transducer may have been overstrained.

If the reading is unstable the TruCheck™ 2 should be returned to a supplier approved agent for repair. It is recommended to get the TruCheck™ 2 recalibrated as soon as possible after resetting the zero. Make sure no torque is being applied to the TruCheck™ 2 and remove any tools from the input drive when resetting the zero.

Calibrate Mode

Only to be used by a supplier approved agent.

USB Port

The USB port provides the power for the TruCheck™ 2.
The USB port can also be used to update the TruCheck™ 2 software.

For the USB driver (if required) and to update the TruCheck™ 2 software visit:
<https://www.norbar.com/Downloads/Software-Download/Trucheck2>

SPECIFICATIONS

TruCheck™ 2 (0.1 – 30 N·m)

Part Number	Model	Transducer Input	Capacity	Max Torque
43514	TruCheck™ 2 3 N·m	¼" Male Hex Drive	0.1 - 3 N·m	3.6 N·m
43515	TruCheck™ 2 Plus 3 N·m	¼" Male Hex Drive	0.1 - 3 N·m	3.6 N·m
43516	TruCheck™ 2 10 N·m	¼" Male Hex Drive	0.5 - 10 N·m	12 N·m
43517	TruCheck™ 2 Plus 10 N·m	¼" Male Hex Drive	0.5 - 10 N·m	12 N·m
43518	TruCheck™ 2 30 N·m	10 mm Male Hex Drive	1.5 - 30 N·m	36 N·m
43519	TruCheck™ 2 Plus 30 N·m	10 mm Male Hex Drive	1.5 - 30 N·m	36 N·m

Part Number	Dimensions (mm)										Weight (kg)
	A	B	C	D	E	F	G	ØH	J	K	
43514	175	63.5	63.5	37.5	30	8.5	55	6.5	10	10	1.4
43515	175	63.5	63.5	37.5	30	8.5	55	6.5	10	10	1.4
43516	175	63.5	63.5	37.5	30	8.5	55	6.5	10	10	1.4
43517	175	63.5	63.5	37.5	30	8.5	55	6.5	10	10	1.4
43518	175	63.5	63.5	37.5	30	8.5	55	6.5	10	10	1.4
43519	175	63.5	63.5	37.5	30	8.5	55	6.5	10	10	1.4

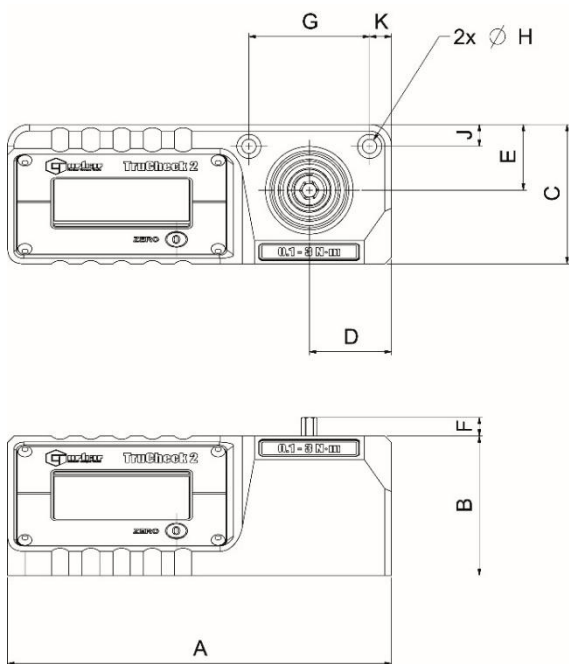

3 N·m & 10 N·m MODELS

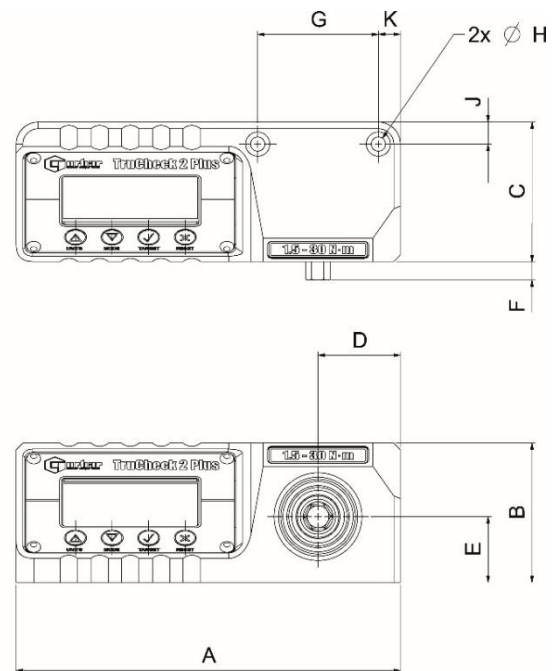

30 N·m MODEL

TruCheck™ 2 (3 – 2,100 N·m)

Part Number	Model	Transducer Input	Capacity	Max Torque
43520	TruCheck™ 2 65 N·m	3/8" Female Square Drive	3 - 65 N·m	78 N·m
43521	TruCheck™ 2 Plus 65 N·m	3/8" Female Square Drive	3 - 65 N·m	78 N·m
43522	TruCheck™ 2 260 lbf·ft	1/2" Female Square Drive	10 - 260 lbf·ft	312 lbf·ft
43523	TruCheck™ 2 Plus 260 lbf·ft	1/2" Female Square Drive	10 - 260 lbf·ft	312 lbf·ft
43524	TruCheck™ 2 350 N·m	1/2" Female Square Drive	10 - 350 N·m	420 N·m
43525	TruCheck™ 2 Plus 350 N·m	1/2" Female Square Drive	10 - 350 N·m	420 N·m
43528	TruCheck™ 2 800 lbf·ft	27 mm Male Hex Drive	40 - 800 lbf·ft	960 lbf·ft
43529	TruCheck™ 2 Plus 800 lbf·ft	27 mm Male Hex Drive	40 - 800 lbf·ft	960 lbf·ft
43530	TruCheck™ 2 1,100 N·m	27 mm Male Hex Drive	50 - 1,100 N·m	1,320 N·m
43531	TruCheck™ 2 Plus 1,100 N·m	27 mm Male Hex Drive	50 - 1,100 N·m	1,320 N·m
43532	TruCheck™ 2 2,100 N·m	27 mm Male Hex Drive	200 - 2,100 N·m	2,310 N·m
43533	TruCheck™ 2 Plus 2,100 N·m	27 mm Male Hex Drive	200 - 2,100 N·m	2,310 N·m

Part Number	Dimensions (mm)												Weight (kg)
	A	B	C	D	E	F	G	ØH	J	K	L	M	
43520	138	117	110	40	40	119	80	10.5	18.5	57.5	59	N/A	2.6
43521	138	117	110	40	40	119	80	10.5	18.5	57.5	59	N/A	2.6
43522	138	117	110	40	40	119	80	10.5	18.5	57.5	59	N/A	2.7
43523	138	117	110	40	40	119	80	10.5	18.5	57.5	59	N/A	2.7
43524	138	117	110	40	40	119	80	10.5	18.5	57.5	59	N/A	2.7
43525	138	117	110	40	40	119	80	10.5	18.5	57.5	59	N/A	2.7
43528	138	132.5	120	40	47.5	144	95	10.5	19	68	67	25	3.5
43529	138	132.5	120	40	47.5	144	95	10.5	19	68	67	25	3.5
43530	138	132.5	120	40	47.5	144	95	10.5	19	68	67	25	3.5
43531	138	132.5	120	40	47.5	144	95	10.5	19	68	67	25	3.5
43532	138	132.5	120	40	47.5	144	95	10.5	19	68	67	25	3.5
43533	138	132.5	120	40	47.5	144	95	10.5	19	68	67	25	3.5

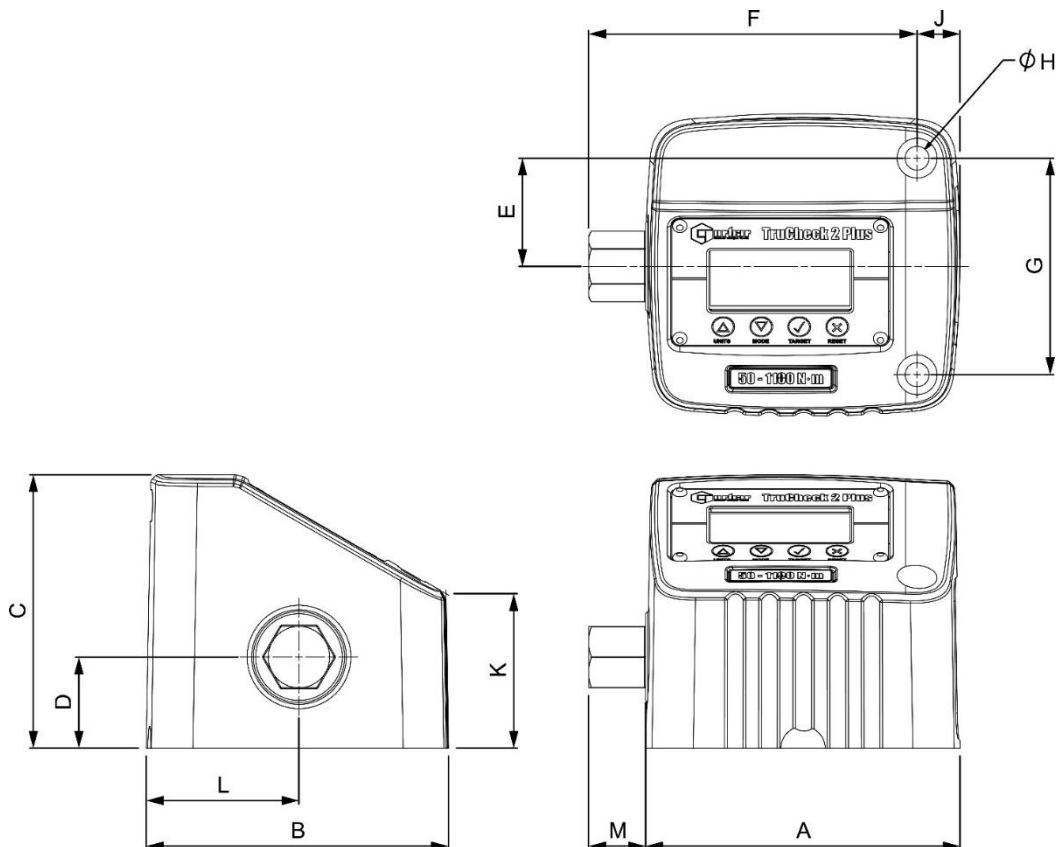

Display: 128 x 64 pixel RGB backlit LCD

Display update rate: 5 readings per second (5Hz)

Resolution: 4 digits

Zero suppression: None

Accuracy: See calibration certificate (Nominally $\pm 1\%$ of reading)

Units of measurement: Available units dependant on specific TruCheck™ 2 Plus model

		N·m	dN·m	cN·m	kgf·m	kgf·cm	gf·m	lbf·ft	lbf·in	ft·lb	in·lb	ozf·in	in·oz
43515	3 N·m	✓	✓	✓		✓	✓	✓	✓	✓	✓	✓	✓
43517	10 N·m	✓	✓	✓	✓	✓	✓	✓	✓	✓	✓	✓	✓
43519	30 N·m	✓	✓	✓	✓	✓	✓	✓	✓	✓	✓	✓	✓
43521	65 N·m	✓	✓	✓	✓	✓	✓	✓	✓	✓	✓	✓	✓
43523	260 lbf·ft	✓	✓		✓	✓		✓	✓	✓	✓		
43525	350 N·m	✓	✓		✓	✓		✓	✓	✓	✓		
43529	800 lbf·ft	✓			✓			✓	✓	✓	✓		
43531	1100 N·m	✓			✓			✓	✓	✓	✓		
43533	2100 N·m	✓			✓			✓		✓			

Auto reset hold time: 3 seconds (Plus models – 1, 2 or 3 seconds)

AC power adapter: 90 to 264 Volts AC at 47 – 63 Hz input (World)
Interchangeable mains connectors included
Energy Efficiency Level VI
5V, 1,000 mA DC USB A output connector

Power consumption: 0.5 W – maximum

Operating temperature range: 0°C to +50°C

Storage temperature range: -20°C to +70°C

Maximum operating humidity: 85% relative humidity at 30°C

Environment: IP 40. Indoor use within a light industrial environment

Maximum working torsion: 120% of rated capacity (except 2100 N·m @ 110%)

Absolute maximum torsion: 150% of rated capacity (except 2100 N·m @ 110%)

Case materials / finish: Powder coated aluminium housing. Stainless steel transducer shaft

Electromagnetic Compatibility: Designed to comply with EN 61326-1.

Low Voltage Directive: Designed to comply with EN 61010-1.
TRANSIENT OVERVOLTAGES up to the levels of OVERVOLTAGE CATEGORY II

NOTE: Due to continuous improvement all specifications are subject to change without prior notice.

CALIBRATION

Your instrument has been supplied with a clockwise certificate of calibration. To maintain the specified accuracy, it is recommended that the instrument is recalibrated at least once per year. Recalibration should be carried out by the supplier or by a supplier approved agent, where all the facilities to ensure the instrument is functioning at maximum accuracy are available.

IMPORTANT: DO NOT REMOVE FRONT PANEL AS THERE ARE NO CALIBRATION SETTINGS INSIDE.

REPAIR

Repair should be carried out by the supplier or by a supplier approved agent, where all the facilities to ensure the instrument is functioning at maximum accuracy are available.

There are no parts for user repair inside the case.

CLEANING

Do not use abrasives or solvent based cleaners.

WARNING

If the instrument is used in a manner not specified by the manufacturer, the protection provided by the equipment may be impaired.

DISPOSAL



This symbol on the product indicates that it must not be disposed of in the general waste.

Please dispose of according to your local recycling laws and regulations.

**NORBAR TORQUE TOOLS LTD**

Wildmere Road, Banbury,
Oxfordshire, OX16 3JU
UNITED KINGDOM
Tel + 44 (0)1295 270333
Email enquiry@norbar.com

**NORBAR TORQUE TOOLS PTE LTD**

194 Pandan Loop
#07-20 Pantech Business Hub
SINGAPORE 128383
Tel + 65 6841 1371
Email enquires@norbar.sg

**NORBAR TORQUE TOOLS**

45–47 Raglan Avenue, Edwardstown,
SA 5039
AUSTRALIA
Tel + 61 (0)8 8292 9777
Email enquiry@norbar.com.au

**NORBAR TORQUE TOOLS (SHANGHAI) LTD**

91 Building- 7F, No. 1122, Qinzhou North Road,
Xuhui District, Shanghai
CHINA 201103
Tel + 86 21 6145 0368
Email sales@norbar.com.cn

**NORBAR TORQUE TOOLS INC**

36400 Biltmore Place, Willoughby,
Ohio, 44094
USA
Tel + 1 866 667 2279
Email inquiry@norbar.us

**NORBAR TORQUE TOOLS INDIA PVT. LTD**

Plot No A-168, Khairne Industrial Area,
Thane Belapur Road, Mahape,
Navi Mumbai – 400 709
INDIA
Tel + 91 22 2778 8480
Email enquiry@norbar.in

www.norbar.com