



Buchanan

TE Internal #: 1-1546671-0

Barrier Strips, Dual Barrier, Quick Connects, Wire-to-Wire, 10 Position, 11.1 mm [.438 in] Centerline, 2 Row, 300 V, 22 – 14 AWG Wire Size

[View on TE.com >](#)

Connectors > Terminal Blocks & Strips > Barrier Strips

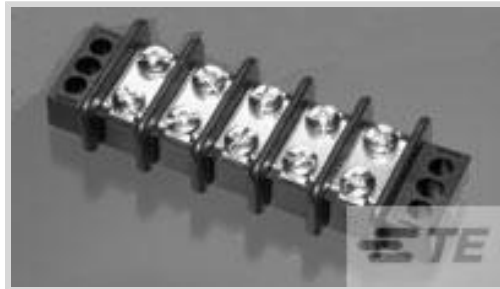

Barrier Strip Style: **Dual Barrier**

Bottom Termination Type: **Quick Connects**

Connector System: **Wire-to-Wire**

Number of Positions: **10**

Centerline (Pitch): **11.1 mm [.438 in]**

Features

Product Type Features

Product Type	Barrier Strip
Block Style	Flat
Connector System	Wire-to-Wire
Connector & Contact Terminates To	Wire & Cable

Configuration Features

Number of Levels	1
Number of Positions	10
Number of Rows	2

Electrical Characteristics

Current Rating (Max)	25 A
Voltage Rating	300 V

Body Features

Color	Black
Barrier Strip Style	Dual Barrier

Contact Features

Terminal Material	Brass
Terminal Plating Material	Tin
Contact Current Rating (Max)	25 A



Termination Features

Bottom Termination Type	Quick Connects
-------------------------	----------------

Mechanical Attachment

Mounting Angle	Vertical
Screw Head Type	Wire Clamp Combo Head
Top Termination Type	Wire Clamp Combo Head
Mounting Insert	Without
Screw Plating Material	Nickel
Screw Material	Steel
Mounting Options	End Mounting Ears
Mounting Ears	With
Screw Size	6-32
Connector Mounting Type	Panel Mount

Housing Features

Housing Material	Thermoplastic
Centerline (Pitch)	11.1 mm [.438 in]

Dimensions

Length	130 mm [5.12 in]
Wire Size	.3 – 2 mm ²

Usage Conditions

Operating Temperature Range	-40 – 120 °C [-40 – 248 °F]
-----------------------------	-----------------------------

Operation/Application

Circuit Application	Power
---------------------	-------

Industry Standards

UL Flammability Rating	UL 94V-0
------------------------	----------

Packaging Features

Packaging Quantity	50
Packaging Method	Carton

Other

Comment	Other options available upon request, consult our Product Information Center.
---------	---

Product Compliance

For compliance documentation, visit the product page on [TE.com](#)>

EU RoHS Directive 2011/65/EU	Compliant
EU ELV Directive 2000/53/EC	Compliant
China RoHS 2 Directive MIIT Order No 32, 2016	No Restricted Materials Above Threshold
EU REACH Regulation (EC) No. 1907/2006	Current ECHA Candidate List: JAN 2022 (223) Candidate List Declared Against: JAN 2022 (223) Does not contain REACH SVHC
Halogen Content	Low Halogen - Br, Cl, F, I < 900 ppm per homogenous material. Also BFR/CFR/PVC Free
Solder Process Capability	Wave solder capable to 265°C

Product Compliance Disclaimer

This information is provided based on reasonable inquiry of our suppliers and represents our current actual knowledge based on the information they provided. This information is subject to change. The part numbers that TE has identified as EU RoHS compliant have a maximum concentration of 0.1% by weight in homogenous materials for lead, hexavalent chromium, mercury, PBB, PBDE, DBP, BBP, DEHP, DIBP, and 0.01% for cadmium, or qualify for an exemption to these limits as defined in the Annexes of Directive 2011/65/EU (RoHS2). Finished electrical and electronic equipment products will be CE marked as required by Directive 2011/65/EU. Components may not be CE marked. Additionally, the part numbers that TE has identified as EU ELV compliant have a maximum concentration of 0.1% by weight in homogenous materials for lead, hexavalent chromium, and mercury, and 0.01% for cadmium, or qualify for an exemption to these limits as defined in the Annexes of Directive 2000/53/EC (ELV). Regarding the REACH Regulation, the information TE provides on SVHC in articles for this part number is based on the latest European Chemicals Agency (ECHA) 'Guidance on requirements for substances in articles' posted at this URL: <https://echa.europa.eu/guidance-documents/guidance-on-reach>

Compatible Parts

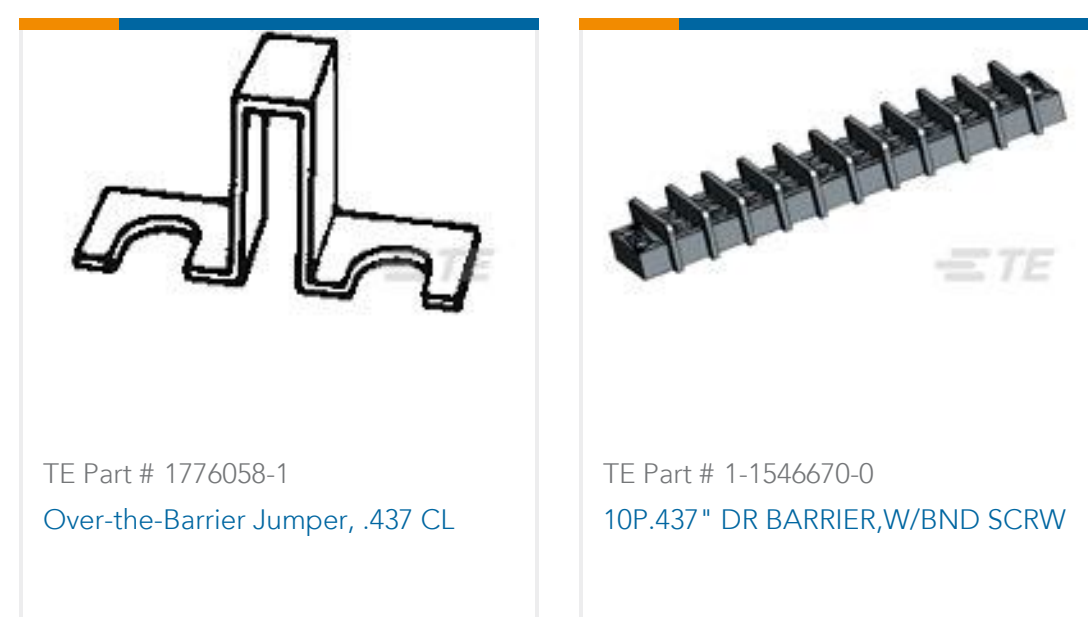

Customers Also Bought



TE Part #5745784-4
37 MSFL RCPT RA 318 (IN,FM)



TE Part #1-1437565-8
FSM1LPATR=TACT SWITCH 6X6MIL S



TE Part #770986-1
MINI UMNL SOK 26-22AWG SN LP



TE Part #5556416-1
MJ,TE,8P



TE Part #5745116-1
50 RCPT RA/MS STD



TE Part #1-2176380-3
RQ 0805 1K54 0.1% 10PPM 5K RL



TE Part #2-1879351-5
RR01 5% 30K AMMO

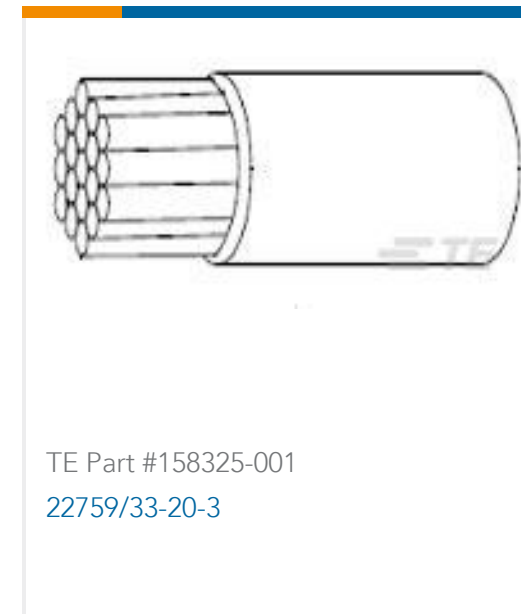

TE Part #158325-001
22759/33-20-3

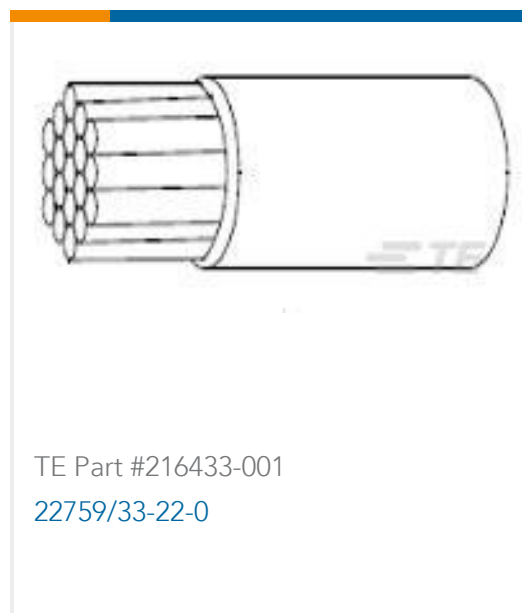

TE Part #216433-001
22759/33-22-0

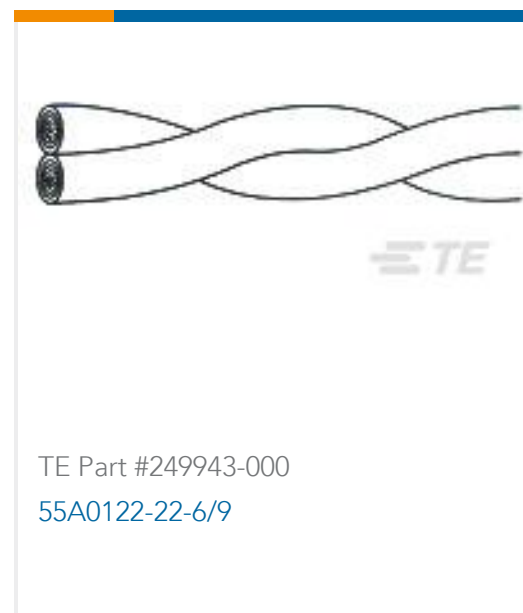

TE Part #249943-000
55A0122-22-6/9

Documents

Product Drawings

[10P.437" DR BARRIER,W/WIR CLMP](#)

English

CAD Files

[3D PDF](#)

3D

Customer View Model

[ENG_CVM_CVM_1-1546671-0_C_c-1-1546671-0-c.2d_dxf.zip](#)

English

Customer View Model

[ENG_CVM_CVM_1-1546671-0_C_c-1-1546671-0-c.3d_igs.zip](#)

English

Customer View Model

[ENG_CVM_CVM_1-1546671-0_C_c-1-1546671-0-c.3d_stp.zip](#)

English

By downloading the CAD file I accept and agree to the [Terms and Conditions](#) of use.

Datasheets & Catalog Pages

1-1546671-0

Barrier Strips, Dual Barrier, Quick Connects, Wire-to-Wire, 10 Position, 11.1 mm [.438 in] Centerline, 2 Row, 300 V, 22 – 14 AWG Wire Size



[BUCHANAN TERMINAL BLOCKS CATALOG - BARRIER STRIPS](#)

English

[1-1773458-2_BARRIER_STRIPS_QUICK_REFERENCE_GUIDE](#)

English