

# PFH COMPACT FAN HEATER 900 W

- 400V heater power supply
- high power to size ratio ⇒ small, compact design
- fast heating due to PTC technology
- wall or DIN rail mounting
- low surface temperature
- finger guard at inlet and outlet



PRODUCT		PFH 900	
ARTICLE NO.	400 V	17090602130	Unit
<b>DATA</b>			
Heating performance (Ta = +10 °C)		900	W
Max. starting current (400 V)		6	A
Max. pre fuse T		10	
Max. surface temperature during UL locked rotor test		90	°C
Power consumption fan		5	W
Volumetric air flow		94	m³/h
Operating temperature		-40 ... +70	°C
System of protection for intended purpose of use		IP20	
Rated voltage ±10 % heating element		AC 50   60 Hz	
		400   480	V
Rated voltage ±10 % fan		DC	
		24	V
Protection class		II	
Thermal protection		PTC technology / passing UL locked rotor test	
Device construction		plastic UL 94V-0, black	
Type of mounting		snap fastening for 35 mm profile bars according to EN 60715   4 x M5 screws (not included)	
Type of connection		plug terminal connector	
Weight		740	g

For additional models, options and voltages visit [www.pfannenberg.com](http://www.pfannenberg.com) or contact us directly.

**Dimensions mm**

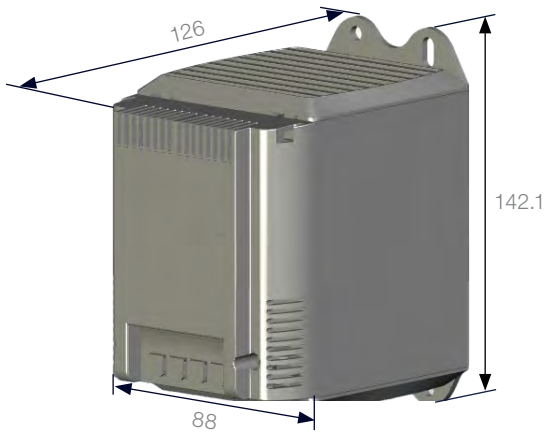

**Schematics**

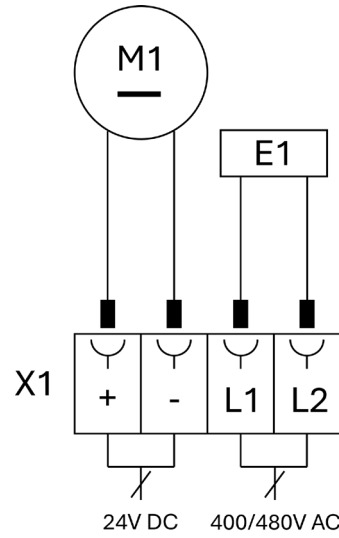

M1: fan  
E1: PTC - heating element  
X1: connection

**Diagrams**

