

THIS DRAWING IS UNPUBLISHED. RELEASED FOR PUBLICATION
 © COPYRIGHT 19 BY AMP INCORPORATED. ALL INTERNATIONAL RIGHTS RESERVED.

LOC	DIST	P	F	ZONE	LTR	REVISIONS	DATE	APPD
G	14				H	REV / 0G10-0026-99	12FEB99	MLE SU

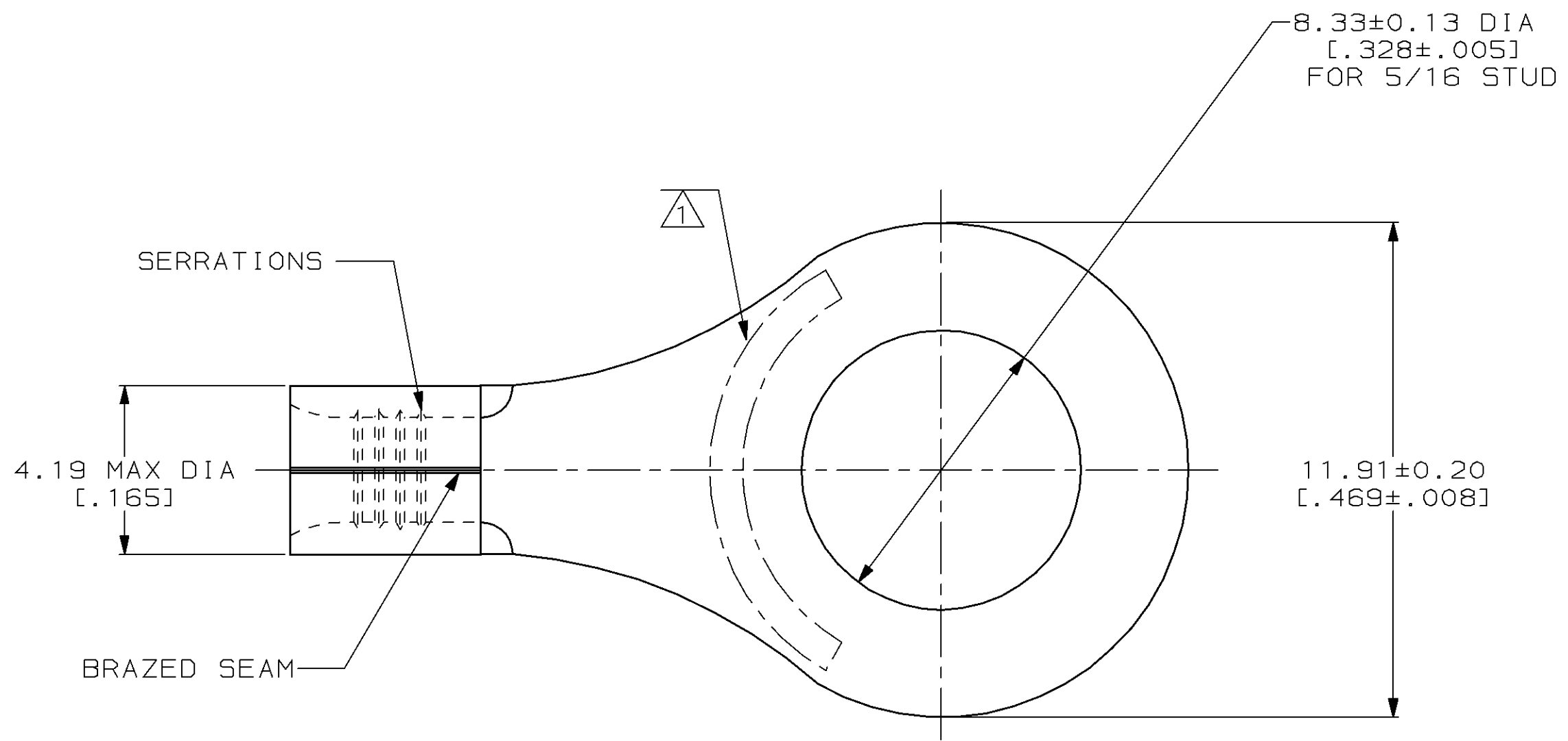

AMP WIRE RANGE	UL E13288 Listed
16-14 AWG SOLID OR STRANDED	16-14 AWG SOLID OR STRANDED
LR7189 Certified	MILITARY P/N AND CLASS
16-14 AWG SOLID OR STRANDED	SEE TABLE BELOW

- ① STAMP AMP 16-14* APPROX AS SHOWN
- ② THIS IS NOT A U.S. MILITARY QUALIFIED PART

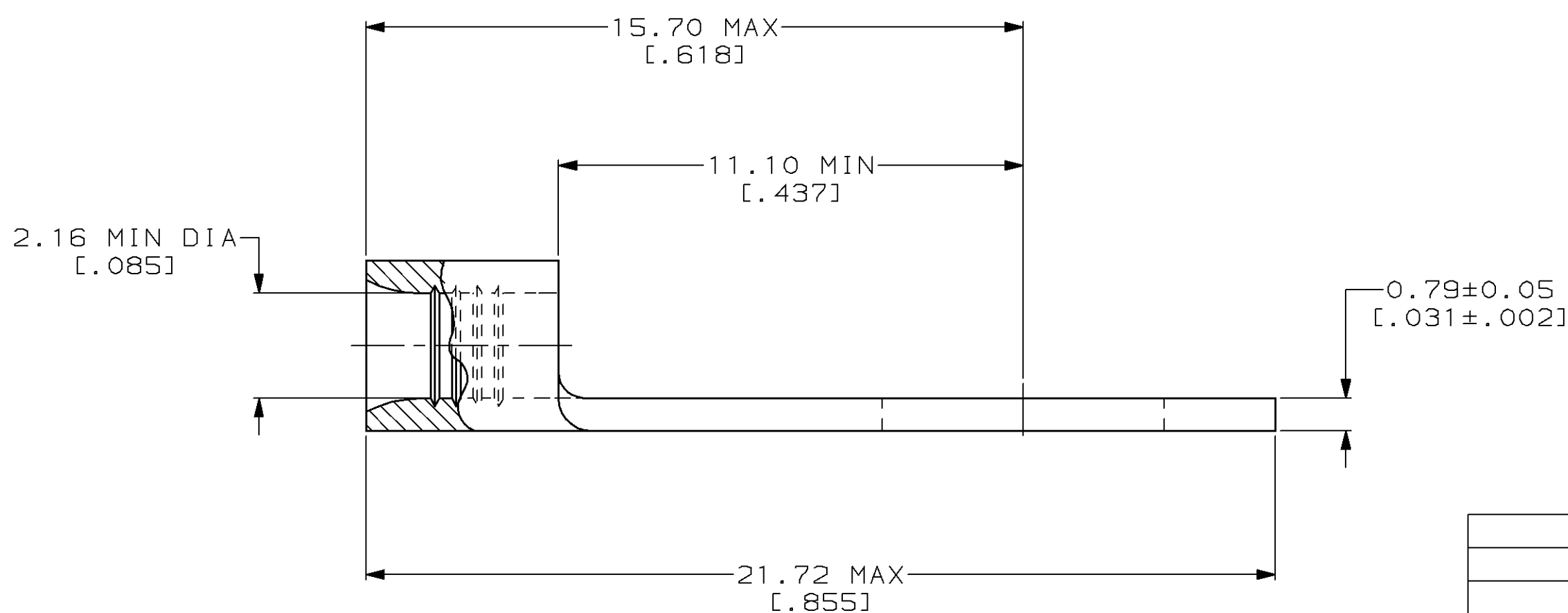

MILITARY P/N AND CLASS	QUANTITY	PACKAGING TYPE	AMP PART NUMBER
②-	100	ON TAPE, REEL	8-34125-5
②-	100	LOOSE PIECE	8-34125-1
②-	5000	LOOSE PIECE, SPECIAL BOX	3-34125-2
②-	1000	LOOSE PIECE, BOX	3-34125-1
M7928/7-9 CLASS 2	5000	ON TAPE, REEL	2-34125-6
M7928/7-9 CLASS 2	1000	LOOSE PIECE	34125

AMP INCORPORATED
CUSTOMER SERVICE SYSTEMS

FOR ADDITIONAL PRODUCT INFORMATION OR COPIES OF DRAWINGS AND TECHNICAL DOCUMENTS

FOR APPLICATION TOOLING INFORMATION

FOR ORDER ENTRY

PRODUCT INFORMATION CENTER
 1-800-522-6752

TOOLING ASSISTANCE CENTER
 1-800-722-1111

1-800-526-5142

MAX RECOMMENDED OPERATING TEMPERATURE:
 170°C MAX

VOLTAGE RATING:
 NOT APPLICABLE

WIRE CROSS SECTIONAL AREA RANGE:
 1.04-2.62mm² [2,050-5,180] CIR MILS
 SOLID OR STRANDED

THIS DRAWING IS A CONTROLLED DOCUMENT FOR AMP INCORPORATED. IT IS SUBJECT TO CHANGE AND THE CONTROLLING ENGINEERING ORGANIZATION SHOULD BE CONTACTED FOR THE LATEST REVISION.

DO NOT SCALE PRINT. UNLESS SPECIFIED DIMENSIONS IN mm [INCHES] TOLERANCES ON:

2 PLC DEC ± -
 3 PLC DEC ± -
 ANGLES ± -

MATERIAL
 COPPER PER ASTM B-152 ANNEALED

FINISH
 TIN PLATE 0.00254 [0.000100] MIN THK PER ASTM B-545

DR 3-17-93
 TA BRINKMAN

CHK 3-17-93
 DA PATTERSON

APPD 3-17-93
 DE MILLER

APPD 3-17-93
 JL MECKLEY

PRODUCT SPEC -

APPLICATION SPEC -

WEIGHT -

AMP AMP Incorporated
 Harrisburg, PA 17105-3608

NAME
TERMINAL, RING TONGUE, SOLISTRAND™

SIZE
 C 00779

CAGE CODE
 00779

DRAWING NO
 C=34125

SCALE
 8:1

SHEET
 1 OF 1