

# 42 mm sq. (1.65 inch sq.)

1.8° /step RoHS

**Unipolar winding, Connector type**  
Bipolar winding, Lead wire type ▶ p. 62

### Customizing

- Hollow Shaft modification
- Decelerator Encoder
- Brake

Varies depending on the model number and quantity. Contact us for details.

### Unipolar winding, Connector type

Model number		Holding torque at 2-phase energization	Rated current	Wiring resistance	Winding inductance	Rotor inertia	Mass (Weight)	Motor length (L)
Single shaft	Dual shaft	[N·m (oz·in) min.]	A/phase	Ω /phase	mH/phase	[× 10 <sup>-4</sup> kg·m <sup>2</sup> (oz·in <sup>2</sup> )]	[kg (lbs)]	mm (in)
<b>103H5205-0440</b>	<b>103H5205-0410</b>	0.2 (28.32)	1.2	2.4	2.3	0.036 (0.20)	0.23 (0.51)	33 (1.25)
<b>103H5208-0440</b>	<b>103H5208-0410</b>	0.3 (42.48)	1.2	2.9	3.4	0.056 (0.31)	0.29 (0.64)	39 (1.54)
<b>103H5209-0440</b>	<b>103H5209-0410</b>	0.32 (45.31)	1.2	3	3.9	0.062 (0.34)	0.31 (0.68)	41 (1.61)
<b>103H5210-0440</b>	<b>103H5210-0410</b>	0.37 (52.39)	1.2	3.3	3.4	0.074 (0.40)	0.37 (0.82)	<b>48 (1.89)</b>

Motor cable: Model No.4835710-1

## Characteristics diagram

### 103H5205-0440 103H5205-0410

Constant current circuit  
Source voltage: 24 VDC  
Operating current:  
1.2 A/phase, 2-phase energization (full-step)  
 $J_L=[0.94 \times 10^{-4} \text{kg}\cdot\text{m}^2 (5.14 \text{oz}\cdot\text{in}^2)]$  use the rubber coupling]  
fs: Maximum self-start frequency when not loaded

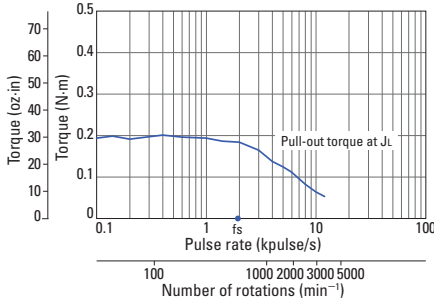

### 103H5208-0440 103H5208-0410

Constant current circuit  
Source voltage: 24 VDC  
Operating current:  
1.2 A/phase, 2-phase energization (full-step)  
 $J_L=[0.94 \times 10^{-4} \text{kg}\cdot\text{m}^2 (5.14 \text{oz}\cdot\text{in}^2)]$  use the rubber coupling]  
fs: Maximum self-start frequency when not loaded

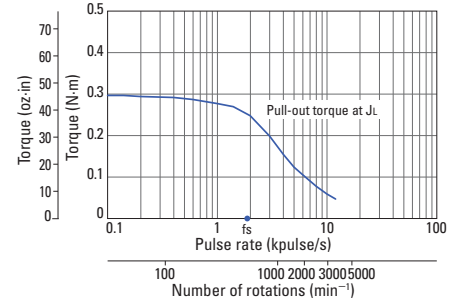

### 103H5209-0440 103H5209-0410

Constant current circuit  
Source voltage: 24 VDC  
Operating current:  
1.2 A/phase, 2-phase energization (full-step)  
 $J_L=[0.94 \times 10^{-4} \text{kg}\cdot\text{m}^2 (5.14 \text{oz}\cdot\text{in}^2)]$  use the rubber coupling]  
fs: Maximum self-start frequency when not loaded

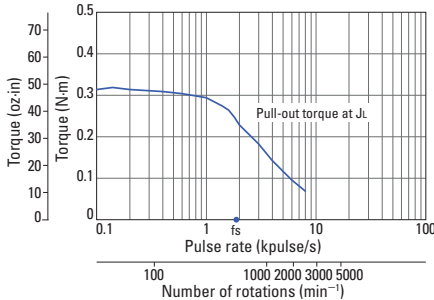

### 103H5210-0440 103H5210-0410

Constant current circuit  
Source voltage: 24 VDC  
Operating current:  
1.2 A/phase, 2-phase energization (full-step)  
 $J_L=[0.94 \times 10^{-4} \text{kg}\cdot\text{m}^2 (5.14 \text{oz}\cdot\text{in}^2)]$  use the rubber coupling]  
fs: Maximum self-start frequency when not loaded

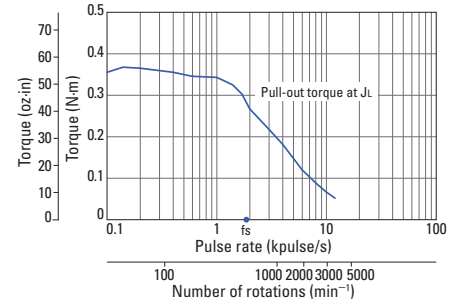

## Dimensions [Unit: mm (inch)]

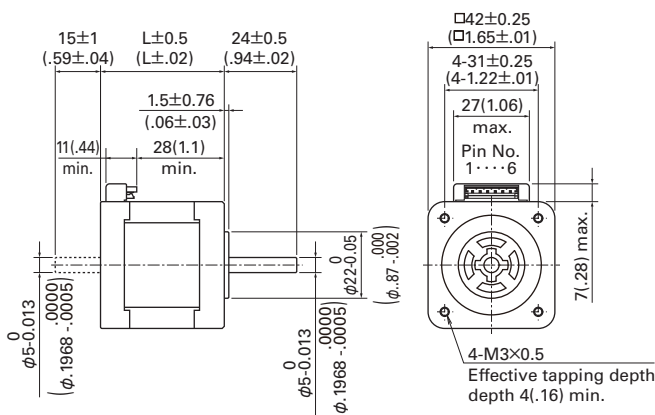

Option (sold separately): Motor cable Model number: 4835710-1

Manufacturer: J.S.T. Mfg. Co., Ltd.  
Housing: EHR-6 Black  
Pin: SEH-001T-P0.6

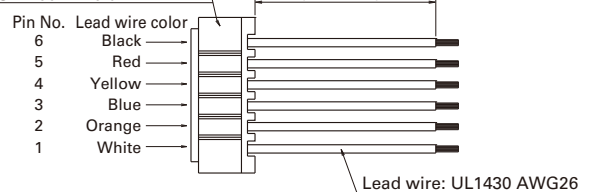

This driver-motor cable is for motor model numbers 103H52□□-04□□.

## Internal wiring

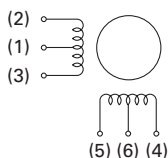

## Compatible drivers

Model number: US1D200P10

Operating current select switch setting: 8

The characteristics diagram shown above is from our experimental circuit.

# Allowable Radial/Thrust Load

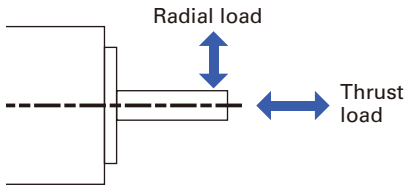

Flange size	Model number	Distance from end of shaft : mm (in)				Thrust load N (lbs)
		0	5	10	15	
Radial load : N (lbs)						
14 mm sq. (0.55 in sq.)	SH2141	10 (2.25)	11 (2.47)	13 (2.92)	-	0.7 (0.16)
28 mm sq. (1.10 in sq.)	SH228 □	42 (9)	48 (10)	56 (12)	66 (14)	3 (0.67)
35 mm sq. (1.38 in sq.)	SH353 □	40 (8)	50 (11)	67 (15)	98 (22)	10 (2.25)
42 mm sq. (1.65 in sq.)	103H52 □□	22 (4)	26 (5)	33 (7)	46 (10)	10 (2.25)
	SH142 □					
50 mm sq. (1.97 in sq.)	103H670 □	71 (15)	87 (19)	115 (25)	167 (37)	15 (3.37)
56 mm sq. (2.20 in sq.)	103H712 □	85 (19)	105 (23)	138 (31)	200 (44)	15 (3.37)
	103H7128					
60 mm sq. (2.36 in sq.)	103H782 □	70 (15)	87 (19)	114 (25)	165 (37)	20 (4.50)
	SH160 □					
86 mm sq. (3.39 in sq.)	SM286 □	167 (37)	193 (43)	229 (51)	280 (62)	60 (13.488)
	SH286 □					
86 mm sq. (3.39 in sq.)	103H822 □	191 (43)	234 (53)	301 (68)	421 (95)	60 (13.488)
φ 106 mm (φ 4.17 in)	103H8922 □	321 (72)	356 (79)	401 (90)	457 (101)	100 (22.48)

## Internal Wiring and Rotation Direction

### Unipolar winding

Connector type Model number: 103H52 □□

#### Internal wire connection

( ) connector pin number

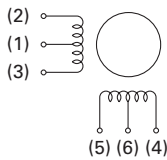

#### Direction of motor rotation

When excited by a direct current in the order shown below, the direction of rotation is clockwise as viewed from the output shaft side.

Exciting order	Connector pin number				
	(1.6)	(5)	(3)	(4)	(2)
1	+	-	-	-	-
2	+	-	-	-	-
3	+	-	-	-	-
4	+	-	-	-	-

Connector type Model number: 103H782 □□

#### Internal wire connection

( ) connector pin number

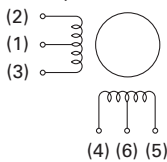

#### Direction of motor rotation

When excited by a direct current in the order shown below, the direction of rotation is clockwise as viewed from the output shaft side.

Exciting order	Connector pin number				
	(1.6)	(4)	(3)	(5)	(2)
1	+	-	-	-	-
2	+	-	-	-	-
3	+	-	-	-	-
4	+	-	-	-	-

Lead wire type

#### Internal wire connection

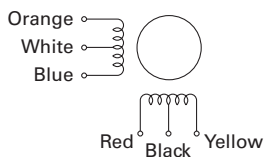

#### Direction of motor rotation

When excited by a direct current in the order shown below, the direction of rotation is clockwise as viewed from the output shaft side.

Exciting order	Lead wire color				
	White & black	Red	Blue	Yellow	Orange
1	+	-	-	-	-
2	+	-	-	-	-
3	+	-	-	-	-
4	+	-	-	-	-

### Bipolar winding

Connector type

#### Internal wire connection

( ) connector pin number, terminal block number

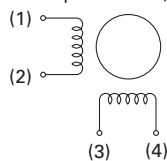

#### Direction of motor rotation

When excited by a direct current in the order shown below, the direction of rotation is clockwise as viewed from the output shaft side.

Exciting order	Connector pin number, terminal block number			
	(3)	(2)	(4)	(1)
1	-	-	+	+
2	+	-	-	+
3	+	+	-	-
4	-	+	+	-

Lead wire type

#### Internal wire connection

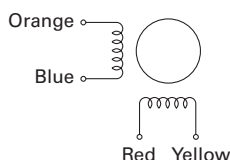

#### Direction of motor rotation

When excited by a direct current in the order shown below, the direction of rotation is clockwise as viewed from the output shaft side.

Exciting order	Lead wire color			
	Red	Blue	Yellow	Orange
1	-	-	+	+
2	+	-	-	+
3	+	+	-	-
4	-	+	+	-

## General Specifications

Motor model number	SH2141	SH228 <input type="checkbox"/>	SH353 <input type="checkbox"/>	SS242 <input type="checkbox"/>	SH142 <input type="checkbox"/>	103H52 <input type="checkbox"/>	SS250 <input type="checkbox"/>	103H67 <input type="checkbox"/>	103H712 <input type="checkbox"/>
Type	-								
Operating ambient temperature	- 10°C to + 50°C								
Conversation temperature	- 20°C to + 65°C								
Operating ambient humidity	20 to 90% RH (no condensation)								
Conversation humidity	5 to 95% RH (no condensation)								
Operation altitude	1000 m (3281 feet) max. above sea level								
Vibration resistance	Vibration frequency 10 to 500 Hz, total amplitude 1.52 mm (10 to 70 Hz), vibration acceleration 150 m/s <sup>2</sup> (70 to 500 Hz), sweep time 15 min/cycle, 12 sweeps in each X, Y and Z direction.								
Impact resistance	500 m/s <sup>2</sup> of acceleration for 11 ms with half-sine wave applying three times for X, Y, and Z axes each, 18 times in total.								
Insulation class	Class B (+130°C)								
Withstandable voltage	At normal temperature and humidity, no failure with 500 VAC @50/60 Hz applied for one minute between motor winding and frame.						At normal temperature and humidity, no failure with 1000 VAC @50/60 Hz applied for one minute between motor winding and frame.		
Insulation resistance	At normal temperature and humidity, not less than 100 MΩ between winding and frame by 500 VDC megger.								
Protection grade	IP40								
Winding temperature rise	80 K max. (Based on Sanyo Denki standard)								
Static angle error	± 0.09°				± 0.054°		± 0.09°		
Thrust play *1	0.075 mm (0.003 in) max. (load: 0.35 N (0.08 lbs))	0.075 mm (0.003 in) max. (load: 1.5 N (0.34 lbs))	0.075 mm (0.003 in) max. (load: 5 N (1.12 lbs))	0.075 mm (0.003 in) max. (load: 4 N (0.9 lbs))	0.075 mm (0.003 in) max. (load: 5 N (1.12 lbs))	0.075 mm (0.003 in) max. (load: 5 N (1.12 lbs))	0.075 mm (0.003 in) max. (load: 4 N (0.9 lbs))	0.075 mm (0.003 in) max. (load: 10 N (2.25 lbs))	0.075 mm (0.003 in) max. (load: 10 N (2.25 lbs))
Radial play *2	0.025 mm (0.001 in) max. (load: 5 N (1.12 lbs))								
Shaft runout	0.025 mm (0.001 in)								
Concentricity of mounting pilot relative to shaft	φ 0.05 mm (φ 0.002 in)	φ 0.05 mm (φ 0.002 in)	φ 0.075 mm (φ 0.003 in)	φ 0.075 mm (φ 0.003 in)	φ 0.05 mm (φ 0.002 in)	φ 0.05 mm (φ 0.002 in)	φ 0.075 mm (φ 0.003 in)	φ 0.075 mm (φ 0.003 in)	φ 0.075 mm (φ 0.003 in)
Squareness of mounting surface relative to shaft	0.1 mm (0.004 in)	0.1 mm (0.004 in)	0.1 mm (0.004 in)	0.1 mm (0.004 in)	0.1 mm (0.004 in)	0.1 mm (0.004 in)	0.1 mm (0.004 in)	0.075 mm (0.003 in)	0.075 mm (0.003 in)
Direction of motor mounting	Can be freely mounted vertically or horizontally								

Motor model number	SH160 <input type="checkbox"/>	103H78 <input type="checkbox"/>	SH286 <input type="checkbox"/>	103H8922 <input type="checkbox"/>	SM286 <input type="checkbox"/>	103H712 <input type="checkbox"/> -6 <input type="checkbox"/> 0 CE Model	103H822 <input type="checkbox"/> -6 <input type="checkbox"/> 0 CE Model	103H8922 <input type="checkbox"/> -63 <input type="checkbox"/> 1 CE Model	
Type	-				S1 (continuous operation)				
Operating ambient temperature	- 10°C to + 50°C				- 10°C to + 40°C				
Conversation temperature	- 20°C to + 65°C				- 20°C to + 60°C				
Operating ambient humidity	20 to 90% RH (no condensation)				95% max.: 40°C max., 57% max.: 50°C max., 35% max.: 60°C max. (no condensation)				
Conversation humidity	5 to 95% RH (no condensation)								
Operation altitude	1000 m (3280 feet) max. above sea level								
Vibration resistance	Vibration frequency 10 to 500 Hz, total amplitude 1.52 mm (10 to 70 Hz), vibration acceleration 150 m/s <sup>2</sup> (70 to 500 Hz), sweep time 15 min/cycle, 12 sweeps in each X, Y and Z direction.								
Impact resistance	500 m/s <sup>2</sup> of acceleration for 11 ms with half-sine wave applying three times for X, Y and Z axes each, 18 times in total.								
Insulation class	Class B (+130°C)				Class F (+155°C)		Class B (+130°C)		
Withstandable voltage	At normal temperature and humidity, no failure with 1000 VAC @50/60 Hz applied for one minute between motor winding and frame.				At normal temperature and humidity, no failure with 1500 VAC @50/60 Hz applied for one minute between motor winding and frame.				
Insulation resistance	At normal temperature and humidity, not less than 100 MΩ between winding and frame by 500 VDC megger.								
Protection grade	IP40				IP43				
Winding temperature rise	80 K max. (Based on Sanyo Denki standard)								
Static angle error	± 0.054°		± 0.09°						
Thrust play *1	0.075 mm (0.003 in) max. (load: 10 N (2.25 lbs))								
Radial play *2	0.025 mm (0.001 in) (load: 5 N (1.12 lbs))	0.025 mm (0.001 in) (load: 5 N (1.12 lbs))	0.025 mm (0.001 in) (load: 5 N (1.12 lbs))	0.025 mm (0.001 in) (load: 10 N (2.25 lbs))	0.025 mm (0.001 in) (load: 5 N (1.12 lbs))	0.025 mm (0.001 in) (load: 5 N (1.12 lbs))	0.025 mm (0.001 in) (load: 5 N (1.12 lbs))	0.025 mm (0.001 in) (load: 10 N (2.25 lbs))	0.025 mm (0.001 in) (load: 10 N (2.25 lbs))
Shaft runout	0.025 mm (0.001 in)								
Concentricity of mounting pilot relative to shaft	φ 0.075 mm (φ 0.003 in)								
Squareness of mounting surface relative to shaft	0.1 mm (0.004 in)	0.075 mm (0.003 in)	0.15 mm (0.006 in)	0.1 mm (0.004 in)	0.15 mm (0.006 in)	0.075 mm (0.003 in)	0.1 mm (0.004 in)	0.1 mm (0.004 in)	0.1 mm (0.004 in)
Direction of motor mounting	Can be freely mounted vertically or horizontally								

\*1 Thrust play: Shaft displacement under axial load.

\*2 Radial play: Shaft displacement under radial load applied 1/3rd of the length from the end of the shaft.

### Safety standards

Model Number: SM286  CE/UL marked models

CE (TÜV)	Standard category		Applicable standard
	Low-voltage directives		EN60034-1, EN60034-5
UL	Acquired standards	Applicable standard	File No.
	UL	UL1004-1, UL1004-6	E179832
	UL for Canada	CSA C22.2 No.100	

Model Number: 103H712  -6  0, 103H822  -6  0, 103H8922  -63  1 CE marked model

CE (TÜV)	Standard category		Applicable standard
	Low-voltage directives		EN60034-1, EN60034-5

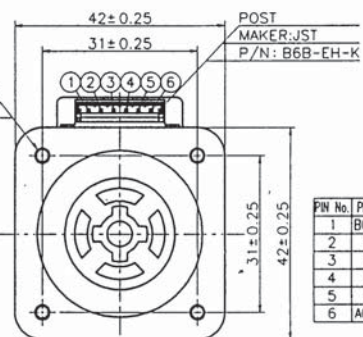
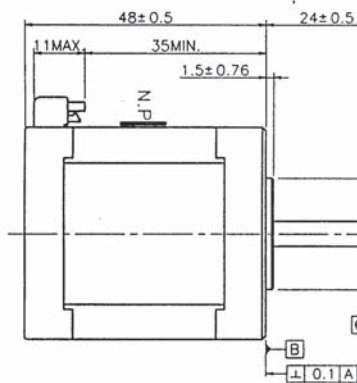
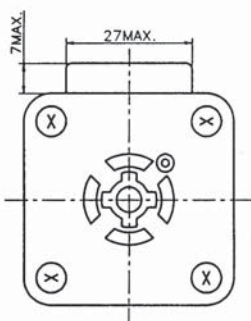

PIN No.	PHASE	LEADS COLOR
1	BCOM	WHITE
2	B	ORANGE
3	B	BULE
4	A	YELLOW
5	A	RED
6	ACOM	BLACK

**RATED CHARACTERISTICS**

PHASES	2
FUNDAMENTAL STEP ANGLE	1.8°
VOLTS	4 V [DC]
AMPS	1.2 A/PHASE
WINDING RESISTANCE	3.3 Ω ± 10% at 25 °C
WINDING INDUCTANCE	3.4 mH ± 20% at 1 kHz 1 V [rms]
HOLDING TORQUE	0.37 N·m MIN. at I=1.2 A/PHASE 2EX
NOTE1. PULL OUT TORQUE	0.285 N·m MIN. at 1000 pulse/s
	LOAD INERTIA 0.94 × 10 <sup>-4</sup> kg·m <sup>2</sup>
	(INCLUDE COUPLING INERTIA)
NOTE1. MAX. STARTING RATE	1500 pulse/s MIN. at NO LOAD
NOTE1. MAX. SLEWING RATE	2100 pulse/s MIN. at NO LOAD
POSITIONAL ACCURACY	± 0.09° (0.18° SPREAD MAX.) 2EX
NOTE2. COIL TEMPERATURE RISE	80 K MAX.
ROTOR INERTIA	0.074 × 10 <sup>-4</sup> kg·m <sup>2</sup> NOMINAL
INSULATION CLASS	B

NOTE1. SANYO PMM-MD-23221 DRIVE CIRCUIT. (TWO PHASE EXCITATION)  
 E=24 V [DC], I=1.2 A/PHASE.(AVE)  
 NOTE2. MOUNTED ON 100×100×21SPC HEAT SINK, TWO PHASE ENERGIZED  
 AT I=1.2 A/PHASE CONSTANT. MEASURED BY THE CHANGE OF RESISTANCE METHOD.  
 NOTE3. CENTER HOLE ON THE SHAFT END IS NOT ALWAYS MADE.  
 NOTE4. MATCHING CONNECTOR IS NOT ACCESSORY.



CONNECTOR (JST) NOTE 4  
 HOUSING: EHR-6  
 CONTACT: SEH-001T-P0.6

**CONNECTION**

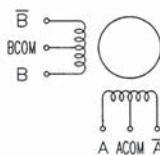

**DIRECTION OF ROTATION**

WHEN MOTOR IS SEQUENCED AS SHOWN IN FIGURE 2. THE SHAFT ROTATION MUST BE CLOCK WISE AS VIEWED FROM SURFACE "B" SIDE.

STEP	BCOM/BCOM	A	B	Ā	B̄
1	+	-	-		
2	+		-	-	
3	+			-	-
4	+	-			-

C E002325B	99-01-25	DESIGNED BY	99-02-16	REV. 001
B E0021293	98-11-06	DESIGNED BY	99-01-26	REV. 002
A NEW DESIGN	98-10-05	DESIGNED BY	99-01-25	REV. 003
山洋電気株式会社		SANYO DENKI CO., LTD.		STEPPING MOTOR
103H5210-0440		REV. 001		REV. 001