

MVT-R043000(L)C	800 x 480	RGB Interface	Aurum TFT Series
Specification			
Version: 1	Date: 09/12/2025		
Revision			
1	09/12/2025	First issue	
		Created By	Checked By
		WE	AB
		Box Quantity	Weight / Display
		---	---

Display Features	
Display Size	4.30"
Resolution	800 x 480
Orientation	Landscape
Appearance	RGB
Supply Voltage	3.3V
Interface	RGB
Brightness	1000cd/m ²
Touchscreen	CTP
Module Size	104.45 x 65.50 x 5.00mm
Operating Temperature	-30°C ~ +85°C
Pinout	40 way FFC
Pitch	0.5mm



Also Available	
Part Number	Description
MVT-R043000(L)C	4.3" RGB TFT, optional Lugs(L), CTP(C), RTP (R)
MVT-H043000(L)C	4.3" HDMI TFT, optional Lugs(L), CTP(C), RTP (R)
MVT-E043000(L)C	4.3" Embedded TFT, optional Lugs(L), CTP(C), RTP (R)

Display Accessories	
Part Number	Description
MDIB-11	HDMI-to-RGB Interface Board
MCIB-41	Aurum HDMI to RGB Carrier Board
MDIB-43	Aurum Embedded HDMI to RGB Board

For full design functionality, please use this specification in conjunction with the HX8264D+HX8664B display driver and FT5726-003+CH571 touch driver specifications.(Provided Separately)



AURUM TFT Display Series Part Number System

MVT - R 0430 00 L C
1 2 3 4 6 7

- 1 = MVT: Midas Versatile TFT
- 2 = Interface R=RGB L=LVDS
H=HDMI E=Embedded
- 3 = Size: Diagonal in inches (0430 = 4.3")
- 4 = Series #: 00, 01, 02 etc
- 5 = Lugs Blank = No lugs
L = Lugs
- 6 = PCAP touch Blank = No touch
C = PCAP touch
R = Resistive touch

DESIGN • MANUFACTURE • SUPPLY



General Data

Display

Feature	Value
Size (inch)	4.30
Resolution (pixels)	800(Horizontal) x 480(Vertical)
Type	TFT/IPS/NORMALLY BLACK/TRANSMISSIVE
Display Size (mm)	104.45 x 65.50 x 2.75
Active Area (mm)	95.04 x 53.86
Interface	24-bit RGB
Connector type	40-way FFC
Connector Pitch (mm)	0.5
Colour Depth	16.7 M
Pixel pitch (mm)	0.1188 x 0.1122
LCD Driver IC	HX8264D+HX8664B
Luminance without touch (cd/m ²)	1250
Viewing Direction (O'clock)	All

Touchscreen

Feature	Value
Type	Capacitive multi-touch
Touch Panel Size (mm)	104.45 x 65.50 x 1.75
Interface	USB or I2C (selectable via link on touch FPC)
Connector type	10-way FFC
Connector Pitch (mm)	0.5
Touch Driver IC	FT5726-003+CH571
ITO Glass thickness (mm)	0.4
Input method	Finger or Stylus
Transparency	≥ 80%
Surface hardness	> 6H
Guaranteed touches	> 35,000,000 times
Input force (g)	≤ 10



Block Diagram

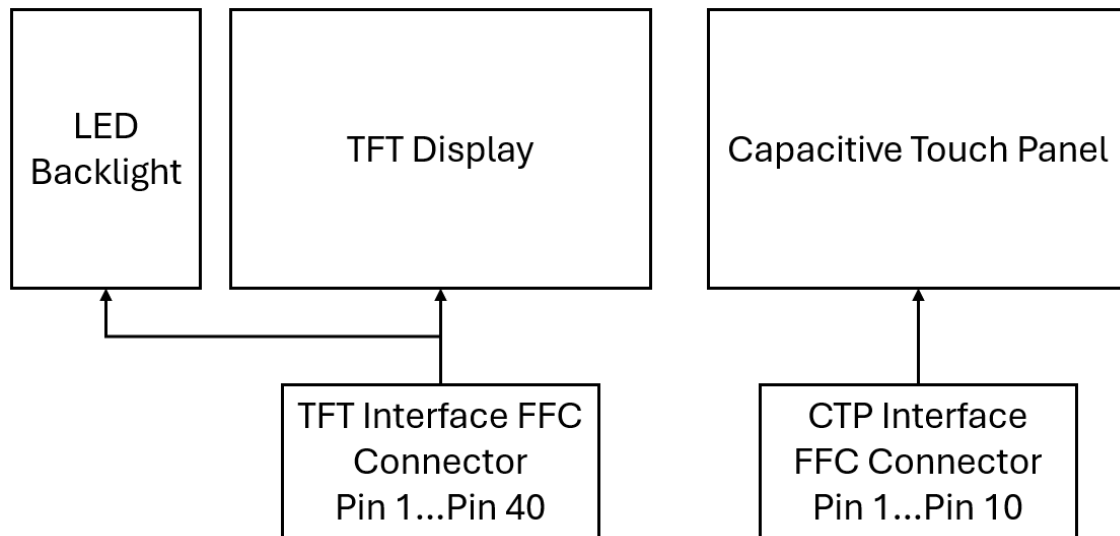

Absolute Maximum Ratings

Parameter	Symbol	Min	Max	Unit
Power Supply Voltage	VDD	-0.5	+5.0	V
Operating temperature	Top	-30	+85	°C
Storage temperature	Tst	-30	+85	°C

Electrical Characteristics

Display

DESIGN • MANUFACTURE • SUPPLY

Item	Symbol	Values			Unit
		Min	Typ.	Max	
Power Supply	VDD	2.7	3.3	3.6	V
Input voltage	Vil	GND	-	0.3 x VDD	V
	Vih	0.7 x VDD	-	VDD	V

Backlight

Item	Symbol	Values			Unit
		Min	Typ.	Max	
Supply Voltage	Vf	14	-	17	V
Supply Current	IL	-	60	-	mA
Power consumption	P	0.84	-	1.02	W
LED lifetime		30000	-	-	H _r



Pin Assignment

Display

Pin No.	Symbol	Description
1	LEDK	Cathode of LED backlight
2	LEDA	Anode of LED backlight
3	GND	Power ground
4	VDD	Power voltage
5	R0	Red data
6	R1	Red data
7	R2	Red data
8	R3	Red data
9	R4	Red data
10	R5	Red data
11	R6	Red data
12	R7	Red data
13	G0	Green data
14	G1	Green data
15	G2	Green data
16	G3	Green data
17	G4	Green data
18	G5	Green data
19	G6	Green data
20	G7	Green data
21	B0	Blue data
22	B1	Blue data
23	B2	Blue data
24	B3	Blue data
25	B4	Blue data
26	B5	Blue data
27	B6	Blue data
28	B7	Blue data
29	GND	Power ground
30	PCLK	Pixel clock
31	/STBYB	Standby mode Active Low
32	HSD	Horizontal sync signal
33	VSD	Vertical sync signal
34	DEN	Data enable
35	NC	No connect
36	GND	Power ground
37	XR(NC)	No connect
38	YD(NC)	No connect
39	XL(NC)	No connect
40	YU(NC)	No connect

Solder Links

Link	Description
I2C Touch	Short R7 and disconnect R6 on top right of Touch FPC
USB Touch	Short R6 and disconnect R7 on top right of Touch FPC



Touch

Pin No.	Symbol	Description
1	VDD_USB 5V	Positive power supply
2	USB_D-	USB interface, D- signal.
3	USB_D+	USB interface, D+ signal.
4	USB_VSS	Negative supply (USB)
5	VSS	Negative supply (I2C)
6	SDA	I2C Serial data input/output
7	SCL	I2C Serial clock input/output
8	VDDT 3.3V	Positive power supply
9	/RST	Global reset input, active low
10	/IN	External Interrupt, output

Optical Characteristics

Item	Symbol	Conditions	Specifications			Unit	
			Min	Typ.	Max		
Luminance	L		-	1000	-	cd/m ²	
Contrast ratio	CR	$\theta=0^\circ$	640	800	-		
Response time	Rising	Tr	25°C	-	30	40	ms
	Falling	Tf					
CIE Colour Coordinate	RED	XR	Normal Viewing Angle	+/-0.02	+/-0.02		0.631
		YR					0.329
	GREEN	XG					0.328
		YG					0.548
	BLUE	XB					0.136
		YB					0.141
	WHITE	XW					0.313
		YW					0.339
Viewing Angle	Hor.	θ_{x+}	CR \geq 10			Degree	70
		θ_{x-}					70
	Ver.	θ_{y+}					70
		θ_{y-}					70



Definition of viewing angle θ_x and θ_y :

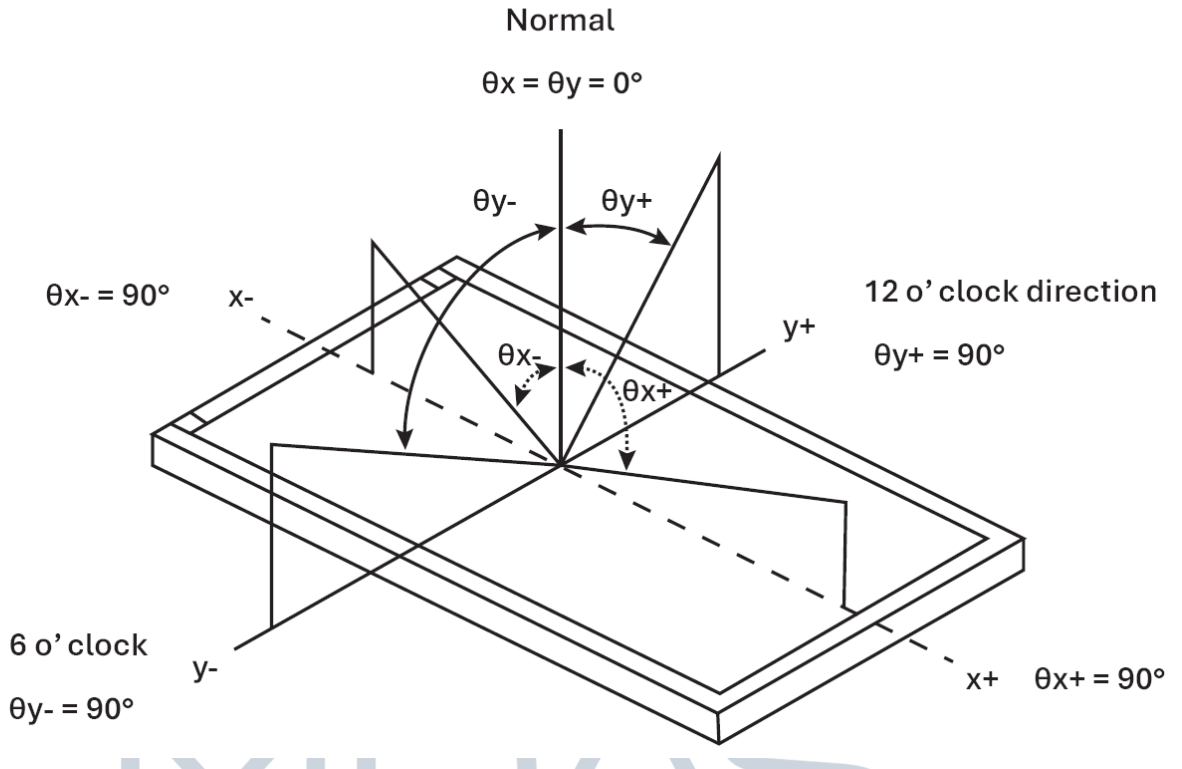

Definition of contrast ratio:

$$CR = \frac{\text{Brightness of non-selected dots (white)}}{\text{Brightness of selected dots (black)}}$$

Definition of response time:

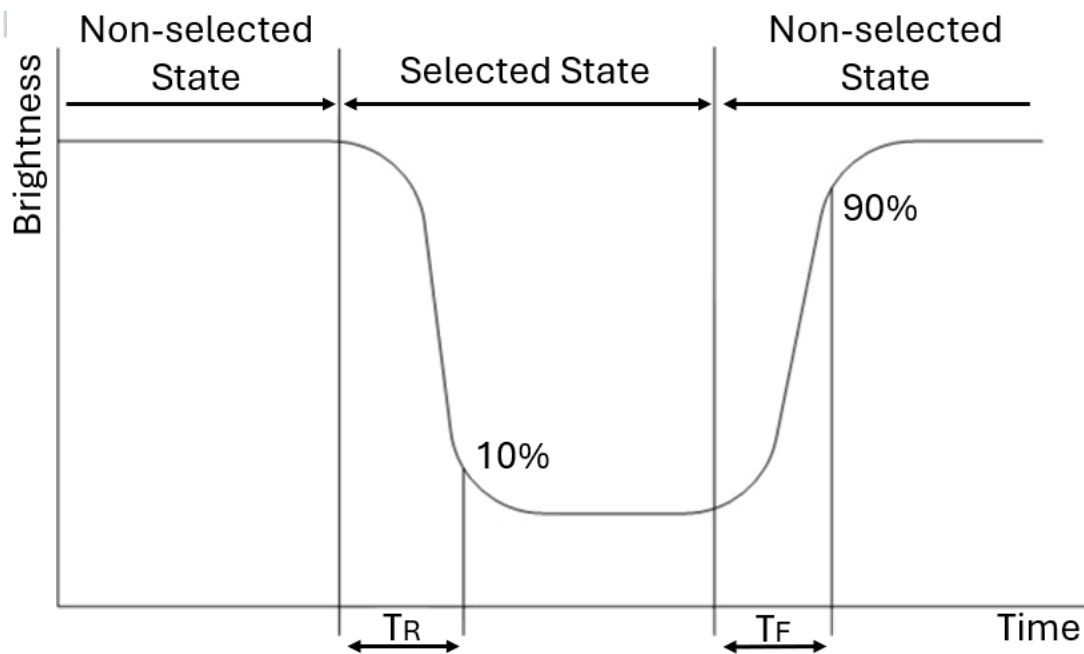

Brightness Test Equipment Setup

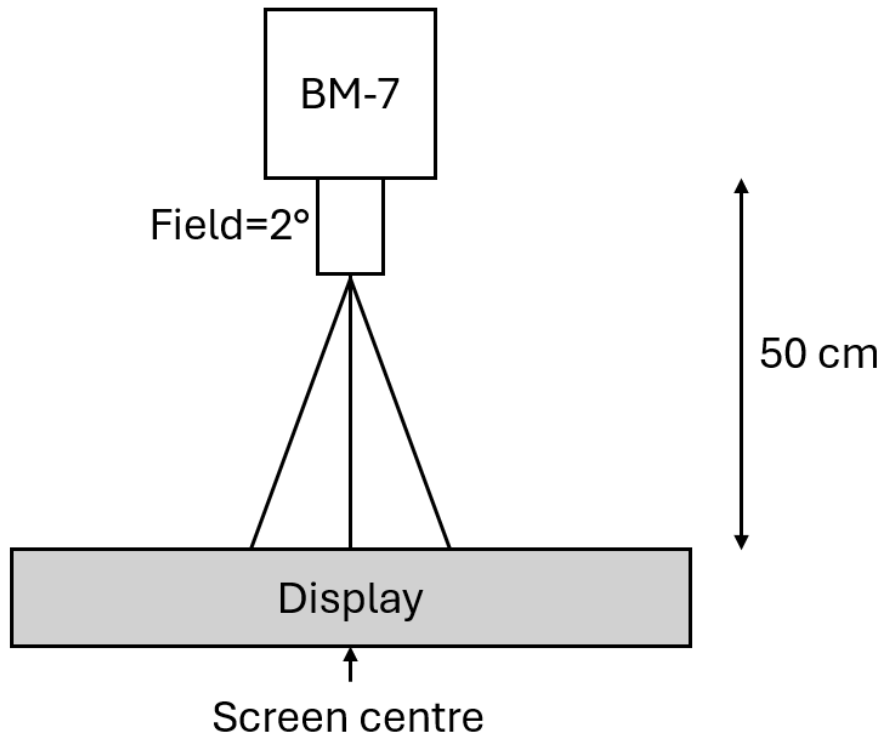

Field = 2° (As measuring "black" image, field = 2° is the best testing condition)

Brightness Test Point Setup

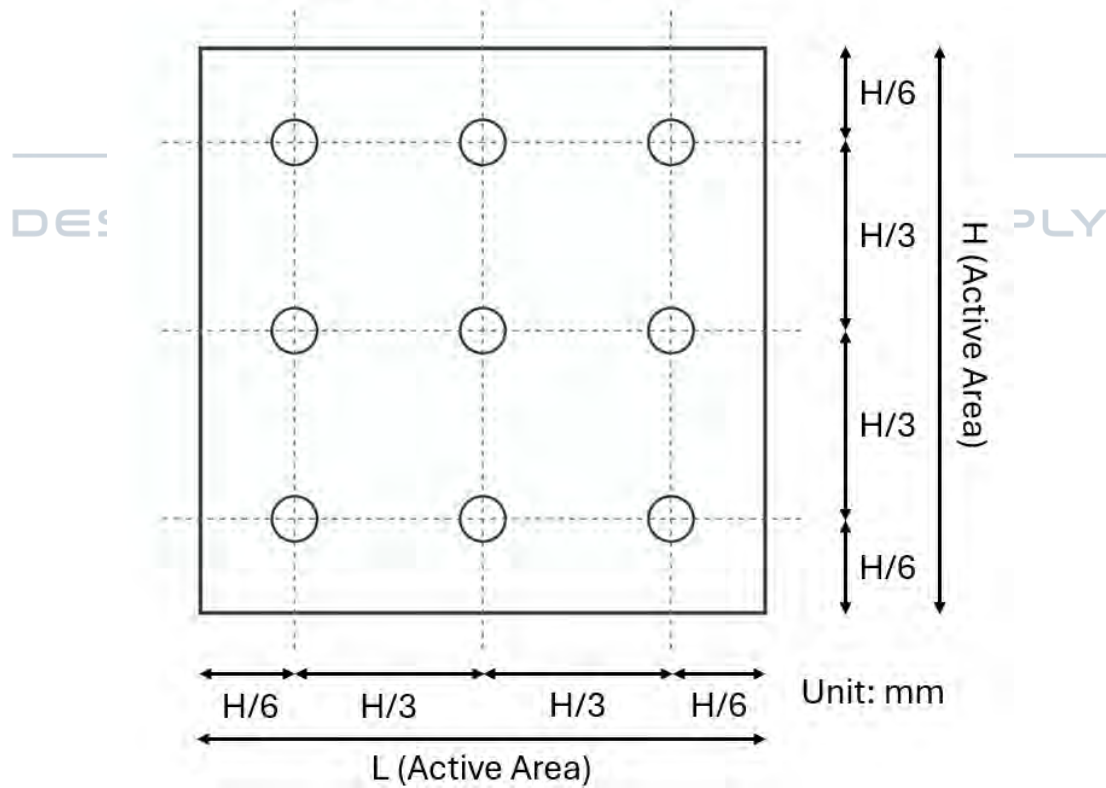

Display Timing Characteristics

SYNC Mode

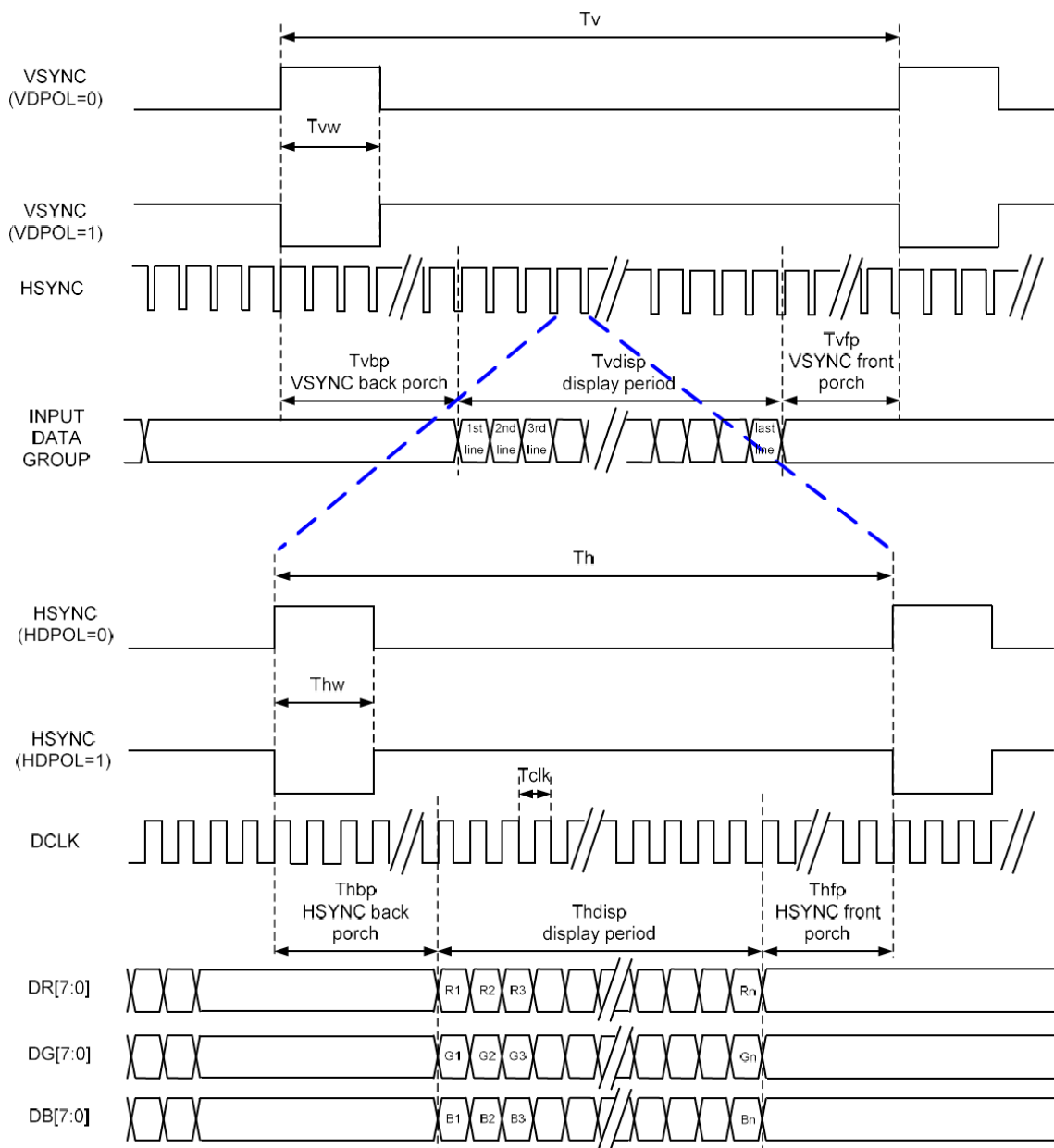

SYNC-DE Mode

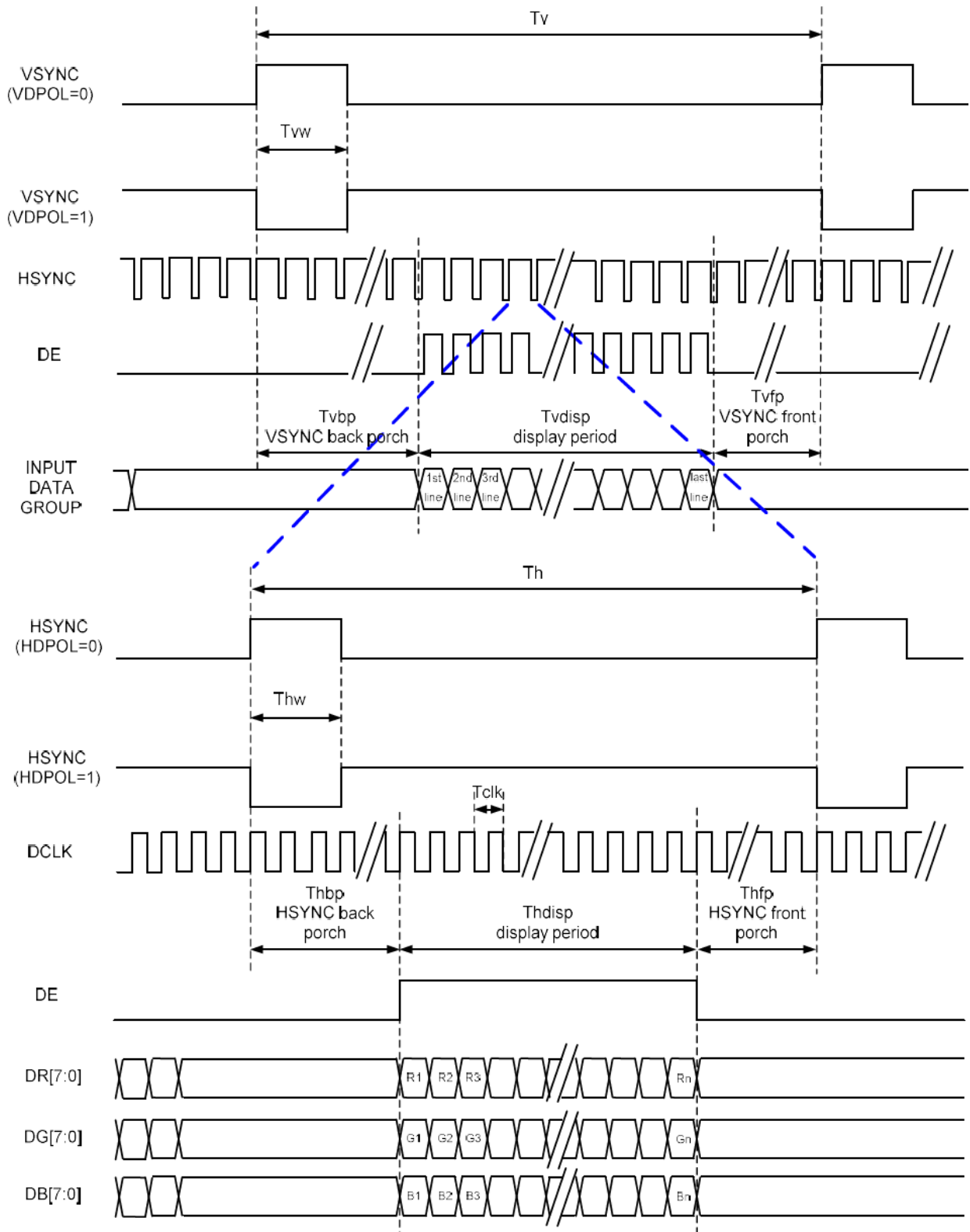

DE Mode

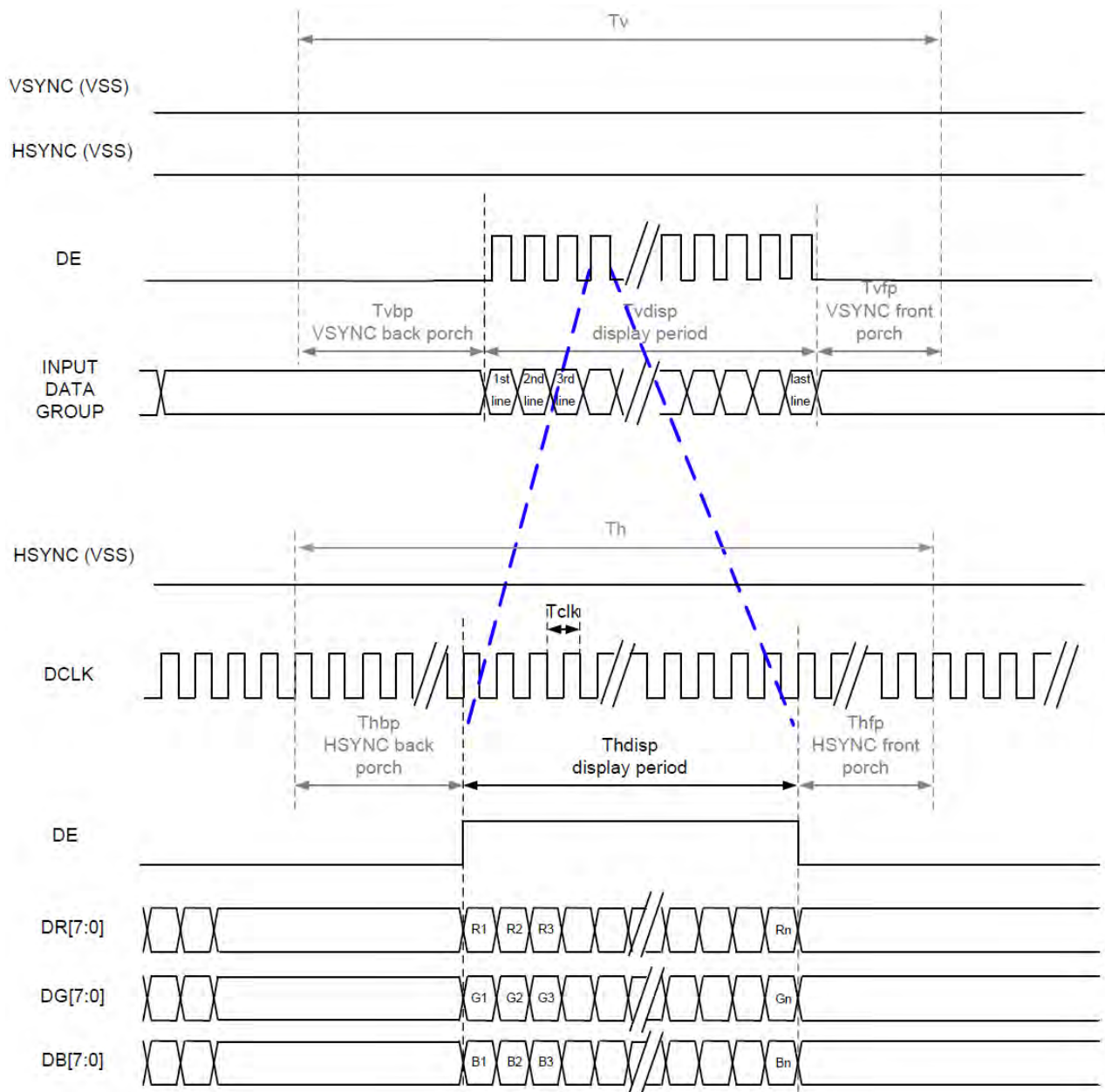

RGB Interface

RGB Mode Selection	DCLK	HSYNC	VSYNC	DE
SYNC – DE Mode	Input	Input	Input	Input
SYNC Mode	Input	Input	Input	GND
DE Mode	Input	GND	GND	Input



Display Timings

Item	Symbol	Min.	Typ.	Max.	Unit	
DCLK Frequency	Fclk	-	30	50	MHz	
HSYNC	Period Time	Th	889	928	1143	DCLK
	Display Area	Thdisp	800			DCLK
	Back Porch	Thbp	-	88	-	DCLK
	Front Porch	Thfp	1	40	255	DCLK
	Pulse Width	Thw	1	48	255	DCLK
VSYNC	Period Time	Tv	513	525	767	HSYNC
	Display Area	Tvdisp	480			HSYNC
	Back Porch	Tvbp	-	32	-	HSYNC
	Front Porch	Tvfp	1	13	255	HSYNC
	Pulse Width	Tvw	3	3	255	HSYNC

Reliability Test

Environmental Item	CONDITIONS	
High Temperature Storage	TA=85°C	96H
Low Temperature Storage	TA=-30°C	96H
High Temperature Operation	TA=85°C	96H
Low Temperature Operation	TA=-30°C	96H
High Temperature and High Humidity Operation	+60°C, 90%RH	96H
Thermal Shock	-30°C → +80°C	0.5H:5CYCLES



Handling Precautions

- The display panel is constructed of glass. Refrain from exposing it to mechanical shock, such as dropping it from a height.
- The display should not be disassembled as this can impact the functionality.
- In the event of damage to the display panel resulting in leakage of the liquid crystal substance, it is imperative not to ingest the substance. If contact occurs with skin or clothing, please wash the affected area thoroughly with soap and water immediately.
- Do not apply excessive force to the display surface or adjoining areas, as this may cause colour tone variations.
- The polariser covering the display surface of the LCD module is soft and easily scratched. Handle this polariser carefully.
- To prevent damage to the elements by static electricity, maintain an optimal work environment.
- Ensure that the body is grounded when handling the LCD module.
- Tools required for assembly, such as soldering irons, must be properly grounded.
- To reduce the generation of static electricity, avoid conducting assembly and other work under dry conditions.
- The LCD module is coated with a film to protect the display surface. Exercise caution when peeling off this protective film, as static electricity may be generated.
- Use only specific solvents, like Isopropyl or Ethyl alcohol, for cleaning the display. Clean with a soft, clean cloth and avoid submerging the display.
- The removal of the protective tape over components may result in damage or cause detachment from their solder pads.
- To minimise potential performance degradation of the LCD modules due to static electricity or other factors, please exercise caution when handling the modules. Avoid touching the following areas:
 - The exposed sections of the printed circuit board
 - The terminal electrode sections.

Assembly Precautions

- Do not make alterations or modifications to the display, including the glass, printed circuit board, components or FFC/FPC unless advised by Midas.
- Solder should only be applied to the specified terminals. For direct solder displays, a hot bar should be used, with 250-300°C for 3-5 seconds.
- The mounting method should consider mechanical stresses placed upon the display.
- Assembling operators should be grounded during the entire process of handling the display. Likewise, any tools, such as soldering irons, should be properly grounded.
- Avoid cleaning solutions from the assembly process, such as solder flux cleaning fluids, from getting onto the display as this can leak into the housing and cause internal damage.
- Assembly should not be conducted under ESD safe conditions to reduce the risk of static electricity.
- Continuous high temperatures during assembly may cause deformation or damage.
- Care should be taken when bending the FFC/FPC, as continuous bends may wear out the circuitry.
- The plating of the FFC/FPC can be worn down by multiple insertions.
- Lead free solder should be used to adhere with RoHS



Operation Precautions

- The maximum ratings of the display should never be exceeded, or functionality cannot be guaranteed.
- Sudden shutdown caused by forced removal of the power supply may cause damage to the electronics of the display.
- Temperature and environment can influence the display and electronics, and the display should be tested by the end customer within expected working conditions to check for satisfactory performance.
- The user should implement external over-current and over-voltage protection.
- Do not apply signals to the logic input if the display is not powered
- A constant current source is recommended for the operation of the backlight. Using a constant voltage source without adequate current limitations can permanently damage the backlights operation.
- If the LCD modules have been operating for a long time showing the same display patterns may remain on the screen as ghost images and a slight contrast irregularity may also appear. Abnormal operating status can be resumed to be normal condition by suspending use for some time. It should be noted that this phenomenon does not adversely affect performance reliability.

Others

- Liquid crystals solidify at low temperature (below the storage temperature range) leading to defective orientation of liquid crystal or the generation of air bubbles (black or white). Air bubbles may also be generated if the module is subjected to a strong shock at a low temperature.
- When storing the LCD modules, avoid exposure to direct sunlight or light from fluorescent lamps. Keep the modules in bags designed to prevent static electricity charging under low temperature and normal humidity conditions (avoid high temperature, high humidity, and temperatures below 0°C). Whenever possible, store the LCD modules in the same packaging as when they were shipped from Midas.
- Midas maintains the right to change the passive components, and the PCB revision without informing the customer with the intent to continue supplying the product with the same or better performance.
- This display is supplied as a component for use within a completed assembly. As such it should be tested within the completed unit for suitability. Performance may vary depending on external components.
- This device will have susceptibility to external noise and interference; care should be taken to isolate or shield the product if necessary. Cables may require additional shielding or shortening.
- The disposal of a display should be handled by qualified industrial waste management and is not for standard waste disposal.
- Midas's warranty liability is strictly confined to the repair and replacement of purchased products. Midas shall not be held liable for any consequential damages.

