

VOFA-...26-T52-M-G14-1C1-...

Control block

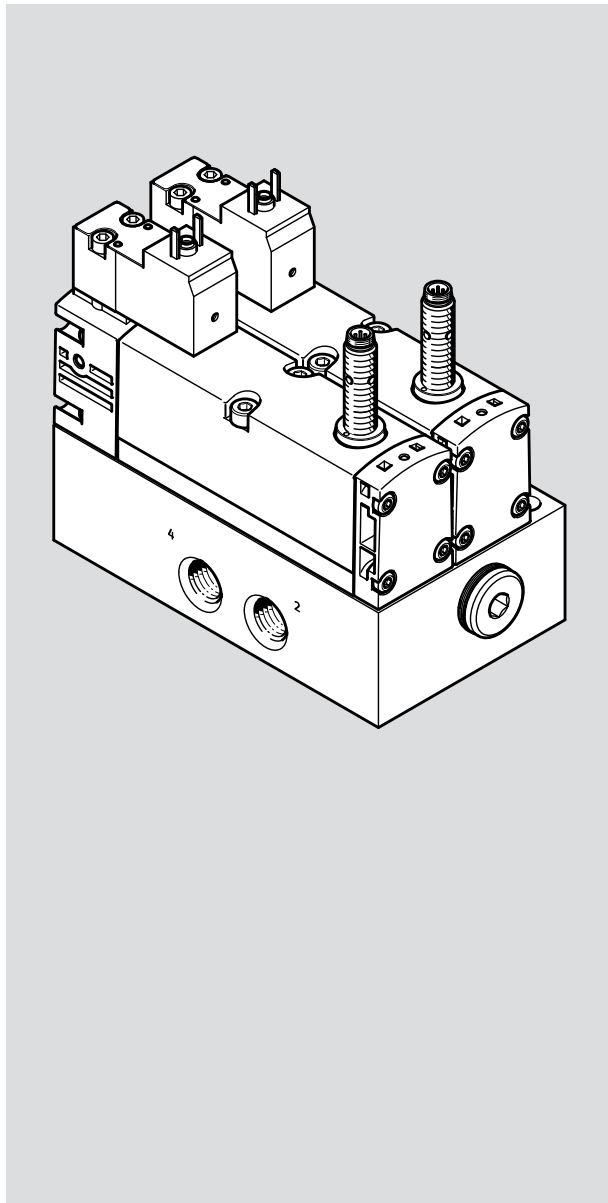

FESTO

Operating instructions



8127558

8127558
2021-09d
[8127560]

Translation of the original instructions

Table of contents

1	Safety	5
1.1	General safety instructions.....	5
1.2	Intended use.....	5
1.3	Foreseeable misuse.....	6
1.4	Safety function in accordance with EN ISO 13849.....	6
2	Requirements for product use	7
2.1	Training of qualified personnel.....	7
2.2	Failures due to a common cause (Common Cause Failure – CCF).....	7
2.3	Diagnostic coverage (DC).....	8
2.4	Range of application and approvals.....	8
2.5	Product identification, versions.....	9
2.5.1	Product labelling.....	9
2.5.2	Manufacturing period.....	9
2.6	Service.....	9
2.7	Specified directives and standards.....	10
3	Product overview	10
4	Connections and display components	11
5	Function and application	13
5.1	Pneumatic linking.....	13
5.2	Electrical linkage.....	14
6	Mounting	15
6.1	Mechanical installation.....	15
6.1.1	Individual connection variant.....	15
6.1.2	Vertical stacking variant.....	16
6.2	Pneumatic installation.....	16
6.2.1	Individual connection variant.....	16
6.2.2	Vertical stacking variant.....	16
6.3	Electrical installation.....	17
7	Commissioning	17
7.1	Prior to commissioning.....	17
7.2	Switching characteristics during switch-on.....	18
7.3	Switching characteristics at switch-off.....	18
7.4	Function test.....	19
8	Fault clearance	22
8.1	External influences.....	22
8.2	Internal influences.....	23
9	Operation and use	23
10	Maintenance and care	23
11	Modification, disassembly and repair	23
11.1	Conversion and disassembly.....	23
11.2	Repair.....	23
11.3	Decommissioning and disposal.....	25

12	Spare parts and accessories.....	25
13	Technical data.....	26

1 Safety

1.1 General safety instructions

WARNING

Risk of injury by crushing and impact

If solenoid valves are disconnected from the power supply when energised, the movable parts of the drive components (cylinders, motors, etc.) can execute uncontrolled movements if they are subjected to external forces.

- Move the drive components to a safe position. Only then carry out work on the electrical equipment.

NOTICE

Loss of safety functions

If measures for managing “common cause failures” (CCF) are not observed, or if potentially faulty statuses are not discovered as a result of inadequate testing, the safety function of the control block may be impaired.

- Observe the measures for the control of “common cause failures” (CCF) → 2.2 Failures due to a common cause (Common Cause Failure – CCF).
- Make sure the degree of diagnostic coverage (DC) is reached → 2 Requirements for product use and → 13 Technical data.

NOTICE

Loss of the safety function

Non-compliance with the technical data can lead to loss of the safety function.

- Observe the technical data → 13 Technical data.

NOTICE

Loss of the safety function

Only use the product if it is in its original condition and in perfect working order.

1.2 Intended use

The control block is designed exclusively for reversing double-acting pneumatic drives and can be used to implement the following safety functions:

- Safe reversal of a hazardous movement, provided the reversing motion itself will not result in further hazards.

Reversing means the reversal of a hazardous movement (corresponding to the safe direction of movement). Reversing does not correspond to reaching the cylinder end position (because potential failure modes must be taken into account). This corresponds to the “safe direction of movement” safety function (English: Safe Direction, SDI) within the limits of the control block.

- Protection against unexpected start-up (EN ISO 14118)

This corresponds to the “prevention of unexpected start-up” safety function (English: Prevention of Unexpected Start-up, PUS) within the limits of the control block.

The product is intended for installation in machines or automated systems and may only be used as follows:

- Use only in an industrial environment: outside industrial environments, e.g. in mixed commercial and residential areas, action to suppress interference may be required.
- Use only in standard operation: this also includes downtime, set-up and service operation, as well as emergency operation.
- Use only within the limits of the product as defined by the technical data → 13 Technical data
- Use only in its original status without unauthorised modifications (exceptions → 11 Modification, disassembly and repair) and in perfect technical condition

1.3 Foreseeable misuse

NOTICE

In the event of damage caused by unauthorised manipulation or use other than the intended use, the guarantee will be invalidated and the manufacturer will not be liable for damages.

The following examples of foreseeable misuse are among those not approved as intended use:

- outdoor use
- bypass of the safety function
- omission of evaluation of the sensor signal change for each valve switching procedure as well as a comparable measure for diagnostics
- use in reversible operation (using supply air instead of exhaust air, and vice versa)
- operating mode with low demand mode according to IEC 61508
- Vacuum operation

1.4 Safety function in accordance with EN ISO 13849

The control block has been developed and manufactured in accordance with the corresponding basic and proven safety principles of EN ISO 13849-2. The control block exhibits structural properties that enable Performance Level e/category 4 to be achieved for implementation of the safety function. The operator is responsible for specification of the safety function. The “safe reversing” safety function depends on the following factors:

- operating parameters of the entire control chain, including the drive and all moving masses that have an influence on the reaction time of the drive.
- switching times when switched off → 7.3 Switching characteristics at switch-off

The achievable safety level depends on the other components used to implement a safety function.

The following requirements apply to the manager:

- The specifications for mounting and the operating conditions in these operating instructions must be observed.
- For use in higher categories (2 to 4), the requirements of EN ISO 13849-1 (with regard to structure, DC, CCF and systematic failures, behaviour under error conditions, ambient conditions) must be taken into account.
- The solenoid valves must be switched at least once per week to ensure intended use.
- The basic and proven safety principles of EN 13849-2 relating to the implementation and operation of the component must be met.
- When using this product in machines or systems subject to specific C standards, the requirements specified in these standards must be observed.

- The user is responsible for coordinating all applicable safety regulations and rules with the competent authority and for compliance with regulations and rules.
- Failure of the working pressure supply at port (1) of the control block may result in failure of the safety functions. The user must evaluate whether additional measures are required to safeguard the working pressure supply depending on the application.
- If the control block is used in pneumatic presses, the standard "ISO 16092-4 Machine Tools – Safety of Presses – Part 4: Pneumatic Presses" should be taken into account.

2 Requirements for product use

- The operating instructions should be available to the design engineer and installer of the machine or system in which this product will be used.
- Keep the operating instructions for the entire product lifecycle.
- Take into consideration the legal regulations for the location:
 - instructions and standards
 - regulations of the testing organisations and insurers
 - national specifications

2.1 Training of qualified personnel

Mounting, installation, commissioning, servicing, repair and decommissioning may only be performed by qualified personnel who are familiar with the following tasks and information:

- installation and operation of electrical and pneumatic control systems
- applicable instructions for operating safety-related systems
- applicable instructions for accident prevention and occupational safety
- the documentation for the product:

NOTICE

Only authorised and appropriately trained personnel are permitted to work on safety-related systems.

2.2 Failures due to a common cause (Common Cause Failure – CCF)

Common cause failures cause the failure of the safety function, as both channels in a 2-channel system fail simultaneously in these cases.

The following measures ensure that common cause failures are prevented:

- compliance with the compressed air quality, in particular avoidance of flash rust particles, e.g. caused by servicing work.
- compliance with the residual oil content (maximum 0.1mg/m³ when using ester-based oils, which, for example, are contained in compressor oil).
- compliance with the operating and control pressure limits, if necessary by installation of a pressure-relief valve.
- compliance with the temperature range.
- compliance with the permissible values for vibration and shock stress.
- longitudinal valve axes preferably arranged vertically to the main direction of vibration.
- compliance with the maximum permissible test pulse length when used at timed safety outputs.
- compliance with the maximum permissible strength of external magnetic fields.

NOTICE

Loss of the safety function

Non-compliance with the technical data can lead to loss of the safety function.

- Observe the technical data → 13 Technical data.

2.3 Diagnostic coverage (DC)

A diagnostic coverage of 99% can be achieved by appropriate integration of the control block into the control chain and corresponding test equipment. The change of the corresponding sensor signal in the machine control system must be queried every time a valve is actuated. If a fault is detected by the test equipment (e.g. missing sensor signal), appropriate measures must be taken to maintain the safety level → 8 Fault clearance.

Of particular note here are the following failure modes:

- failure of the solenoid valve V2 to switch back completely. This fault can result in an incomplete reversal.
- failure of the solenoid valve V1 to switch back completely. This fault can result in the pressure applied at port (4) not being dissipated.
- Simultaneous incomplete switching back of both solenoid valves (V1 and V2): this fault can result in a failure of the safety function.

2.4 Range of application and approvals

This product is a safety device as defined in the EC Machinery Directive 2006/42/EC and carries the CE marking.



Fig.1

Safety-oriented standards and test values with which the product is compliant and fulfils can be found in → 13 Technical data. The EC directives and standards relevant to the product can be found in the declaration of conformity.



Declaration of conformity for this product → www.festo.com/sp.

2.5 Product identification, versions

2.5.1 Product labelling

Product labelling (example)		Meaning
1	VOFA-L26-T52-M- G14-1C1-APP	1 order reference
2	569819 E7XX p max: 10 bar/ 145 psi	2 part number
		3 serial number with manufacturing period (encoded → 2.5.2 Manufacturing period)
		4 maximum operating pressure
		5 CE marking

Tab. 1: Product labelling (rating plate) of the product

2.5.2 Manufacturing period

In the product labelling, the first 2 characters of the serial number indicate the manufacturing period in encrypted form → Tab. 1 Product labelling (rating plate) of the product. The letter specifies the manufacturing year and the character after it (number or letter) indicates the manufacturing month.

Manufacturing year					
H=2016	J=2017	K=2018	L=2019	M=2020	N=2021
P=2022	R=2023	S=2024	T=2025	U=2026	V=...

Tab. 2: Manufacturing year

Manufacturing month	
1	January
3	March
5	May
7	July
9	September
N	November
2	February
4	April
6	June
8	August
O	October
D	December

Tab. 3: Manufacturing month

2.6 Service

Please consult your regional Festo contact if you have any technical queries → www.festo.com.

2.7 Specified directives and standards

Version	
2004/108/EC:2004-12-15	IEC 60947-5-2:2007-10
2006/42/EC:2006-05-17	IEC 61076-2-104:2014-09
EN ISO 13849-1:2015-12	IEC 61508:2010-04
EN ISO 13849-2:2012-10	ISO 8573-1:2010-04
IEC 60068-2-6:2007-12	EN ISO 14118:2018-02
IEC 60068-2-27:2008-02	EN 175301-803:2006-08
IEC 60204-1:2016-10	VDE 0580:2011-11
ISO 16092-4:2019-11	–

Tab. 4: Directives and standards specified in the document

3 Product overview

The control block has been developed and manufactured subject to careful application of the relevant standards and directives as well as the approved technical rules. The safety function is not guaranteed if the control block is used outside the scope of its intended use → 1.2 Intended use. This can result in hazards for people.

The control block consists of a manifold sub-base and 2 solenoid valves and is supplied fully assembled. It is offered in two product variants → Tab. 5 Control block overview .

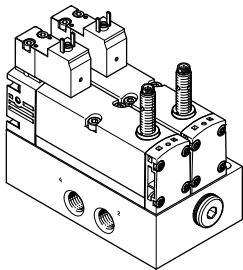
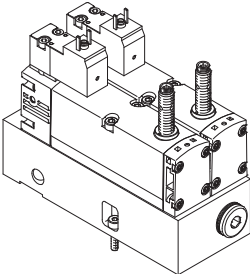
Control block	Individual connection variant	Vertical stacking variant for VTSA valve terminal
Product image		
Order reference	VOFA-L26-T52-M-G14-1C1-...	VOFA-B26-T52-M-G14-1C1-...
Electrical interface of the solenoid valves	Plug, design in accordance with EN 175301-803, type C, without PE conductor	
Piston position sensing	by inductive PNP or NPN proximity switches, size M8x1, with plug connection in accordance with IEC 61076-2-104	

Tab. 5: Control block overview

4 Connections and display components

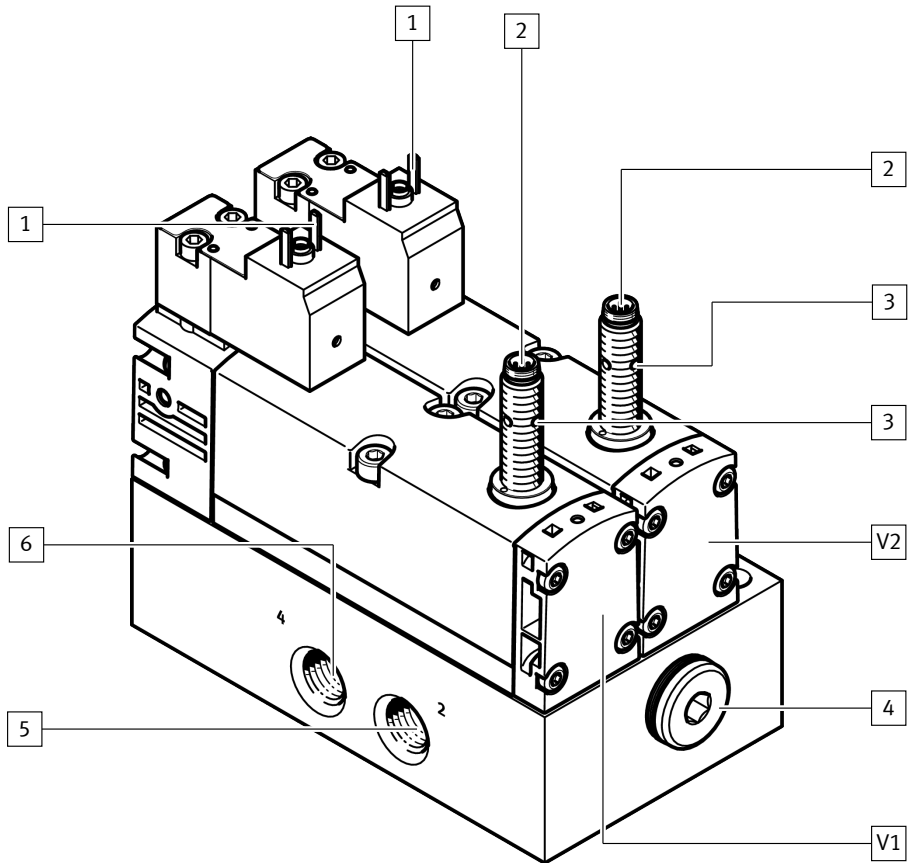

Fig. 2: Pneumatic and electrical connections and display components on the control block (here individual connection variant)

- | | |
|---|---|
| <p>1 Contacts of the solenoid coils</p> <p>2 Contacts of the proximity switches</p> <p>3 Yellow status display LEDs of the proximity switches (four on the periphery)</p> <p>4 Pneumatic port for pressure indicator at port (2) via an optional pressure gauge, size G1/4"</p> | <p>5 Pneumatic port (2) (only with individual connection variant at side), size G1/4"</p> <p>6 Pneumatic port (4) (only with individual connection variant at side), size G1/4"</p> <p>V1 Valve "V1"</p> <p>V2 Valve "V2"</p> |
|---|---|

Without illustration: pneumatic ports (1), (3) and (5) on the opposite side of the control block, size G1/4".



Explanations of the valve designations "V1" and "V2" → 5 Function and application

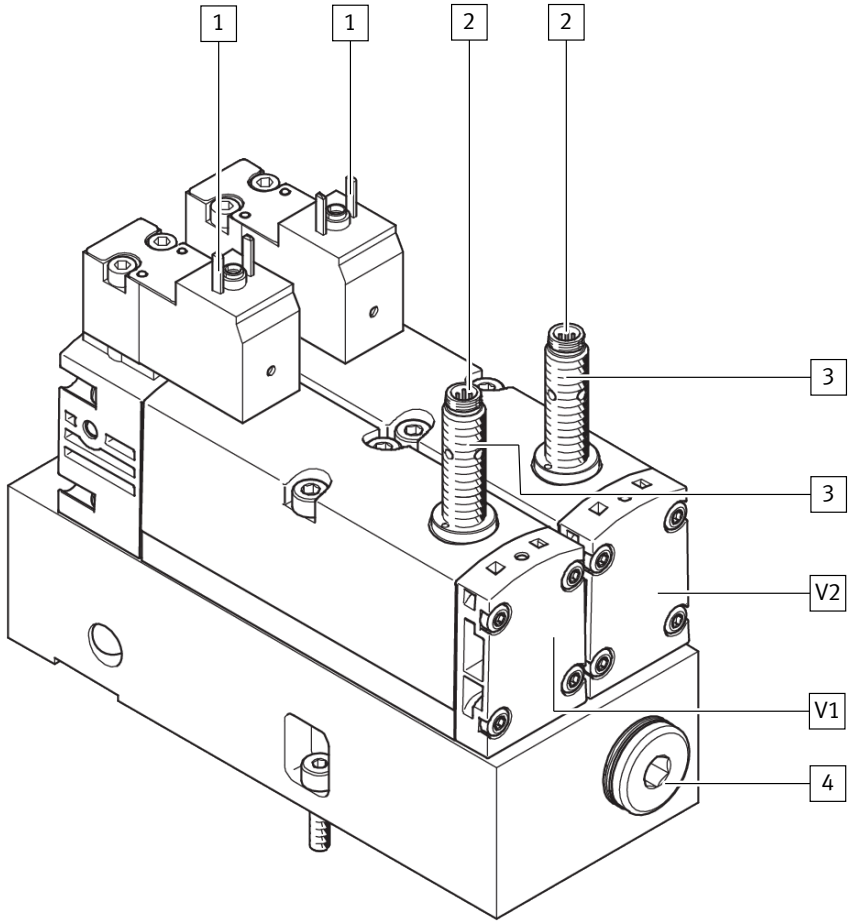

Fig. 3: Pneumatic and electrical connections and display components on the control block (here: vertical stacking variant)

- | | |
|---|---|
| <ul style="list-style-type: none"> 1 Contacts of the solenoid coils 2 Contacts of the proximity switches 3 Yellow status display LEDs of the proximity switches (four on the periphery) | <ul style="list-style-type: none"> 4 Pneumatic port for pressure indicator at port (2) via an optional pressure gauge, size G1/4" V1 Valve "V1" V2 Valve "V2" |
|---|---|



Explanations of the valve designations “V1” and “V2” → 5 Function and application

5 Function and application

5.1 Pneumatic linking

The safety function is achieved by 2-channel pneumatic linkage of 2 monostable 5/2-way solenoid valves within the control block circuit symbol → Tab. 15 Circuit symbols of the control block:

- Port (4) is only pressurised if both solenoid valves are switched to switching position (14).
- Port (2) is always fed with compressed air if at least one of the two solenoid valves is in normal position. The valves are reset via a mechanical spring.

The sensing of proximity switches (E1 and E2) at the solenoid valves (V1 and V2) enable monitoring of the switching operation of the solenoid valves. This is done by a logic operation of the control signal and the signal change of the proximity switch to check whether the piston slides of the solenoid valves are reaching or leaving the normal position (expected action). The piston slides of the solenoid valves are designed to prevent pneumatic short circuits between ports (2) and (4) (overlap).

The pneumatic port example (→ Fig. 4) shows the linkage of the control block. It contains an upstream combination (series connection) of a pressure regulator and pressure-relief valve. The latter serves to protect the pressure-relief function of the pressure regulator.

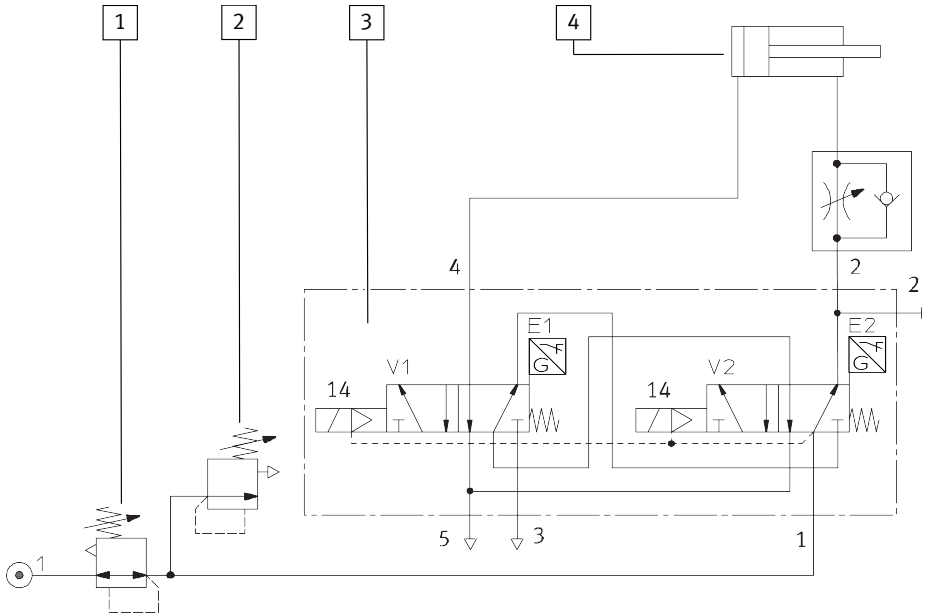

Fig. 4: Example of a 2-channel pneumatic linkage of the control block (here: individual connection variant)

- | | |
|--------------------------------|------------------------|
| 1 Pressure regulator | 3 Control block |
| 2 Pressure-relief valve | 4 Actuator |

5.2 Electrical linkage

NOTICE

Electrical control of the solenoid valves must satisfy the requirements of the specified category: it can be implemented with a common safe electrical output or 2 independent safe channels.

In the electrical connection example (➔ Fig. 5), the safety function is triggered by a 2-pin emergency stop button (S1, with locking function) on a safety switching device. The safety switching device disconnects the power supply of both solenoid valves (V1, V2) and reports the release to the PLC. The PLC records the feedback signal of the safety switching device and the two sensor signals of the control block. As a result, the solenoid valves can be tested both in standard operation and in safety conditions.

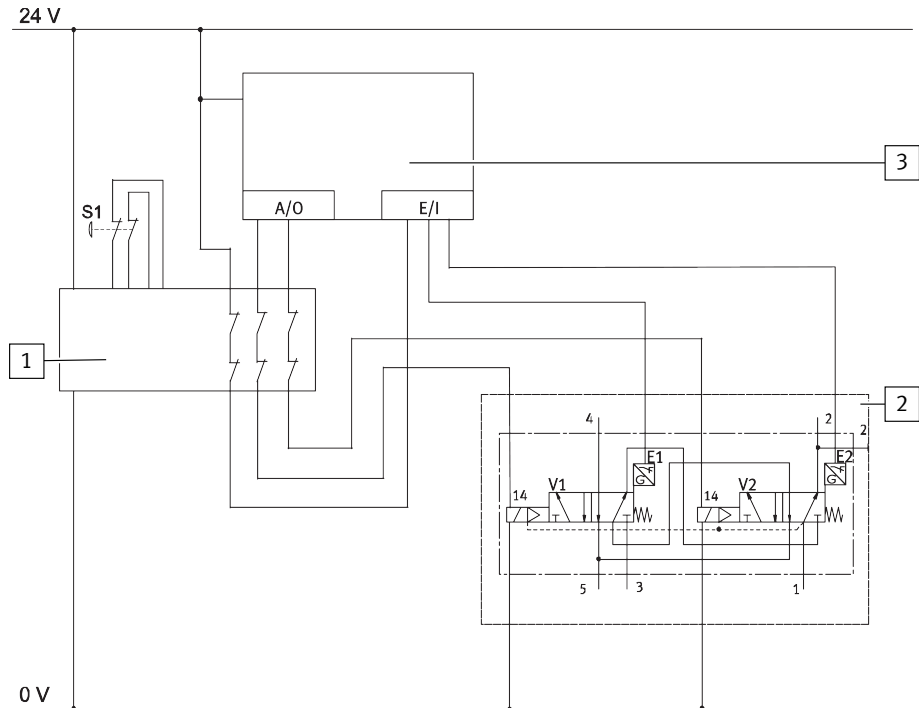

Fig. 5: Example of a 2-channel electrical linkage of the control block with diagnostic test equipment

- 1 Safety relay unit
- 2 Control block
- 3 Programmable logic controller (PLC)

This circuit is an example and can be replaced by other circuits, as long as both solenoid valves are controlled according to the requirements of the required category and the signals of both proximity switches (E1, E2) are evaluated.

6 Mounting

⚠ WARNING

Risk of injury due to particles in the exhaust air

Exhaust air that flows out at high speed can carry particles that may injure people in the vicinity.

- Make sure that the exhaust air escapes into areas where people are not present during operation.

6.1 Mechanical installation

6.1.1 Individual connection variant

Mount as follows:

1. Ensure the control block is earthed by mounting toothed discs between the screw head and control block.
2. Fasten the control block using the intended drilled holes → Fig. 6. Refer to the hole pattern for the required dimensions.

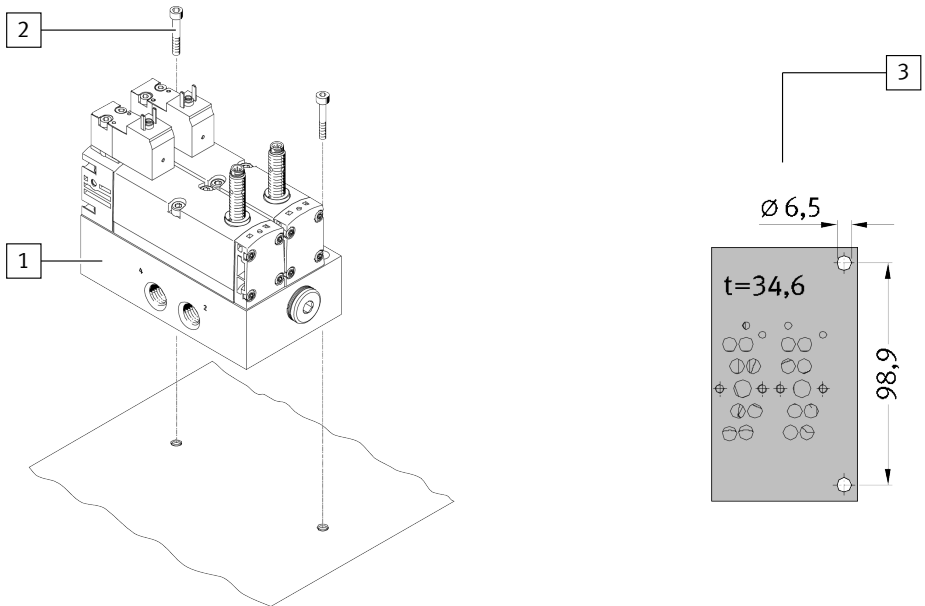

Fig. 6: Attachment/mounting of the control block, individual connection variant

- | | |
|--|---|
| <p>1 Control block</p> <p>2 Screw with toothed disc (M6, not included in delivery)</p> | <p>3 Hole pattern (t corresponds to the height of the block)</p> |
|--|---|

6.1.2 Vertical stacking variant

The vertical stacking variant is supplied pre-assembled from the factory together with the VTSA valve terminal. No other assembly steps are required before installation. Information on the H-rail or wall mounting of the valve terminal can be found in the description "Pneumatic VTSA-...", type P.BE-VTSA-44-...

6.2 Pneumatic installation

NOTICE

- Before mounting: remove particles in the supply lines by appropriate measures. This protects the control block from premature failure and higher wear.
- Observe the specifications for compressed air quality → 13 Technical data.
- Use ducted exhaust air or silencers at connection (3) and (5).
- Do not block silencer or ports (3) and (5).
- Do not use a sintered-metal silencer.



Accessories for tubing connections → www.festo.com/catalogue.

6.2.1 Individual connection variant

NOTICE

- Use type UO-1/4 silencer (→ 12 Spare parts and accessories) or a silencer with comparable properties.
- Make sure the exhaust is unobstructed. When using the type UO-1/4 silencer maintain clearance of at least 15 mm in an axial direction of the silencer.

Mount the ports (1), (2) and (4) as follows:

- Use fittings with connecting thread G1/4" to connect the tubing to the ports for operating pressure (1) and working pressure (2) and (4).

Mount the ports (3) and (5) as follows:

- Screw silencer into ports (3) and (5) with connecting thread G1/4".
- If a silencer is not used:
ensure unobstructed exhaust into areas where people are not present during operation.

6.2.2 Vertical stacking variant

NOTICE

- Operate the control block on the valve terminal in a separate pressure zone for channels (3) and (5) to minimise the risk of back pressures.

Mount the ports (2) and (4) as follows:

- Use fittings with connecting thread G1/4" to connect the tubing to the ports for working pressure (2) and (4).

6.3 Electrical installation

⚠ WARNING

Electric voltage

Injury caused by electric shock, damage to machine and to system

- Use only PELV circuits in accordance with IEC 60204-1 (protective extra-low voltage (PELV)) for the electrical power supply.
- Observe the general requirements of IEC 60204-1 for PELV circuits.
- Use only voltage sources that guarantee reliable electrical isolation of the operating and load voltage in accordance with IEC 60204-1.

Mount as follows:

- Connect solenoid coils.
- Connect the proximity switch → Tab. 6 Contact assignment of the proximity switch with 3-pin M8 plug in accordance with IEC 61076-2-104.

Pin allocation	Pin	Plug pattern (Top view of device)
Supply voltage 24 V DC	1	
Output (N/C contact)	4	
Connection 0 V	3	

Tab. 6: Contact assignment of the proximity switch with 3-pin M8 plug in accordance with IEC 61076-2-104

i

Accessories for connecting solenoid coils and proximity switches → www.festo.com/catalogue.

7 Commissioning

NOTICE

Electrical safety outputs of safety relay units can be parameterised so that they emit test pulses. The outputs are thereby tested at regular intervals. These test pulses can result in maloperation of the control block. The safety function is then no longer guaranteed.

- Make sure that the length of the test pulses from safety relay units does not exceed the maximum permissible test pulse length of the solenoid valves → 13 Technical data.

7.1 Prior to commissioning

- Switch off the power supply before connecting or disconnecting plugs (danger of functional damage).
- Commission only control blocks that are fully mounted and wired.

7.2 Switching characteristics during switch-on

→ Fig. 7 shows the pneumatic and electric switch-on characteristics at the control block with PNP proximity switches and without resistive load. Query (resistive load) of the proximity switch enables the switching times to be extended by a maximum of 2 ms. When using NPN proximity switches, the signal characteristics are reversed, i.e. rising instead of falling.

Process during switch-on

Both coils are energised at time $t = 0$. After approx. 11 ms, the proximity switches signal that the solenoid valves have switched from normal position, and after a total of approx. 22 ms the pressurisation changes from port (2) to (4). Additional switching times → 13 Technical data.

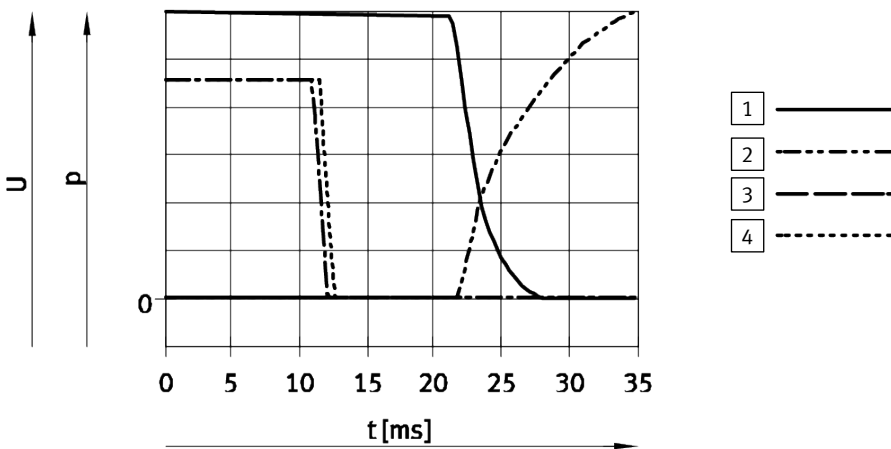

Fig. 7: Graph with signal sequence at switch-on of the control block (graph shows measurements with the PNP proximity switch at an operating pressure of 6 bar without resistive load.)

- | | |
|------------------------|---|
| 1 Pressure at port (2) | 3 Signal voltage at proximity switch E1 |
| 2 Pressure at port (4) | 4 Signal voltage at proximity switch E2 |

NOTICE

The switching times shown in → Fig. 7 only apply for 6 bar and were determined using pressure transducers at ports (2) and (4). Switching times for 3 bar and 10 bar → 13 Technical data.

NOTICE

Switching times during switch-on are not relevant for the safety function.

7.3 Switching characteristics at switch-off

→ Fig. 8 shows the pneumatic and electric switch-off characteristics at the control block with PNP proximity switches and without resistive load. Query (resistive load) of the proximity switch enables the switching times to be extended by a maximum of 2 ms. When using NPN proximity switches, the signal characteristics are reversed, i.e. falling instead of rising.

Process during switch-off

Voltage to both coils is switched off at time $t = 0$. After approx. 56 ms or 59 ms, the pressurisation changes from port (4) to (2) and the proximity switches signal that the piston slides of the solenoid valves have reached the normal position after a total of approx. 60 ms. Additional switching times → 13 Technical data.

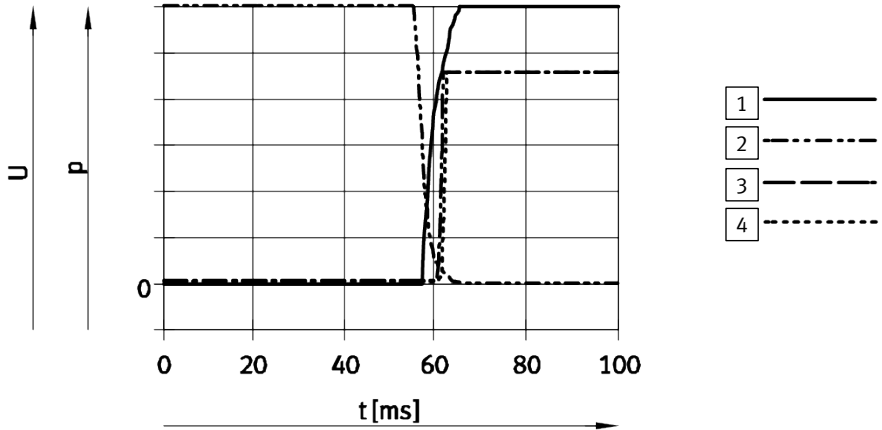

Fig. 8: Graph with signal sequence at switch-off of the control block (graph shows measurements with the PNP proximity switch at an operating pressure of 6 bar without resistive load.)

- | | |
|------------------------|---|
| 1 Pressure at port (2) | 3 Signal voltage at proximity switch E1 |
| 2 Pressure at port (4) | 4 Signal voltage at proximity switch E2 |

NOTICE

The switching times shown in → Fig. 8 only apply for 6 bar and were determined using pressure transducers at ports (2) and (4). Switching times for 3 bar and 10 bar → 13 Technical data.

NOTICE

Switching times during switch-off are relevant for the “safe reversing” safety function. The switching time establishes the earliest time when a change of signal of the proximity switches can take place. Due to wear, it can change with an increasing number of switching cycles.

- After every installation, check the time until change of pneumatic actuation.
- Determine the length of time from switching power off the coils until the signal changes of the proximity switches and adjust the monitoring time of the PLC accordingly.

7.4 Function test

Requirements

- Electrical installation at the control block must be completed.
- Pneumatic installation at the control block must be completed.

Action sequence

1. Switch on operating pressure.
2. Apply operating voltage.
3. To check all possible switching position combinations of the two 5/2-way solenoid valves V1 and V2 of the control block: evaluate signals of proximity switches E1 and E2 (here: PNP proximity switches) with the following step sequences (→ Fig. 9 ... → Fig. 11).

Pressurisation of the ports (2) and (4) is symbolised through p2 and p4. The separate periods for the step sequences depend on the specific application and are not considered here.

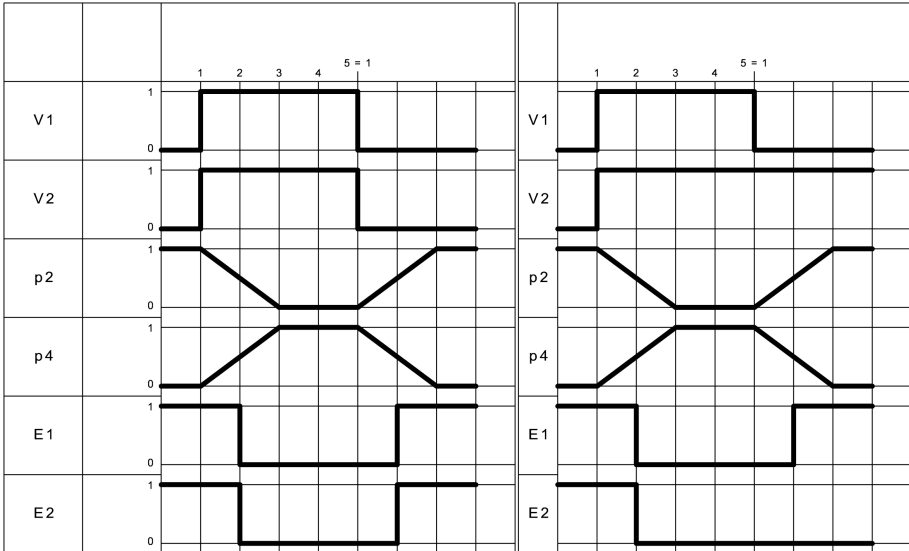

Fig. 9: Function test, steps 1 and 2

Commissioning

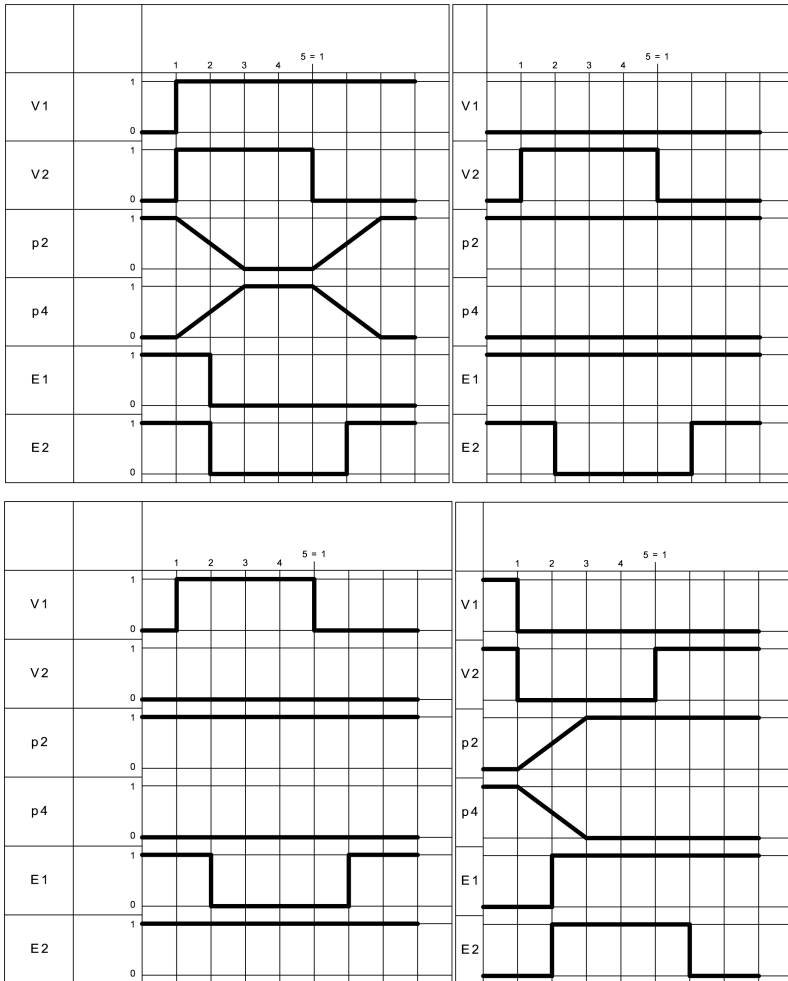

Fig. 10: Function test, steps 3 to 6

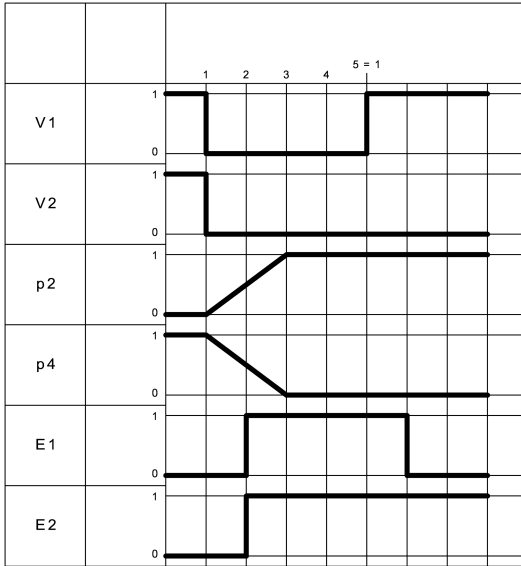

Fig. 11: Function test, step 7

Result

If malfunctions occur: → 8 Fault clearance.

If the function test has been completed as expected and without any problems: the control block can now be operated safely → 9 Operation and use.

8 Fault clearance

If malfunctions are noticed on the product or its function, suitable measures to maintain the safety level must be taken.

If an error or failure is recognised, a check must be made whether this is based on external or internal influences so that corresponding measures for fault clearance can be introduced.

Check control block for correct switching characteristics at the following times:

- during commissioning or after repair/fault clearance
- after interruption of the signal lines of the proximity switches
- after interruption of the signal lines of the solenoid coils

8.1 External influences

Exclude external influences that can cause an error message as follows:

1. Check compressed air supply and compare it with the technical data, e.g. pressure level/filtration, → 13 Technical data.
2. Check the power supply and adjust it in accordance with the technical data → 13 Technical data.
3. Check the overall installation: solenoid coil control and proximity switches → 5 Function and application, pneumatic ports and tubing lines.
4. Carry out a function test to ensure that control block operates properly → 7 Commissioning.

8.2 Internal influences

Exclude external influences → 8.1 External influences.

Exclude as follows internal influences that can cause an error message:

1. Replace defective solenoid valves, if necessary → 11 Modification, disassembly and repair.
2. Carry out a function test to ensure that control block operates properly → 7 Commissioning.
3. If the malfunction continues: replace the complete control block.
4. Carry out a function test to ensure that control block operates properly → 7 Commissioning.

9 Operation and use

- Have specialised personnel instruct end users of the product.
- To maintain the functionality of the product, switch both valves at least once per week.
- Check the condition of the sealing wax of the proximity switches at least once a week.

10 Maintenance and care

- Once you have selected a medium, e.g. unlubricated compressed air, continue using it for the entire service life of the product.
- Switch off the following energy sources before cleaning the exterior:
 - Operating voltage
 - Compressed air
- If the control block is dirty, clean it with a soft cloth. Permissible cleaning media include: detergent at maximum 50 °C or other non-abrasive media.
- When using a silencer other than the one recommended:
clean regularly to prevent clogging.

11 Modification, disassembly and repair

11.1 Conversion and disassembly

NOTICE

Loss of the safety function

Modification of the control block, i.e. fitting solenoid valves other than the factory-installed valves

→ 12 Spare parts and accessories, is not permitted, as this measure can result in loss of conformity.

11.2 Repair

NOTICE

If repairs are required, the solenoid valves should be replaced with identical solenoid valves only → 12 Spare parts and accessories. The control block itself cannot be repaired.

- Please consult your regional Festo contact if you have any technical queries → www.festo.com.

Proceed as follows to replace individual, type-equivalent solenoid valves of the control block:

1. Switch off the following energy sources:
 - Operating voltage
 - Compressed air
2. Disconnect the connection to the proximity switches.
3. Loosen the screw on the plug socket of the solenoid coils with a slotted-head screwdriver and remove the socket.

- Loosen 2 retaining screws from the solenoid valve with a SW3 Allen key and remove the solenoid valve from the control block.
- Take a new solenoid valve of the same type.
- Make sure that the “ISO” marking for unducted pilot exhaust air is visible on the inserted seal → Fig. 12.
If the “ISO” marking is visible: re-insert the seal → Fig. 12, [3].
- Position the solenoid valve on the control block (→ Tab. 7 Mounting the solenoid valves on the control block) and tighten the 2 retaining screws with a SW3 Allen key (permissible tightening torque: $2 \text{ Nm} \pm 10\%$).
- Connect solenoid coils and proximity switches → Tab. 6 Contact assignment of the proximity switch with 3-pin M8 plug in accordance with IEC 61076-2-104.
- Carry out a function test to ensure that control block operates properly → 7 Commissioning.

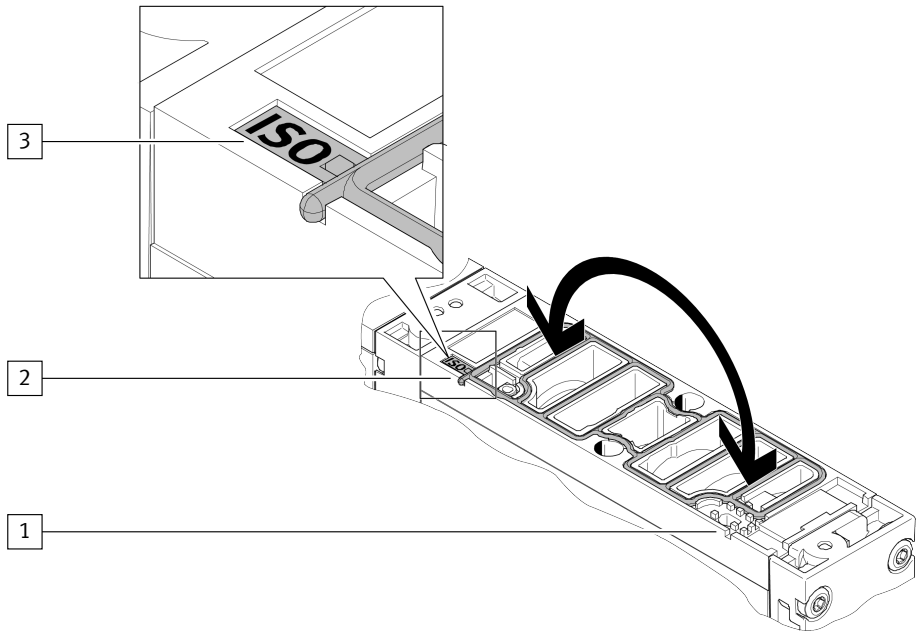
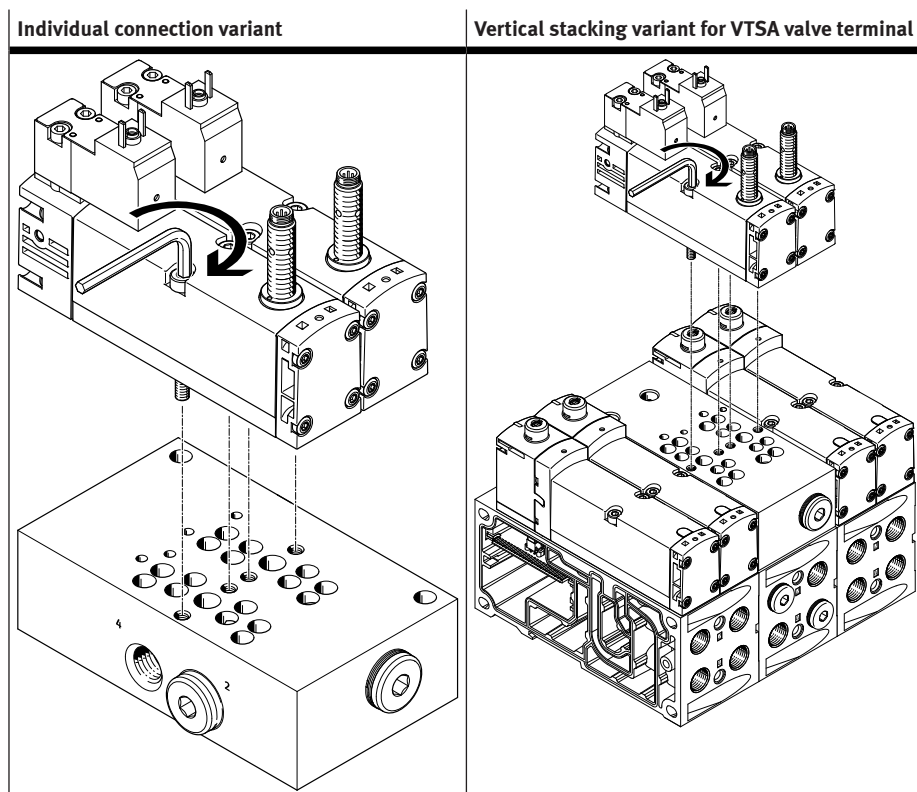

Fig. 12: Position of the valve seal (here: correct position for unducted pilot exhaust air)

- | | |
|--|---|
| <p>[1] Display window on control side 12</p> <p>[2] Seal visible in inspection window on control side 14</p> | <p>[3] Identification label
When in the correct position, the “ISO” marking is visible on the identification label.</p> |
|--|---|



Tab. 7: Mounting the solenoid valves on the control block

11.3 Decommissioning and disposal

As part of our quality assurance process, we are interested in the return of replaced solenoid valves of the control block and would therefore ask you to send them back to Festo.

- Please get in touch with your sales contact to clarify the modalities of the return.
- If you do not return replaced solenoid valves to Festo: dispose of the product in conformity with the local waste disposal regulations. For final disposal of the product, please contact a certified waste management company for electronic waste. The material used in the packaging has been specifically chosen for its recyclability.

12 Spare parts and accessories

NOTICE

Loss of the safety function

Modification of the control block, i.e. fitting solenoid valves other than the factory-installed valves is not permitted, as this measure can result in loss of conformity.

Designation	Type	Part number
Solenoid valve with PNP proximity switch	VSVA-M52-A1-1C1-APP-ET	748020
Solenoid valve with NPN proximity switch	VSVA-M52-A1-1C1-ANP-ET	748021

Tab. 8: Spare part overview

Designation	Type	Part number
Silencer	UO-1/4	197584

Tab. 9: Accessories

13 Technical data

Safety engineering	
Conforms to standard	EN ISO 13849
Characteristics	
Max. achievable category	4
Max. achievable performance level	PL e
Service-life value B_{10}	10 million switching cycles
Diagnostic coverage (DC)	99% if the logic operation of the control signal and the signal change of the proximity switch (expected action) is checked every time both solenoid valves are actuated
Probability of a dangerous failure per hour (PFH _D)	→ Tab. 11 PFH _D value (examples) as a function of the average number of annual actuations n_{op} and → Fig. 13
duration of use T_M	20 a
well-tried component	yes

Safety engineering	
Additional key features	
Fault exclusion ¹⁾	<ul style="list-style-type: none"> - Connection between port (2) and (4) - Punching of the seal - Pressure build-up at port (4) with exhausted port (5) in normal position - Rupture of the valve housing
Design features	<ul style="list-style-type: none"> - overlap - pilot-actuated piston slide
CE marking (→ declaration of conformity → www.festo.com/sp)	<ul style="list-style-type: none"> - in accordance with EU EMC Directive 2014/30/EU - in accordance with EU Machinery Directive 2006/42/EC

1) Faults that do not need to be taken into consideration by the user when analysing possible errors of a safety-related part of a control system

Tab. 10: Safety engineering

The control block is a 2-channel subsystem. The characteristic values for safety engineering (→ Tab. 10 Safety engineering) apply for each channel. The PFH_D value of the subsystem (→ Tab. 11 PFH_D value (examples) as a function of the average number of annual actuations n_{op} and → Fig. 13) can, for example, be calculated with SISTEMA using the following values:

- service-life value B_{10D} = 2 x B₁₀ (in accordance with EN ISO 13849-1, Table C.1, Note 1)
- average annual number of actuations (n_{op})
- diagnostic coverage (DC) per channel of 99%
- CCF with a value of 65 points
- expert setting, limitation of the MTTF_d value to 2500 a

i

SISTEMA is a software wizard for "evaluation of safety-related machine controls in accordance with DIN EN ISO 13849" → <https://www.dguv.de/webcode.jsp?query=d11223>.

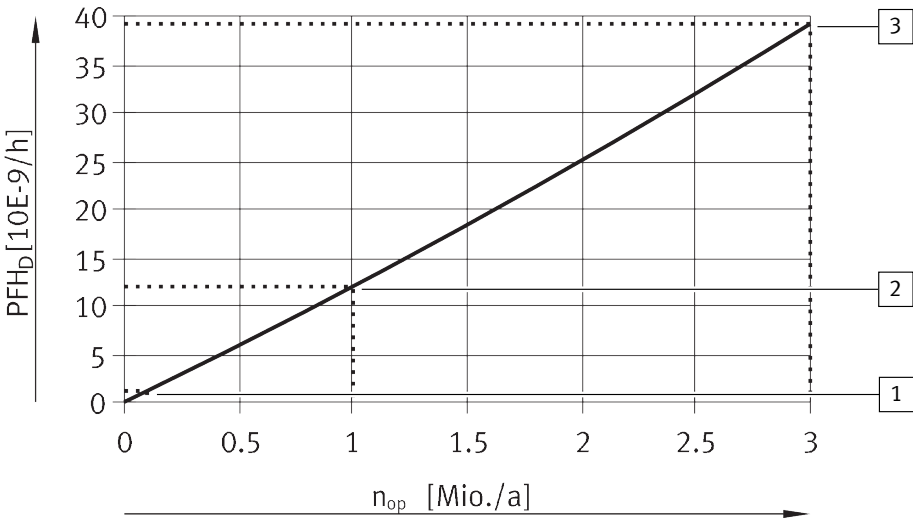

Fig. 13: PFH_D value as a function of the average number of actuations per year n_{op}

Item no. from Fig. 13	average annual number of actuations n _{op} [1/a]	PFH _D value [10 ⁻⁹ /h]
1	100 000	1.1
2	1 000 000	12.0
3	3 000 000	39.2

Tab. 11: PFH_D value (examples) as a function of the average number of annual actuations n_{op}

i

The PFH_D value was calculated with SISTEMA in expert setting with limitation of the MTTF value to 2500 a.

NOTICE

Note the operating time of your control block (T_{10D}, in accordance with EN ISO 13849-1, C.3). The operating time depends on the service-life characteristic (B_{10D}) and the average number of annual actuations (n_{op}), and it may be shorter than the specified duration of use depending on your application (→ Tab. 10 Safety engineering). The solenoid valves of the control block must be replaced at the end of the operating period at the latest.

Technical data

General	Individual connection	Vertical stacking
Permitted temperature ranges		
Storage ¹⁾	-20 °C ... +60 °C	
Environment	-5 °C ... +50 °C	
Medium	-5 °C ... +50 °C	
Tightening torques		
Solenoid coil socket	0.5 Nm ... 0.6 Nm	
Solenoid valve on control block	2 Nm (± 10%)	
Materials – RoHS-compliant		
Sub-base	Wrought aluminium alloy	
Housing	Die-cast aluminium, PA	
Seals	NBR, FPM, HNBR	
Screws	Galvanised steel	
Plug connector-housing, proximity switch	Brass, chrome-plated	
Sensor housing	high-alloy stainless steel	
Cable sheath, proximity switch	PUR	
Foil covering	PC	
Spring	Stainless steel	
Spring fixture	POM	
Vibration and shock, severity level 2 (→ Tab. 13 Values for vibration and shock in accordance with IEC 60068)		
Vibration (“transport application test”)	tested in accordance with IEC 60068-2-6	
Shock (“Shock test”)	tested in accordance with IEC 60068-2-27	
Electromagnetic compatibility (EMC)		
Interference emission	Declaration of conformity → www.festo.com/sp	
Immunity to interference		
Additional key features		
Nominal insert height ²⁾ above sea level	up to 1000 m	
Degree of protection	IP65, Nema 4 (with cable from Festo accessories)	
Relative humidity	max. 90%	

Technical data

General	Individual connection	Vertical stacking
Corrosion protection	corrosion stress not permissible, such as from acidic or saline media	
Mounting position	any, valve preferably positioned with longitudinal axis vertical (90°) to the main direction of vibration	
Dimensions length/width/height	123/69/106 mm	134/53/106 mm without adjoining configuration-dependent valve terminal components
Weight	1138 g	1112 g without adjoining configuration-dependent valve terminal components
Permissible magnetic field strength of a magnetic disruption field	60 mT	

1) Store product in suitable packaging, protected from shock and moisture. The original packaging provides sufficient protection.

2) Design of the solenoid coil in accordance with VDE0580

Tab. 12: General information

Severity level	Vibration	Shock	Continuous shock
2	0.35 mm travel at 10 ... 60 Hz; 5 g acceleration at 60 ... 150 Hz	± 30 g at 11 ms duration; 5 shocks per direction	–

Tab. 13: Values for vibration and shock in accordance with IEC 60068

Pneumatics	Individual connection	Vertical stacking
Valve design		
design	Sub-base valves with piston spool	
Sealing principle	Cartridge, soft sealing	
Lap	overlap	
Exhaust function	can be throttled	
Valve function	5/2-way valves, single-solenoid, neutral position closed	
Reset method	mechanical spring	
Direction of flow	not reversible	
Suitability for vacuum	no	

Pneumatics		Individual connection	Vertical stacking
Control			
Type of control	piloted		
Pilot air supply	internal	through VTSA valve terminal	
Pressure range of the solenoid valves			
Operating pressure	3 bar ... 10 bar	0 bar ... 10 bar	
Operating pressure with internal pilot air supply	–	3 bar ... 10 bar	
Pilot pressure	3 bar ... 10 bar		
Additional key features			
Medium ¹⁾	Compressed air in accordance with ISO 8573-1:2010 [7:4:4]		
Residual oil content ²⁾ when using ester oils	< 0.1 mg/m ³ , corresponds to ISO 8573:2010 [-:-:2]		
Manual override	None		
Standard nominal flow rate port (1) → (2)	950 l/min	830 l/min	

1) The pressure dew point must be at least 10 K lower than the temperature of the medium, since ice would otherwise form in the expanded compressed air.

2) lubricated operation possible, required for further operation

Tab. 14: Pneumatics

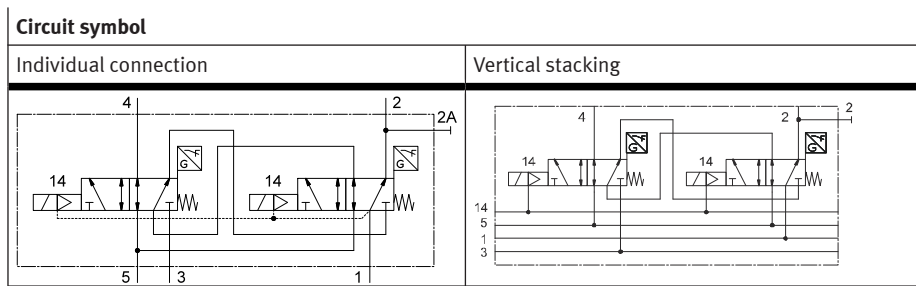

Tab. 15: Circuit symbols of the control block

Switching times ¹⁾ ± 20%		Individual connection			Vertical stacking		
		3	6	10	3	6	10
Operating pressure	[bar]	3	6	10	3	6	10
Valve switching times ON	[ms]	37	22	15	37	22	16
Valve switching times OFF	[ms]	35	56	71	35	59	68

Switching times ¹⁾ ± 20%	[bar]	Individual connection			Vertical stacking		
		3	6	10	3	6	10
Signal drop PNP ²⁾ (Period from energising the solenoid coil until the proximity switch is switched off)	[ms]	21	11	9	21	11	9
Signal rise PNP ²⁾ (Period from the solenoid coil being de-energized until the proximity switch is switched on)	[ms]	37	60	74	37	60	71

1) Applies for new products. Switching times can increase over the service life of the product due to changes in friction coefficients.

2) Signal drop and rise are interchanged when using NPN proximity switches.

Tab. 16: Switching times as a function of operating pressure

Electrical	
Operating voltage supply of solenoid valves	
Nominal voltage	24 V DC
Permissible voltage fluctuations	-15 % ... +10%
Duty cycle	100%
Duration of the test pulses for the control system	
Max. positive test pulse with logic 0	1000 µs
Max. negative test pulse with logic 1	800 µs
Additional key features	
Drop-off current ¹⁾	≥ 2 mA
Output per solenoid coil	1.8 W (at 24 V DC)
Minimum switching frequency of the solenoid valves	Switch at least once per week
Electrical connection	EN 175301-803, type C, without PE conductor

1) Drop-off current is the current below which the armature returns from its stroke end position back to the stroke starting position.

Tab. 17: Electrical

Proximity switch	
Operating voltage supply	
Nominal voltage	24 V DC
Operating voltage range	10 V DC ... 30 V DC
Residual ripple	± 10 %

Proximity switch	
Additional key features	
Conforms to standard	EN 60947-5-2
Switching element function	N/C
Measurement principle	inductive
Switching status indication	yellow LED
Max. switching frequency	5000 Hz
Switching output	PNP or NPN
Max. output current	200 mA
No-load supply current	≤ 10 mA
Voltage drop	≤ 2 V
Short circuit current rating	yes, pulsed
Reverse-polarity protection	yes, for all contacts
Electrical connection	M8x1 plug, 3-pin in accordance with EN 61067-2-104

Tab. 18: Proximity switch

Proximity switch		
Sensor characteristics	...-APP	...-ANP
Switching output type	PNP	NPN
Circuit symbol		

Tab. 19: Circuit symbol of the proximity switch

Copyright:
Festo SE & Co. KG
73734 Esslingen
Ruiter Straße 82
Deutschland

Phone:
+49 711 347-0

Internet:
www.festo.com