

Housing - HC-STA-B32-CHWD-1TTP29-ELC-AL - 1424839

Please be informed that the data shown in this PDF Document is generated from our Online Catalog. Please find the complete data in the user's documentation. Our General Terms of Use for Downloads are valid (<http://phoenixcontact.com/download>)



Coupling housings B32, with double locking latch, material: Die-cast aluminum, salt water resistant, cable outlets: 1, straight, height: 99.8 mm, cable gland: none, support sleeve: no, 1x Pg29, Standard

Your advantages

- good shielding in the event of electromagnetic interference



Key Commercial Data

Packing unit	1 pc
GTIN	
GTIN	4055626382449
Weight per Piece (excluding packing)	436.000 g
Custom tariff number	85389099
Country of origin	China

Technical data

Dimensions

Height	99.8 mm
Width	82.5 mm
Length	94 mm

Ambient conditions

Degree of protection (IP)	IP66
	IP67
Ambient temperature (operation)	-40 °C ... 125 °C

General

Size	B32
Housing type	Coupling housings
Color	gray aluminum

Housing - HC-STA-B32-CHWD-1TTP29-ELC-AL - 1424839

Technical data

General

Locking type	with double locking latch
No. of cable outlets	1
Cable outlet	straight
Screw connection	none
Type of the screw connection	1x Pg29
Housing material	Die-cast aluminum, salt water resistant
Housing surface material	uncoated
Seal material	NBR, conductive
Material lock	PA
Flammability rating according to UL 94	V0 (Interlock)

Environmental Product Compliance

China RoHS	Environmentally Friendly Use Period = 50 years
	For details about hazardous substances go to tab "Downloads", Category "Manufacturer's declaration"

Drawings

Dimensional drawing

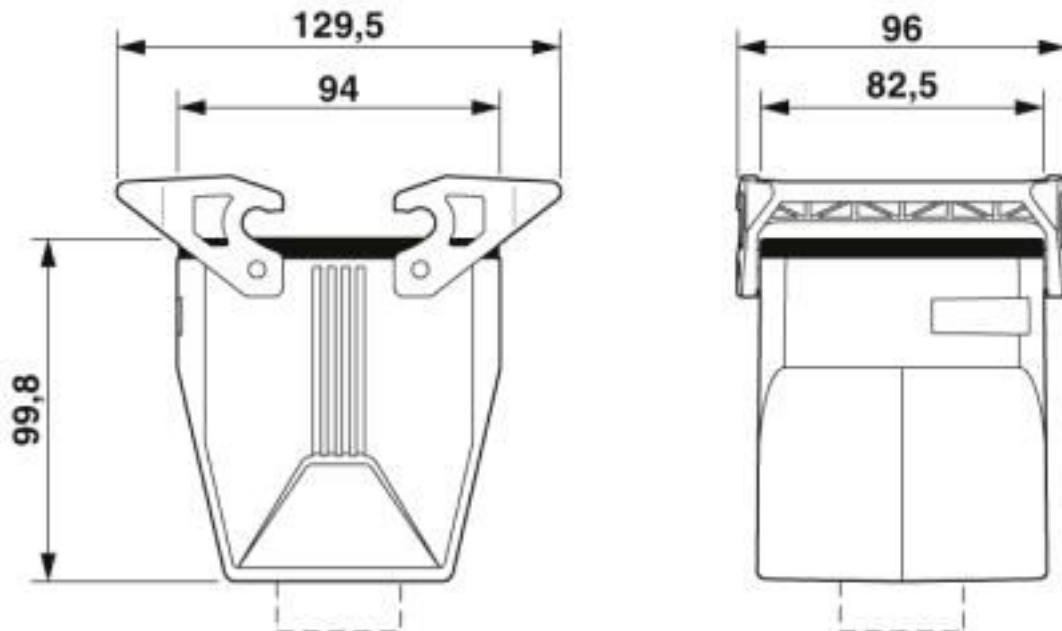

Dimensional drawing

Classifications

eCl@ss

eCl@ss 10.0.1	27440202
---------------	----------

Housing - HC-STA-B32-CHWD-1TTP29-ELC-AL - 1424839

Classifications

eCl@ss

eCl@ss 5.1	27261200
eCl@ss 6.0	27261200
eCl@ss 7.0	27440202
eCl@ss 8.0	27440202
eCl@ss 9.0	27440202

ETIM

ETIM 5.0	EC000437
ETIM 6.0	EC000437
ETIM 7.0	EC000437

Approvals

Approvals

Approvals

DNV GL

Ex Approvals

Approval details

DNV GL		https://approvalfinder.dnvgl.com/	TAE000037S
--------	---	---	------------

Accessories

Accessories

Protective cover

Protective covers - HC-STA-B32-BCSFD-PL-BK - 1424850



Protective cover B32, for double locking latch, protective cover material: PA, height: 24.8 mm, seal: no, Standard, with lanyard