

DESCRIPTION: 979 SERIES D-SUB BACKSHELL - DIE CAST

ALL TOLERANCES = ± 0.3
UNLESS OTHERWISE INDICATED

DESIGNED TO ACCOMMODATE STANDARD:
D-SUB - Shell Size 4

BACKSHELL KIT INCLUDES:

- 2 - BACKSHELL HALVES
- 2 - 4-40 MATING SCREWS
- 2 - SADDLE WASHERS
- 2 - HOUSING SCREWS
- 2 - HOUSING NUTS
- 1 - GROMMET TREE - VARIOUS SIZES
(NON-CONDUCTIVE GROMMETS)

MATERIAL: DIE-CAST ZINC ALLOY
PLATING: NICKEL
OPERATING TEMPERATURE: -45°C TO + 120°C

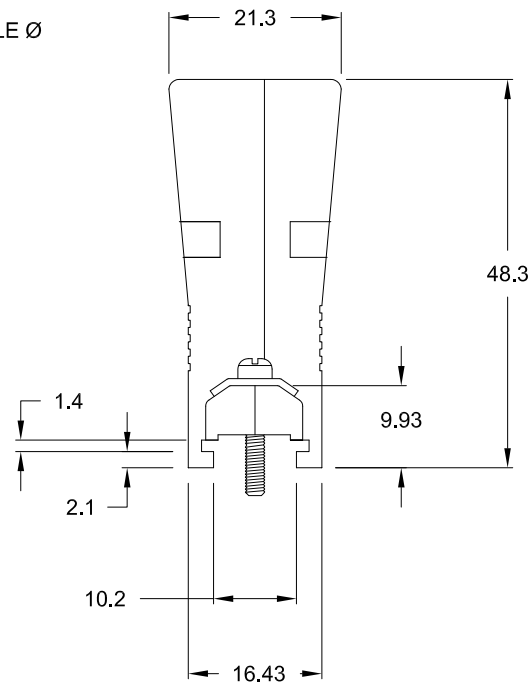
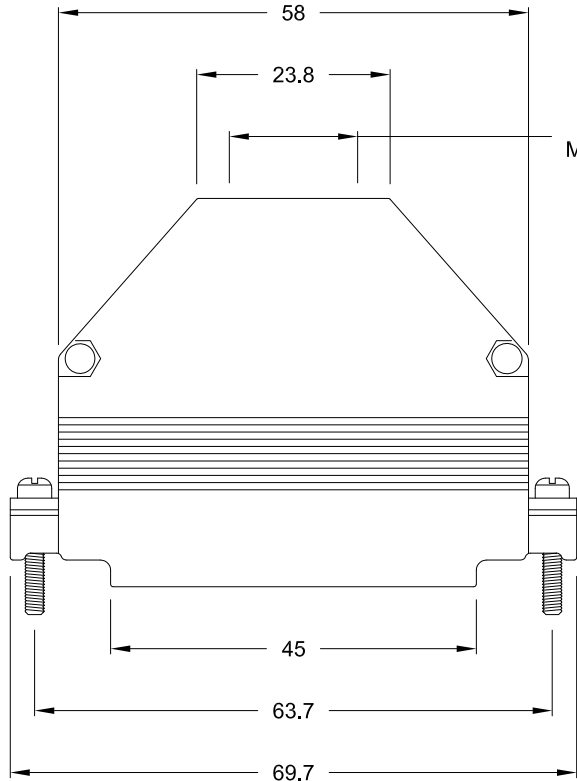

979-037-030 R 12 1

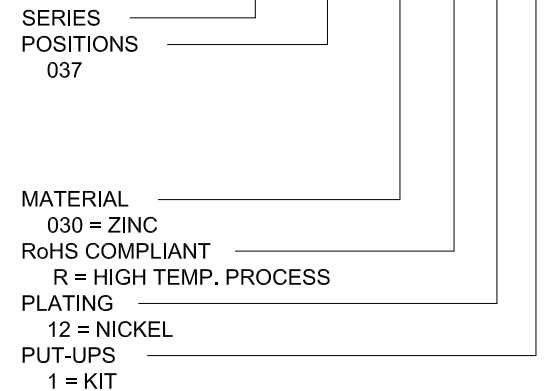

UNITS = mm

DO NOT SCALE FROM DRAWING

RoHS COMPLIANT

	THESE DRAWINGS AND SPECIFICATIONS ARE THE PROPERTY OF NorComp AND SHALL NOT BE REPRODUCED, COPIED OR USED AS THE BASIS FOR THE MANUFACTURE OF SALE OF APPARATUS WITHOUT WRITTEN PERMISSION.		DRAWN: C. SMITH	DATE: 04-20-10
	<h1>NorComp</h1>		SCALE: NTS	SHEET 1 OF 2
DWG NO. 979-037-030R121				

DESCRIPTION: 979 SERIES D-SUB BACKSHELL - HARDWARE

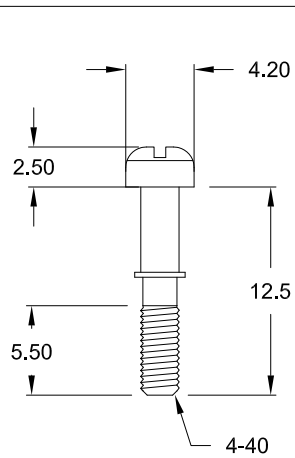

MATING SCREW

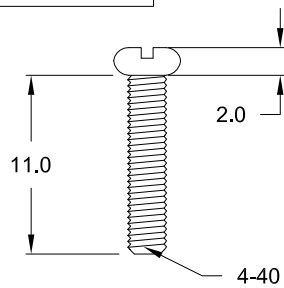

HOUSING SCREW

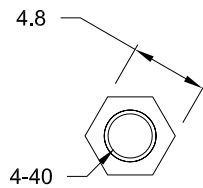

HOUSING NUT

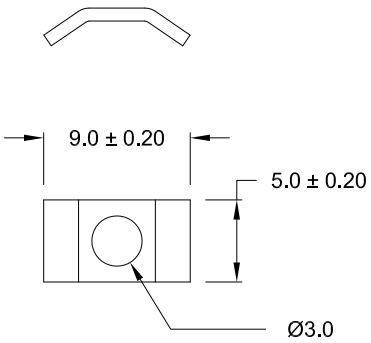

SADDLE WASHER

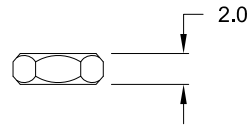

ALL HARDWARE:

MATERIAL = STEEL
PLATING = NICKEL

RoHS COMPLIANT

MAX. CABLE DIAMETER

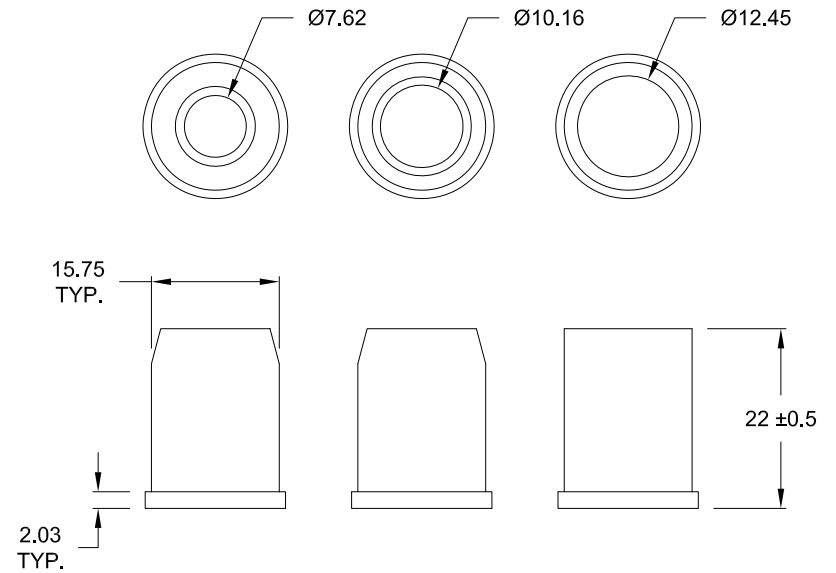

MATERIAL: NON CONDUCTIVE PVC - BLACK
P/N: 162-000-037R000

UNITS = mm

DO NOT SCALE FROM DRAWING



THESE DRAWINGS AND SPECIFICATIONS ARE THE PROPERTY OF NorComp AND SHALL NOT BE REPRODUCED, COPIED OR USED AS THE BASIS FOR THE MANUFACTURE OF SALE OF APPARATUS WITHOUT WRITTEN PERMISSION.

DRAWN: C. SMITH

DATE: 04-20-10

NorComp

SCALE: NTS SHEET 2 OF 2 REV 5

DWG NO. 979-037-030R121