



### Main

Range of product	Altivar Process ATV900
Product or component type	Variable speed drive
Device application	Industrial application
Device short name	ATV930
Variant	Standard version With braking chopper
Product destination	Asynchronous motors Synchronous motors
Mounting mode	Wall mount
EMC filter	Integrated conforming to EN/IEC 61800-3 category C2 with 50 m motor cable maxi Integrated conforming to EN/IEC 61800-3 category C3 with 150 m motor cable maxi
IP degree of protection	IP21 conforming to IEC 61800-5-1 IP21 conforming to IEC 60529
Degree of protection	UL type 1 conforming to UL 508C
Type of cooling	Forced convection
Supply frequency	50...60 Hz (+/- 5 %)
Network number of phases	3 phases
[Us] rated supply voltage	380...480 V (- 15...10 %)
Motor power kW	30 kW (normal duty) 22 kW (heavy duty)
Motor power hp	40 hp (normal duty) 30 hp (heavy duty)
Line current	53.3 A at 380 V (normal duty) 45.9 A at 480 V (normal duty) 40.5 A at 380 V (heavy duty) 35.8 A at 480 V (heavy duty)
Prospective line Isc	50 kA
Apparent power	29.8 kVA at 480 V (heavy duty) 38.1 kVA at 480 V (normal duty)
Continuous output current	61.5 A at 4 kHz (normal duty) 46.3 A at 4 kHz (heavy duty)

Disclaimer: This documentation is not intended as a substitute for and is not to be used for determining suitability or reliability of these products for specific user applications

Maximum transient current	69.5 A during 60 s (heavy duty) 73.8 A during 60 s (normal duty)
Asynchronous motor control profile	Optimized torque mode Variable torque standard Constant torque standard
Synchronous motor control profile	Permanent magnet motor
Speed drive output frequency	0.1...599 Hz
Nominal switching frequency	4 kHz
Switching frequency	2...16 kHz adjustable 4...16 kHz with derating factor
Safety function	STO (safe torque off) SIL 3
Discrete input logic	16 preset speeds
Communication port protocol	Ethernet/IP Modbus TCP Modbus serial
Option card	Slot A : communication module for Profibus DP V1 Slot A : communication module for Profinet Slot A : communication module for DeviceNet Slot A : communication module for CANopen daisy chain RJ45 Slot A : communication module for CANopen SUB-D 9 Slot A : communication module for CANopen screw terminals Slot A : communication module for EtherCAT Slot A/slot B/slot C : digital and analog I/O extension module Slot A/slot B/slot C : output relay extension module Slot B : 5/12 V digital encoder interface module Slot B : analog encoder interface module Slot B : resolver encoder interface module

## Complementary

Output voltage	<= power supply voltage
Motor slip compensation	Automatic whatever the load Adjustable Can be suppressed Not available in permanent magnet motor law
Acceleration and deceleration ramps	Linear adjustable separately from 0.01...9999 s
Braking to standstill	By DC injection
Protection type	Motor : thermal protection Motor : safe torque off Motor : motor phase break Drive : thermal protection Drive : safe torque off Drive : overheating Drive : overcurrent between output phases and earth Drive : overload of output voltage Drive : short-circuit protection Drive : motor phase break Drive : overvoltages on the DC bus Drive : line supply overvoltage Drive : line supply undervoltage Drive : line supply phase loss Drive : overspeed Drive : break on the control circuit
Frequency resolution	Display unit : 0.1 Hz Analog input : 0.012/50 Hz
Electrical connection	Line side, screw terminal : 25...50 mm <sup>2</sup> (AWG 4...AWG 1) Motor, screw terminal : 25...50 mm <sup>2</sup> (AWG 4...AWG 1) Control, screw terminal : 0.5...1.5 mm <sup>2</sup> (AWG 20...AWG 16) DC bus, screw terminal : 25...50 mm <sup>2</sup> (AWG 4...AWG 1)
Connector type	2 RJ45 (on the control block) for Ethernet IP/Modbus TCP 1 RJ45 (on the control block) for Modbus serial
Physical interface	2-wire RS 485 for Modbus serial
Transmission frame	RTU for Modbus serial
Transmission rate	10/100 Mbit/s for Ethernet IP/Modbus TCP 4.8, 9.6, 19.2, 38.4 kbit/s for Modbus serial
Exchange mode	Half duplex, full duplex, autonegotiation for Ethernet IP/Modbus TCP

Data format	8 bits, configurable odd, even or no parity for Modbus serial
Type of polarization	No impedance for Modbus serial
Number of addresses	1...247 for Modbus serial
Method of access	Slave for Modbus TCP
Supply	External supply for digital inputs : 24 V DC (19...30 V) current $\leq$ 1.25 mA (overload and short-circuit protection) Internal supply for reference potentiometer (1 to 10 kOhm) : 10.5 V DC $\pm$ 5 % current $\leq$ 10 mA (overload and short-circuit protection) Internal supply for digital inputs and STO : 24 V DC (21...27 V) current $\leq$ 200 mA (overload and short-circuit protection)
Local signalling	3 mono/dual colour LED for local diagnostic 5 dual colour LED for embedded communication status 2 dual colour LED for communication module status 1 red LED for presence of voltage
Width	226 mm
Height	673 mm
Depth	274 mm
Product weight	28 kg
Analogue input number	3
Analogue input type	Software-configurable voltage AI1, AI2, AI3 : 0...10 V DC impedance 30 kOhm, resolution 12 bits Software-configurable current AI1, AI2, AI3 : 0...20 mA/4...20 mA impedance 250 Ohm, resolution 12 bits
Discrete input number	10
Discrete input type	Programmable DI1...DI8 : 24 V DC ( $\leq$ 30 V) impedance 3.5 kOhm Programmable as pulse input DI7, DI8 0...30 kHz : 24 V DC ( $\leq$ 30 V) Safe torque off STOA, STOB : 24 V DC ( $\leq$ 30 V) impedance $>$ 2.2 kOhm
Input compatibility	Discrete input STOA, STOB : level 1 PLC conforming to EN/IEC 61131-2 Discrete input DI1...DI8 : level 1 PLC conforming to EN/IEC 61131-2 Pulse input DI7, DI8 : level 1 PLC conforming to IEC 65A-68
Discrete input logic	STOA, STOB, positive logic (source) : $<$ 5 V (state 0) $>$ 11 V (state 1) DI1...DI8, positive logic (source) : $<$ 5 V (state 0) $>$ 11 V (state 1) DI1...DI8, negative logic (sink) : $>$ 16 V (state 0) $<$ 10 V (state 1) DI7, DI8, positive logic (source) : $<$ 0.6 V (state 0) $>$ 2.5 V (state 1)
Analogue output number	2
Analogue output type	Software-configurable voltage AQ1, AQ2 : 0...10 V DC impedance 470 Ohm, resolution 10 bits Software-configurable current AQ1, AQ2 : 0...20 mA impedance 500 Ohm, resolution 10 bits
Discrete output number	2
Discrete output type	Logic output DQ+ : 0...1 kHz ( $\leq$ 30 V) DC, $<$ 100 mA Programmable as pulse output DQ+ : 0...30 kHz ( $\leq$ 30 V) DC, $<$ 20 mA Logic output DQ- : 0...1 kHz ( $\leq$ 30 V) DC, $<$ 100 mA
Sampling duration	Discrete input DI1...DI8 : 2 ms ( $\pm$ 0.5 ms) Pulse input DI7, DI8 : 5 ms ( $\pm$ 1 ms) Analog input AI1, AI2, AI3 : 1 ms ( $\pm$ 1 ms) Analog output AQ1, AQ2 : 5 ms ( $\pm$ 1 ms)
Accuracy	Analog input AI1, AI2, AI3 : $\pm$ 0.6 % for a temperature variation 60 °C Analog output AQ1, AQ2 : $\pm$ 1 % for a temperature variation 60 °C
Linearity error	Analog input AI1, AI2, AI3 : $\pm$ 0.15 % of maximum value Analog output AQ1, AQ2 : $\pm$ 0.2 %
Relay output number	3
Relay output type	Configurable relay logic R1 : fault relay NO/NC electrical durability 100000 cycles Configurable relay logic R2 : sequence relay NO electrical durability 1000000 cycles Configurable relay logic R3 : sequence relay NO electrical durability 1000000 cycles
Refresh time	Relay output R1, R2, R3 : 5 ms ( $\pm$ 0.5 ms)
Minimum switching current	Relay output R1, R2, R3 : 5 mA at 24 V DC
Maximum switching current	Relay output R1 on inductive load (cos phi = 0.4 and L/R = 7 ms) : 2 A at 250 V AC Relay output R1 on inductive load (cos phi = 0.4 and L/R = 7 ms) : 2 A at 30 V DC Relay output R2, R3 on inductive load (cos phi = 0.4 and L/R = 7 ms) : 2 A at 250 V AC Relay output R2, R3 on inductive load (cos phi = 0.4 and L/R = 7 ms) : 2 A at 30 V DC Relay output R1 on resistive load (cos phi = 1) : 3 A at 250 V AC Relay output R1 on resistive load (cos phi = 1) : 3 A at 30 V DC Relay output R2, R3 on resistive load (cos phi = 1) : 5 A at 250 V AC Relay output R2, R3 on resistive load (cos phi = 1) : 5 A at 30 V DC
Isolation	Between power and control terminals

Specific application	Process
IP degree of protection	IP21
Discrete and process manufacturing	Food and beverage processing mixer Food and beverage processing conveyor Food and beverage processing shredder Hoisting process crane Marine thruster Marine winch Material working (wood, ceramic, stone, pvc, metal) press Material working (wood, ceramic, stone, pvc, metal) extruder Mining mineral and metal other application Oil and gas drilling rig Oil and gas progressive cavity pump Oil and gas rod pump Oil and gas swapping pump Oil and gas compressor for regasification Oil and gas separator Oil and gas other application Water and waste water separator
Power range	30...50 kW 380...440 V 3 phases 30...50 kW 480...500 V 3 phases
Motor starter type	Variable speed drive

## Environment

Insulation resistance	> 1 mOhm at 500 V DC for 1 minute to earth
Noise level	71.5 dB conforming to 86/188/EEC
Power dissipation in W	93 W (natural convection) at 380 V switching frequency 4 kHz 640 W (forced convection) at 380 V switching frequency 4 kHz
Volume of cooling air	240 m <sup>3</sup> /h
Operating position	Vertical +/- 10 degree
THDI	<= 48 % from 80...100 % of load conforming to IEC 61000-3-12
Electromagnetic compatibility	1.2/50 µs - 8/20 µs surge immunity test level 3 conforming to IEC 61000-4-5 Electrical fast transient/burst immunity test level 4 conforming to IEC 61000-4-4 Electrostatic discharge immunity test level 3 conforming to IEC 61000-4-2 Radiated radio-frequency electromagnetic field immunity test level 3 conforming to IEC 61000-4-3 Conducted radio-frequency immunity test level 3 conforming to IEC 61000-4-6
Pollution degree	2 EN/IEC 61800-5-1
Vibration resistance	1.5 mm peak to peak (f = 2...13 Hz) conforming to IEC 60068-2-6 1 gn (f = 13...200 Hz) conforming to IEC 60068-2-6
Shock resistance	15 gn during 11 ms conforming to IEC 60068-2-27
Relative humidity	5...95 % without condensation conforming to IEC 60068-2-3
Ambient air temperature for operation	-15...50 °C without derating 50...60 °C with derating factor
Ambient air temperature for storage	-40...70 °C
Operating altitude	1000...4800 m with current derating 1 % per 100 m <= 1000 m without derating
Environmental characteristic	Chemical pollution resistance class 3C3 conforming to EN/IEC 60721-3-3 Dust pollution resistance class 3S3 conforming to EN/IEC 60721-3-3
Standards	EN/IEC 61800-3 UL 508C EN/IEC 61800-5-1 IEC 61000-3-12 IEC 60721-3 IEC 61508 IEC 13849-1 EN/IEC 61800-3 (environment 1 category C2) EN/IEC 61800-3 (environment 2 category C3)
Product certifications	UL REACH TÜV CSA
Marking	CE

## Offer Sustainability

Sustainable offer status	Green Premium product
RoHS (date code: YYWW)	Compliant - since 1526 - Schneider Electric declaration of conformity <a href="#">Schneider Electric declaration of conformity</a>
REACH	Reference not containing SVHC above the threshold <a href="#">Reference not containing SVHC above the threshold</a>
Product environmental profile	Available <a href="#">Product environmental</a>
Product end of life instructions	Available <a href="#">End of life manual</a>

---

Dimensions

---

Front, Left and Rear View

Clearances

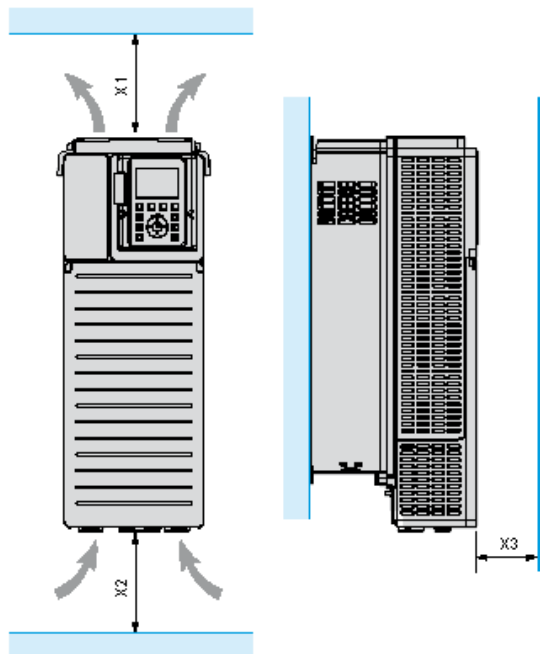

X1	X2	X3
≥ 100 mm (3.94 in.)	≥ 100 mm (3.94 in.)	≥ 10 mm (0.39 in.)

- Mount the device in a vertical position ( $\pm 10^\circ$ ). This is required for cooling the device.
- Do not mount the device close to heat sources.
- Leave sufficient free space so that the air required for cooling purposes can circulate from the bottom to the top of the drive.

---

Mounting Types

---

Mounting Type A: Individual IP21



$a \geq 110 \text{ mm (4.33 in.)}$

Mounting Type B: Side by Side IP20 (Possible, 2 Drives Only)

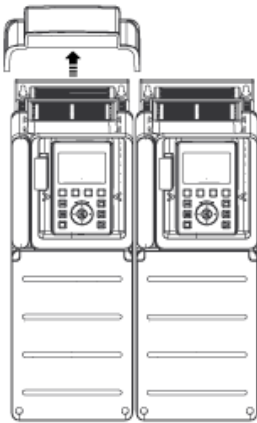

Mounting Type C: Individual IP20

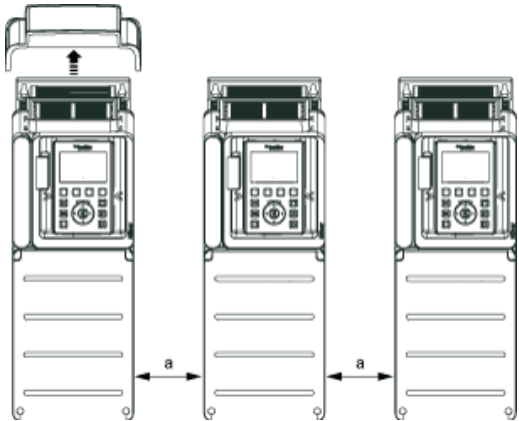

$a \geq 110 \text{ mm (4.33 in.)}$



---

## Three-Phase Power Supply with Upstream Breaking via Line Contactor

---

Connection diagrams conforming to standards EN 954-1 category 1 and IEC/EN 61508 capacity SIL1, stopping category 0 in accordance with standard IEC/EN 60204-1

- (1) Line choke if used
- (2) Use relay R1 set to operating state Fault to switch Off the product once an error is detected.
- A1 : Drive
- KM1 : Line Contactor
- Q2, Q3 : Circuit breakers
- S1, S2 : Pushbuttons
- T1 : Transformer for control part

---

## Three-Phase Power Supply with Downstream Breaking via Contactor

---

Connection diagrams conforming to standards EN 954-1 category 1 and IEC/EN 61508 capacity SIL1, stopping category 0 in accordance with standard IEC/EN 6

- (1) Line choke if used
- (2) Use relay R1 set to operating state Fault to switch Off the product once an error is detected.
- A1 : Drive
- KM1 : Contactor

---

### Control Block Wiring Diagram

---

- (1) Safe Torque Off
  - (2) Analog Output
  - (3) Digital Input
  - (4) Reference potentiometer
  - (5) Analog Input
  - (6) Digital Output
  - (7) 0-10 Vdc, x-20 mA
  - (8) 0-10 Vdc, -10 Vdc...+10 Vdc
- R1A, R1B FULC relay  
R2A, R2C Sequence relay  
R3A, R3C Sequence relay

### Sensor Connection

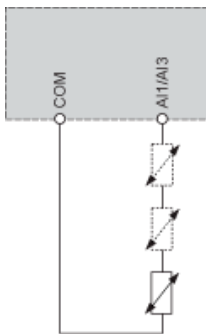

It is possible to connect either 1 or 3 sensors on terminals AI1 or AI3

---

## Sink / Source Switch Configuration

---

The switch is used to adapt the operation of the logic inputs to the technology of the programmable controller outputs.

- Set the switch to Source (factory setting) if using PLC outputs with PNP transistors.
- Set the switch to Ext if using PLC outputs with NPN transistors.

### Switch Set to SRC (Source) Position Using the Output Power Supply for the Digital Inputs

### Switch Set to SRC (Source) Position and Use of an External Power Supply for the DIs

### Switch Set to SK (Sink) Position Using the Output Power Supply for the Digital Inputs

### Switch Set to EXT Position Using an External Power Supply for the DIs

Derating Curves

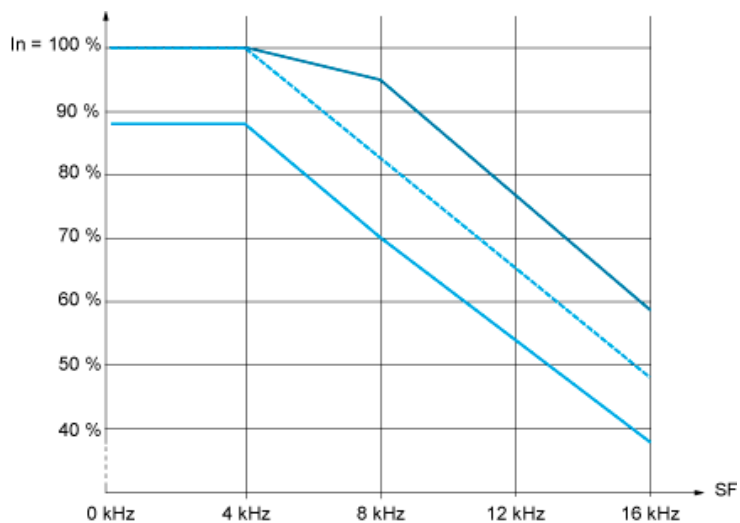

40 °C (104 °F) - Mounting type A, B and C  
50 °C (122 °F) - Mounting type A, B and C  
60 °C (140 °F) - Mounting type B and C

In : Nominal Drive Current  
SF : Switching Frequency

Our Proposal: Circuit Breaker + Contactor + Drive for Motor Power 30 kW and 380 or 440 VAC

Motor power (kW)	ICU (kA)	Breaker	Contactor (*)	Motor Starter
30	50	 GV3L65	LC1D50AP7	ATV930D30N4

Non contractual pictures.

(\*) You can select the contactor proposed or variants. Please consider examples hereafter or follow the link to the complete offer.

Motor power kW	Coil voltage VAC - 50/60 Hz	24	48	110	115	220	230	400	Other
30	LC1D50A ..	B7	E7	F7	FE7	M7	P7	V7	Complete Offer

Motor power kW	Coil voltage VDC	24	48	110	125	220	230	Other
30	LC1D50A ..	BD	ED	-	-	-	-	Complete Offer