



Brand of NTN corporation

## Technical data

### 6003

Single row deep groove ball bearings



Deep groove ball bearing, radial contact, pressed steel cage, open

### VISUAL (S)

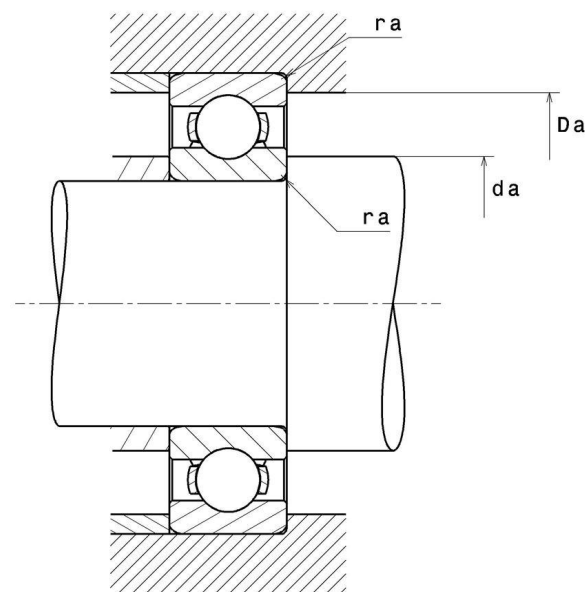
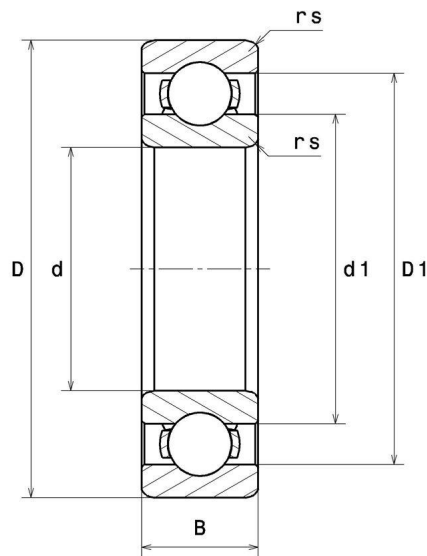

**NTN Europe**

1 rue des Usines · BP 2017 · 74010 Annecy Cedex · France · Tel. +33 (0)4 50 65 30 00  
S.A. au capital de 322 639 919 € · RCS ANNECY B 325 821 072 · Id. Fiscale : FR 48 325 821 072  
SIRET 325 821 072 00015 · Code APE 2815 Z · Code NACE 28.15

## PRODUCT DEFINITION

<b>Brand</b>	SNR
<b>d - Internal diameter</b>	17 mm
<b>D - External diameter</b>	35 mm
<b>B - Bearing/Inner ring width</b>	10 mm
<b>d1 - External diameter inner ring</b>	21,3 mm
<b>D1 - Inner diameter outer ring</b>	31,3 mm
<b>rs - Min fillet radius</b>	0,3 mm
<b>Radial clearance class</b>	CN
<b>Mass</b>	0,035 kg

## PRODUCT PERFORMANCE

<b>C - Dynamic load</b>	6300000 mN
<b>C0 - Static load</b>	3250000 mN
<b>Cu - Fatigue limit load</b>	150000 mN
<b>f0 - Coefficient</b>	14.4
<b>N ref - Reference thermal speed</b>	120000 °/s
<b>N lim - Mechanical Limit Speed</b>	210000 °/s
<b>Tmin - Min operating temperature</b>	233,15 °K
<b>Tmax - Max operating temperature</b>	393,15 °K

## BEARING FREQUENCIES

<b>BPFO - Over rolling frequency on outer ring (60 rpm)</b>	4.084 Hz
<b>BPFI - Over rolling frequency on inner (60 rpm)</b>	5.916 Hz
<b>BSF - Over rolling frequency on rolling element (60 rpm)</b>	5.276 Hz
<b>BRF - Rotational frequency - rolling element (60 rpm)</b>	2.638 Hz



## BEARING FREQUENCIES

FTF - Rotational frequency - cage (60 rpm)

0.408 Hz

## ABUTMENT

da min - Min shoulder diameter IR

19 mm

da max - Max shoulder diameter IR

0 mm

Da max - Max shoulder diameter OR

33 mm

ra max - Max shaft &amp; housing fillet radius

0,3 mm

## OE EQUIVALENTS

Manufacturer

Part number

Mercedes

008 981 3425 | 008 981 5425 | 010 981 8425 | 010 981 9025 |  
A0109818425 | A0109819025

## INDUSTRY CALCUL FACTORS

Equivalent dynamic radial load

$$P = X \cdot Fr + Y \cdot Fa$$

$\frac{f_0 F_a}{C_0}$	e	Fa / Fr ≤ e		Fa / Fr > e	
		X	Y	X	Y
0.172	0.19	1	0	0.56	2.3
0.345	0.22				1.99
0.689	0.26				1.71
1.03	0.28				1.55
1.38	0.3				1.45
2.07	0.34				1.31
3.45	0.38				1.15
5.17	0.42				1.04
6.89	0.44				1

Equivalent static radial load

$$P_0 = X_0 \cdot Fr + Y_0 \cdot Fa$$

$X_0$	$Y_0$
0.6	0.5

For single or DT bearing arrangement:

If  $P_0 < Fr$ , then use  $P_0 = Fr$ 

NTN Europe

1 rue des Usines · BP 2017 · 74010 Annecy Cedex · France · Tel. +33 (0)4 50 65 30 00  
S.A. au capital de 322 639 919 € · RCS ANNECY B 325 821 072 · Id. Fiscale : FR 48 325 821 072  
SIRET 325 821 072 00015 · Code APE 2815 Z · Code NACE 28.15