

# TRUNK LOCK COMPACT

Article Nr. 21.2311/0

[See the product on the website](#) →

[Download CAD Files](#) →

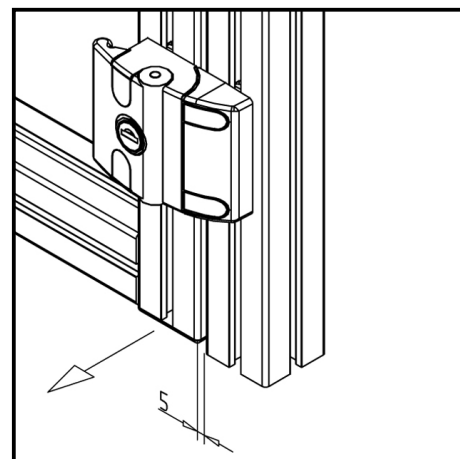
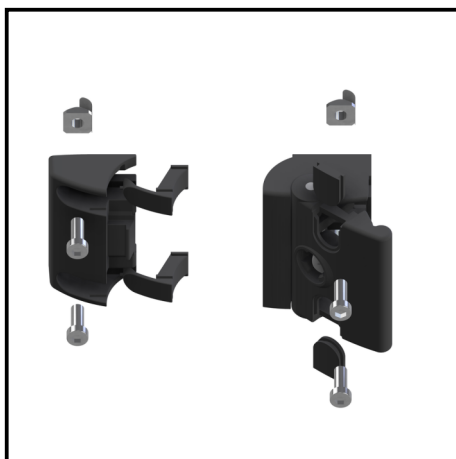
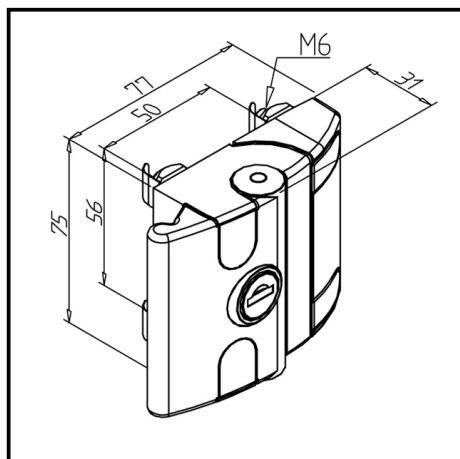

## TECHN. DATA / ITEMS SUPPLIED

- Zinc, Pressure die-casting, powder-coated, black
- With fastening material steel, zinc plated
- Locking cylinder with two keys
- Weight = 0.255 kg/piece

## APPLICATIONS

- Locking and securing of doors and panels in protective housings
- Door stop at the same time
- Also suitable for frameless doors
- Closed trunk can not be removed

## ASSEMBLY

- Mount the latch lock to the door and posts and fit the screw cover
- No machining of the profile is necessary for assembly
- Due to elongated holes, the screw spacing is variably adjustable from min. 38 mm to max. 58 mm, therefore the door gap can be adjusted accordingly