

PTC Thermistors, Overload Protection for Telecommunication

RoHS
COMPLIANT

FEATURES

- Wide resistance range in telecom area from 4 Ω to 70 Ω
- Fast protection against power contact faults
- Withstand high overload currents of up to 10 A
- High voltage withstanding capabilities for the larger sized thermistors (up to 600 V)
- Good tracking over a wide temperature range for all matched or binned thermistors (matching at 85 °C \leq 2 x matching at 25 °C)
- UL1434 approved types available (XGPU2)
- All telecom PTCs are coated with a high temperature silicon lacquer (UL 94 V-0) to protect them from any harsh environments and to improve their lifetime
- Material categorization: for definitions of compliance please see www.vishay.com/doc?99912

APPLICATIONS

Over-temperature/over-load protection:

- Main distribution frame (MDF)
- Central office switching (C.O.)
- Subscriber terminal equipment (T.E.)
- Set-top box (S.B.)

MARKING

Clear marking on a gray coated body
BC and R_{25} value

QUICK REFERENCE DATA		
PARAMETER	VALUE	UNIT
Maximum voltage (RMS or DC)	220 to 600	V_{RMS}
Maximum holding current (I_{nt})	100 to 175	mA
Resistance at 25 °C (R_{25})	8 to 50	Ω
Tolerance on R_{25} value	15 to 25	%
Maximum overload current I_{ol}	0.6 to 10.0	A
Tripping time at 1 A	1 to 40	s
Operating temperature range at max. voltage	0 to 70 (95)	°C

ELECTRICAL DATA AND ORDERING INFORMATION											
RESISTANCE		MATCHING (Ω)	$V_{max.}$ (V_{RMS})	NON-TRIP CURRENT		TRIP CURRENT		MAX. TRIP TIME at 1 A	$I_{max.}$ AT $V_{max.}$	APPLICATION AREA (2)	ORDERING PART NUMBERS
R_{25} (Ω)	TOL. (%)			I_{nt} (mA)	at T (°C)	I_t (mA)	at T (°C)	$t_{max.}$ (S)	$I_{max.}$ (A)		
25	± 20	1.0	220	70	70	200	25	2.5	4.0	C.O.	PTCTL4MR250GTE
10	± 20	1.0	230	100	70	250	25	3.0	2.0	MDF; ISDN	PTCTL3MR100GTE
25	± 15	no	245	70	70	200	25	5.0	2.6	C.O.	PTCTL4NR250GTE
16	± 20	no	245	140	55	270	25	8.0	1.6	T.E.	PTCTL6NR160GTE
10	± 20	no	245	140	55	270	25	8.0	2.0	T.E.	PTCTL6NR100GTE
25	± 20	1.0	250	70	70	175	25	1.3	3.2	MDF; C.O.	PTCTL3MR250HTE
10	± 20	no	250	100	70	450	0	40.0	10.0	T.E.	PTCTL8NR100HBE
8	± 25	0.5	285	135	95	400	25	6.0	0.6	MDF; ISDN	PTCTL4MR080JBE
16	± 25	no	300	100	70	250	25	2.0	2.6	MDF; T.E.	PTCTL3NR160KTE
10	± 20	no	350	100	70	270	25	4.0	1.0	T.E.; S.B.	PTCTL4NR100LBE
10	± 20	1.0	350	100	70	270	25	4.0	1.0	C.O.	PTCTL4MR100LTE
50	± 20	1.0	600	50	70	140	25	1.0	1.0	C.O.	PTCTL4MR500SBE
35	± 20	3.0	600	70	70	600	0	3.0	1.0	C.O.	PTCTL4MR350STE
25	± 20	0.5	600	70	70	170	25	2.5	2.0	C.O.	PTCTL4MR250STE
25	± 20	0.5	600	70	70	170	25	5.0	2.0	C.O.	PTCTL6MR250STE
10	± 20	0.5	600	175	25	400	25	7.0	1.0	C.O.	PTCTL7MR100SBE (1)
10	± 20	no	600	175	25	400	25	7.0	1.0	T.E.; S.B.	PTCTL7NR100SBE (1)

Notes

- All types pass ITU-T K20-21-45 telecommunication protection recommendation
- (1) UL 1434 approved types and compatible with UL1459 and GR1089
- (2) MDF: Main Distribution Frame; C.O.: Central Office Switching; T.E.: Subscriber Terminal Equipment; S.B.: Set-top Box

OVERCURRENT PROTECTION OF TELECOMMUNICATION LINES

The PTC thermistor must protect the telephone line circuit against overcurrent which may be caused by the following events:

- Surges due to lightning strikes on or near to the line plant.
- Short-term induction of alternating voltages from adjacent power lines or railway systems, usually caused when these lines or systems develop faults.
- Direct contact between telephone lines and power lines.

To provide good protection under such conditions a PTC thermistor is connected in series with each line, usually as secondary protection; see Typical Telephone Line drawing fig. 1. However, even with primary line protection (usually a gas discharge tube), the PTC thermistor must fulfil severe requirements.

Surge pulses of up to 2 kV can occur and in order to withstand short-term power induction the PTC thermistor must withstand high voltages. If the line has primary protection a 220 V to 300 V PTC thermistor is adequate. Without primary protection, however, a 600 V PTC device is necessary. Vishay BCcomponents manufactures a range of PTC thermistors (see Electrical Data and Ordering Information Table) covering both requirements.

In the case of direct contact between the telephone line and a power line, the PTC thermistor must withstand very high inrush power at normal mains voltage. Under such conditions, overload currents of up to 10 A on a 230 V mains could occur for up to several hours. To handle this power, the resistance/temperature characteristic of the thermistor must have a very steep slope and the ceramic must be extremely homogeneous.

In case of overcurrent due to short-term induction of alternating voltages, currents of several amperes with voltages as high as 650 V_{RMS} can be present for several seconds.

For standard high voltage applications, resistance values from 25 Ω to 50 Ω are available. However, ISDN networks which carry high-frequency sound and vision, need lower line impedance.

Telecommunication designers are therefore demanding high voltage thermistors with much lower R₂₅ values, which places even greater demands on the manufacture of PTC thermistors. For these applications PTC thermistors which have a R₂₅ value of 10 Ω with voltages in the 300 V_{RMS} to 600 V_{RMS} range are available.

In a typical telephone line application, two PTC thermistors are used, one each for the tip and ring (or A and B) wire together with their series resistors. For good line balance it is important that the thermistor and resistor pairs are matched.

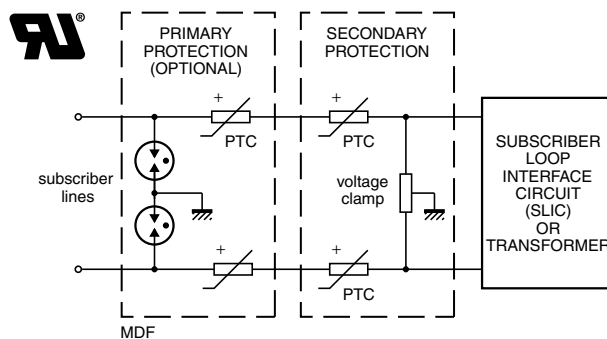
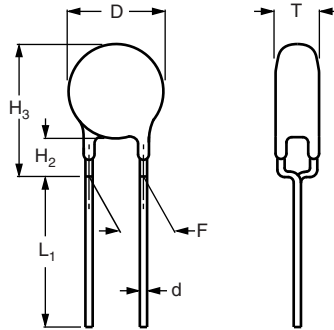

Fig. 1 - Typical telephone line showing where PTC thermistors can be used for overcurrent protection.

PTC THERMISTORS IN BULK

COMPONENT DIMENSIONS (in mm)								
D MAX.	T MAX.	H ₂	L ₁	H ₃ MAX.	H ₀	PACKAGING ⁽¹⁾⁽²⁾		ORDERING PART NUMBER
						TYPE	SPQ	
8.5	5.0	1.5 to 3.0	-	11.5	16	Taped on reel	1500	PTCTL4MR250GTE
7.0	4.0	2.0 ± 0.5	-	9.8	18	Taped on reel	1500	PTCTL3MR100GTE
8.3	4.0	1.5 to 3.0	-	11.0	18	Taped on reel	1500	PTCTL4NR250GTE ⁽³⁾
11	4.5	4.0 ± 1.0	-	15.5	16	Taped on reel	1500	PTCTL6NR160GTE
11	4.5	4.0 ± 1.0	-	15.5	16	Taped on reel	1500	PTCTL6NR100GTE ⁽³⁾
7.0	4.0	2.0 ± 0.5	-	9.8	18	Taped on reel	1500	PTCTL3MR250HTE
13.6	6.0	4.0 ± 1.0	20 ± 4.0	18.6	-	Bulk	200	PTCTL8NR100HBE ⁽³⁾
8.3	5.0	1.5 ± 0.5	20 ± 3.0	10.3	-	Bulk	250	PTCTL4MR080JBE
7.0	4.0	2.5 ± 0.5	-	10.0	16	Taped on reel	1500	PTCTL3NR160KTE
8.5	4.0	2.5 ± 0.5	4.1 ± 0.5	11.5	-	Bulk	500	PTCTL4NR100LBE
8.5	4.0	2.5 ± 0.5	-	11.5	16	Taped on reel	1500	PTCTL4MR100LTE
8.5	4.0	2.5 ± 0.5	4.1 ± 0.5	11.5	-	Bulk	500	PTCTL4MR500SBE
8.0	5.0	2.5 ± 0.5	-	11.0	16	Taped on reel	1500	PTCTL4MR350STE
8.5	4.0	2.0 ± 0.5	-	11.0	16	Taped on reel	1500	PTCTL4MR250STE
10.5	5.0	2.0 ± 0.5	-	12.6	16	Taped on reel	1500	PTCTL6MR250STE
13	5.5	4.0 ± 1.0	20 min.	18.0	-	Bulk	200	PTCTL7MR100SBE
13	5.5	4.0 ± 1.0	20 min.	18.0	-	Bulk	200	PTCTL7NR100SBE

Notes

- (1) Taped in accordance with IEC 60286-2
- (2) Metallized ceramic pellet for clamping or substrate mounting, available on request
- (3) Insulated version is also available

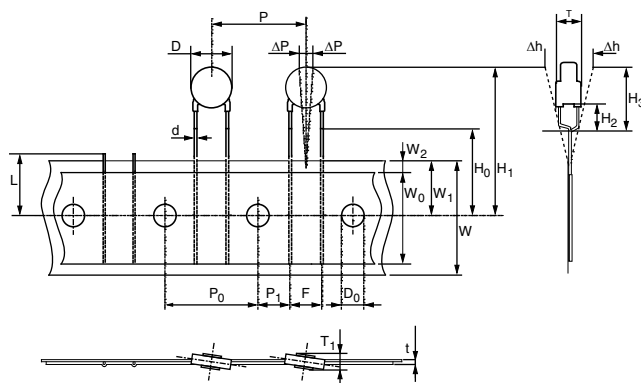
PTC THERMISTORS ON TAPE AND REEL

TAPE AND REEL ACCORDING TO IEC 60286-2 (in mm)			
SYMBOL	PARAMETER	DIMENSIONS	TOLERANCE
D	Body diameter	see table	max.
d	Lead diameter	0.6	± 0.05
P	Pitch between thermistors	12.7	± 1
P ₀	Feedhole pitch	12.7	± 0.3
F	Leadcenter to leadcenter distance (between component and tape)	5	+ 0.5 / - 0.2
H ₀	Lead wire clinch height	see table	± 0.5
H ₂	Component bottom to seating plane	see table	see table
H ₃	Component top to seating plane	see table	max.
T	Total thickness	see table	max.



Disclaimer

ALL PRODUCT, PRODUCT SPECIFICATIONS AND DATA ARE SUBJECT TO CHANGE WITHOUT NOTICE TO IMPROVE RELIABILITY, FUNCTION OR DESIGN OR OTHERWISE.

Vishay Intertechnology, Inc., its affiliates, agents, and employees, and all persons acting on its or their behalf (collectively, "Vishay"), disclaim any and all liability for any errors, inaccuracies or incompleteness contained in any datasheet or in any other disclosure relating to any product.

Vishay makes no warranty, representation or guarantee regarding the suitability of the products for any particular purpose or the continuing production of any product. To the maximum extent permitted by applicable law, Vishay disclaims (i) any and all liability arising out of the application or use of any product, (ii) any and all liability, including without limitation special, consequential or incidental damages, and (iii) any and all implied warranties, including warranties of fitness for particular purpose, non-infringement and merchantability.

Statements regarding the suitability of products for certain types of applications are based on Vishay's knowledge of typical requirements that are often placed on Vishay products in generic applications. Such statements are not binding statements about the suitability of products for a particular application. It is the customer's responsibility to validate that a particular product with the properties described in the product specification is suitable for use in a particular application. Parameters provided in datasheets and / or specifications may vary in different applications and performance may vary over time. All operating parameters, including typical parameters, must be validated for each customer application by the customer's technical experts. Product specifications do not expand or otherwise modify Vishay's terms and conditions of purchase, including but not limited to the warranty expressed therein.

Hyperlinks included in this datasheet may direct users to third-party websites. These links are provided as a convenience and for informational purposes only. Inclusion of these hyperlinks does not constitute an endorsement or an approval by Vishay of any of the products, services or opinions of the corporation, organization or individual associated with the third-party website. Vishay disclaims any and all liability and bears no responsibility for the accuracy, legality or content of the third-party website or for that of subsequent links.

Vishay products are not designed for use in life-saving or life-sustaining applications or any application in which the failure of the Vishay product could result in personal injury or death unless specifically qualified in writing by Vishay. Customers using or selling Vishay products not expressly indicated for use in such applications do so at their own risk. Please contact authorized Vishay personnel to obtain written terms and conditions regarding products designed for such applications.

No license, express or implied, by estoppel or otherwise, to any intellectual property rights is granted by this document or by any conduct of Vishay. Product names and markings noted herein may be trademarks of their respective owners.