

# 8BVI0660HWSA.008-1

---

## 1 General information

- Clearly structured, straightforward implementation via network-based safety technology
- Modular expandability through virtual wiring
- Immediate triggering of safety function due to short cycle times
- Easy implementation with transparent control and status information, even in the standard application
- Compact design

## 2 Order data

Order number	Short description	Figure
	<b>Wall mounting</b>	
8BVI0660HWSA.008-1	ACOPOSmulti SafeMOTION SinCos inverter module, 66 A, AS, wall mounting	
	<b>Required accessories</b>	
	<b>Terminal block sets</b>	
8BZV11650SS.000-1A	Screw clamp terminal block set for ACOPOS-multi 8BVI0660HxSS, 8BVI0880HxSS, 8BVI1650HxSS, 8BVI0660HxSA, 8BVI0880HxSA and 8BVI1650HxSA modules: 1x 8TB2104.203L-00, 1x 8TB2108.2010-00	
	<b>Optional accessories</b>	
	<b>Accessory sets</b>	
8BXB000.0000-00	ACOPOSmulti accessory set for encoder buffering consists of the following: 1 lithium battery AA 3.6 V, 1 cover for battery compartment	
	<b>Fan modules</b>	
8BXF001.0000-00	ACOPOSmulti fan module, replacement fan for ACOPOSmulti modules (8BxP/8B0C/8BVI/8BVE/8B0K)	
	<b>Plug-in modules</b>	
8BAC0120.000-1	ACOPOSmulti plug-in module, EnDat 2.1 interface	
8BAC0120.001-2	ACOPOSmulti plug-in module, EnDat 2.2 interface	
8BAC0121.000-1	ACOPOSmulti plug-in module, HIPERFACE interface	
8BAC0122.000-1	ACOPOSmulti plug-in module, resolver interface 10 kHz	
8BAC0123.000-1	ACOPOSmulti plug-in module, incremental encoder and SSI absolute encoder interface for RS422 signals	
8BAC0123.001-1	ACOPOSmulti plug-in module, incremental encoder interface for 5 V single-ended and 5 V differential signals	
8BAC0123.002-1	ACOPOSmulti plug-in module, incremental encoder interface for 24 V single-ended and 24 V differential signals	
8BAC0124.000-1	ACOPOSmulti plug-in module, SinCos interface	
8BAC0125.000-1	ACOPOSmulti plug-in module, SinCos EnDat 2.1/SSI/BISS interface	
8BAC0130.000-1	ACOPOSmulti plug-in module, 2 digital outputs, 50 mA, max. 62.5 kHz, 2 digital outputs, 500 mA, max. 1.25 kHz, 2 digital inputs 24 VDC	
8BAC0130.001-1	ACOPOSmulti plug-in module, 2 digital outputs, 50 mA, max. 62.5 kHz, 4 digital outputs, 500 mA, max. 1.25 kHz	
8BAC0132.000-1	ACOPOSmulti plug-in module, 4 analog inputs $\pm 10$ V	
8BAC0133.000-1	ACOPOSmulti plug-in module, 3 RS422 outputs for ABR encoder emulation, 1 MHz	
	<b>POWERLINK/Ethernet cables</b>	
X20CA0E61.00020	POWERLINK/Ethernet connection cable, RJ45 to RJ45, 0.2 m	
X20CA0E61.00025	POWERLINK/Ethernet connection cable, RJ45 to RJ45, 0.25 m	
X20CA0E61.00030	POWERLINK/Ethernet connection cable, RJ45 to RJ45, 0.3 m	
X20CA0E61.00035	POWERLINK/Ethernet connection cable, RJ45 to RJ45, 0.35 m	
X20CA0E61.00050	POWERLINK/Ethernet connection cable, RJ45 to RJ45, 0.5 m	
X20CA0E61.00100	POWERLINK/Ethernet connection cable, RJ45 to RJ45, 1 m	
	<b>Shield component sets</b>	
8SCS001.0000-00	ACOPOSmulti shield component set: 1x shield plate 4x type 1, 1x hose clamp, B 9 mm, D 12-22 mm	
8SCS002.0000-00	ACOPOSmulti shield component set: 1x clamping plate, 2x clamp D 4-13.5 mm, 2x screws	
8SCS003.0000-00	ACOPOSmulti shield component set: 1x shield mounting plate 4x 45°, 8x screws	
8SCS004.0000-00	ACOPOSmulti shield component set: 1x shield plate 4x type 0, 2x hose clamps, B 9 mm, D 32-50 mm	
8SCS010.0000-00	ACOPOSmulti shield component set: 1x ACOPOSmulti holding plate SK14-20, 1x shield connection clamp SK20	
	<b>Terminal blocks</b>	
8TB2104.203L-00	4-pin screw clamp terminal block, 1-row, pitch: 5.08 mm, label 3: T- T+ B- B+, coding L: 1010	
8TB2106.2010-00	6-pin screw clamp terminal block, 1-row, pitch: 5.08 mm, label 1: Numbered consecutively	
8TB2106.2210-00	Push-in terminal block 6-pin, 1-row, spacing: 5.08 mm, label 1: numbered consecutively	
8TB2108.2010-00	8-pin screw clamp terminal block, 1-row, pitch: 5.08 mm, label 1: Numbered consecutively	

Table 1: 8BVI0660HWSA.008-1 - Order data

### 3 Technical data

Order number	8BVI0660HWSA.008-1
<b>General information</b>	
B&R ID code	0x2C27
Cooling and mounting type	Wall mounting
Slots for plug-in modules	2 <sup>1)</sup>
Certifications	
CE	Yes
Functional safety <sup>2)</sup>	Yes (openSAFETY)
UL	cULus E225616 Power conversion equipment
<b>DC bus connection</b>	
Voltage	
Nominal	750 VDC
Continuous power consumption <sup>3)</sup>	48.8 kW
Power dissipation depending on switching frequency <sup>4)</sup>	
Switching frequency 5 kHz	In preparation
Switching frequency 10 kHz	In preparation
Switching frequency 20 kHz	In preparation
DC bus capacitance	1980 µF
Variant	ACOPOSmulti backplane
<b>24 VDC power supply</b>	
Input voltage	25 VDC ±1.6%
Input capacitance	32.9 µF
Max. power consumption	25 W + P <sub>SMC1</sub> + P <sub>SLOT2</sub> + P <sub>24 V Out</sub> + P <sub>HoldingBrake</sub> <sup>5)</sup>
Variant	ACOPOSmulti backplane
<b>24 VDC output</b>	
Quantity	2
Output voltage	
DC bus voltage (U <sub>DC</sub> ): 260 to 315 VDC	25 VDC * (U <sub>DC</sub> /315)
DC bus voltage (U <sub>DC</sub> ): 315 to 800 VDC	24 VDC ±6%
Fuse protection	250 mA (slow-blow) electronic, automatic reset
<b>Motor connection <sup>6)</sup></b>	
Quantity	1
Continuous power per motor connection <sup>3)</sup>	48 kW
Continuous current per motor connection <sup>3)</sup>	66 A <sub>eff</sub>
Reduction of continuous current depending on switching frequency <sup>7)</sup>	
Switching frequency 5 kHz	1.4 A/K (starting at 41°C) <sup>8)</sup>
Switching frequency 10 kHz	0.92 A/K (starting at -5°C) <sup>9)</sup>
Switching frequency 20 kHz	0.56 A/K (starting at -90°C) <sup>9)</sup>
Reduction of continuous current depending on installation elevation	
Starting at 500 m above sea level	6.6 A <sub>eff</sub> per 1000 m
Peak current	132 A <sub>eff</sub>
Nominal switching frequency	5 kHz
Possible switching frequencies <sup>10)</sup>	5 / 10 / 20 kHz
Insulation stress of the connected motor per IEC TS 60034-25:2004 <sup>11)</sup>	Limit value curve A
Protective measures	
Overload protection	Yes
Short circuit and ground fault protection	Yes
Max. output frequency	598 Hz <sup>12)</sup>
Variant	
U, V, W, PE	M8 threaded bolts
Shield connection	Yes
Connection cross section range	
Flexible and fine-stranded wires	--- <sup>13)</sup>
Terminal cable cross section dimension of shield connection	12 to 50 mm <sup>14)</sup>
Max. motor line length depending on switching frequency	
Switching frequency 5 kHz	25 m
Switching frequency 10 kHz	25 m
Switching frequency 20 kHz	25 m
<b>Motor holding brake connection</b>	
Quantity	1
Output voltage <sup>15)</sup>	24 VDC +5.8% / -0.5% <sup>16)</sup>
Continuous current	4.2 A
Max. internal resistance	0.15 Ω
Extinction potential	Approx. 30 V
Max. extinction energy per switching operation	3 Ws

Table 2: 8BVI0660HWSA.008-1 - Technical data

Order number	8BVI0660HWSA.008-1
Max. switching frequency	0.5 Hz
Protective measures	
Overload and short-circuit protection	Yes
Open-circuit monitoring	Yes
Undervoltage monitoring	Yes
Response threshold for open-circuit monitoring	Approx. 0.5 A
Response threshold for undervoltage monitoring	24 VDC -2% / -4%
<b>Encoder interfaces</b> <sup>17)</sup>	
Quantity	1
Type	SinCos
Connections	15-pin female DSUB connector
Status indicators	UP/DN LEDs
Electrical isolation	
Encoder - ACOPOSmulti	No
Encoder monitoring	Yes
Max. encoder cable length	50 m <sup>18)</sup>
Encoder power supply	
Output voltage	5 V ±5% <sup>19)</sup>
Load capacity	300 mA <sup>20)</sup>
Sense lines	2, compensation of max. 2 x 0.7 V
Protective measures	
Short-circuit proof	Yes
Overload-proof	Yes
Synchronous serial interface	
Signal transmission	RS485
Data transfer rate	781.25 kbit/s
Sine/Cosine inputs	
Signal transmission	Differential signals, symmetrical
Differential voltage	
In motion	0.5 to 1.35 V <sup>21)</sup>
At standstill	0.8 to 1.35 V <sup>22)</sup>
Differential voltage deviation per signal period	±10% <sup>23)</sup>
Common-mode voltage	Max. ±7 V
Terminating resistor	120 Ω
Max. input frequency	200 kHz
Signal frequency (-5 dB)	<300 kHz
Signal frequency (-3 dB)	DC up to 200 kHz
ADC resolution	12-bit
Reference input	
Signal transmission	Differential signal, symmetrical
Differential voltage for low	≤0.2 V
Differential voltage for high	≥0.2 V
Common-mode voltage	Max. -5 V to +9 V
Terminating resistor	120 Ω
Position	
Resolution @ 1 V <sub>SS</sub> <sup>24)</sup>	Number of encoder lines * 5700
Accuracy <sup>25)</sup>	---
Noise <sup>25)</sup>	---
Max. power consumption per encoder interface	$P_{SMC}[W] = 25 V * (0.376 A + 0.35 * I_{Encoder}[A])$ <sup>26)</sup>
<b>Trigger inputs</b>	
Quantity	2
Circuit	Sink
Electrical isolation	
Input - Inverter module	Yes
Input - Input	Yes
Input voltage	
Nominal	24 VDC
Maximum	30 VDC
Switching threshold	
Low	<5 V
High	>15 V
Input current at nominal voltage	Approx. 10 mA
Switching delay	
Rising edge	52 μs ±0.5 μs (digitally filtered)
Falling edge	53 μs ±0.5 μs (digitally filtered)
Modulation compared to ground potential	Max. ±38 V
<b>Electrical properties</b>	
Discharge capacitance	0.44 μF

Table 2: 8BVI0660HWSA.008-1 - Technical data

Order number	8BVI0660HWSA.008-1
<b>Operating conditions</b>	
Permissible mounting orientations	
Hanging vertically	Yes
Horizontal, face up	Yes
Standing horizontally	No
Installation elevation above sea level	
Nominal	0 to 500 m
Maximum <sup>27)</sup>	4000 m
Pollution degree per EN 61800-5-1	2 (non-conductive pollution)
Overvoltage category per EN 61800-5-1	III
Degree of protection per EN 60529	IP20 <sup>28)</sup>
<b>Ambient conditions</b>	
Temperature	
Operation	
Nominal	5 to 40°C
Maximum <sup>29)</sup>	55°C
Storage	
Transport	-25 to 70°C
Relative humidity	
Operation	
Storage	5 to 85%
Transport	Max. 95% at 40°C
<b>Mechanical properties</b>	
Dimensions <sup>30)</sup>	
Width	213.5 mm
Height	317 mm
Depth	
Wall mounting	263 mm
Weight	Approx. 10.9 kg
Module width	4

Table 2: 8BVI0660HWSA.008-1 - Technical data

- SLOT 2 is available. SLOT 1 of the ACOPOSmulti module is occupied by the SafeMOTION module.
- Achievable safety classifications (safety integrity level, safety category, performance level) are documented in the user's manual (section "Safety technology").
- Valid under the following conditions: 750 VDC DC bus voltage, 5 kHz switching frequency, 40°C ambient temperature, installation elevation <500 m above sea level, no derating due to cooling type.
- $I_M$  ... Current on motor connection X5A [A<sub>eff</sub>]
- $P_{SMC1}$  ... Max. power consumption  $P_{SMC}$  [W] of the SafeMOTION module in SLOT1 (see section "Encoder interfaces").  
 $P_{SLOT2}$  ... Max. power consumption  $P_{BAC}$  [W] of the plug-in module in SLOT2 (see the technical data for the respective plug-in module).  
 $P_{24V Out}$  ... Power [W] that is output to the connections X2/+24 V Out 1 and X2/+24 V Out 2 on the module (max. 10 W).
- Only B&R 8BCM motor cables are permitted to be used for wiring the motor connections!
- Valid under the following conditions: 750 VDC DC bus voltage. The temperature specifications refer to the ambient temperature.
- Value for the nominal switching frequency.
- The module cannot supply the full continuous current at this switching frequency. This unusual value for the ambient temperature, at which derating of the continuous current must be taken into account, ensures that the derating of the continuous current can be determined in the same manner as at other switching frequencies.
- B&R recommends operating the module at its nominal switching frequency. Operating the module at a higher switching frequency for application-specific reasons reduces the continuous current and increases CPU utilization.
- If necessary, the stress of the motor isolation system can be reduced by an additional externally wired dv/dt choke. For example, the RWK 305 three-phase dv/dt choke from Schaffner ([www.schaffner.com](http://www.schaffner.com)) can be used. IMPORTANT: Even when using a dv/dt choke, it is necessary to ensure that an EMC-compatible, low inductance shield connection is used!
- The module's electrical output frequency (SCTRL\_SPEED\_ACT \* MOTOR\_POLEPAIRS) is monitored to protect against dual use in accordance with Regulation (EC) 428/2009 | 3A225. If the electrical output frequency of the module exceeds the limit value of 598 Hz uninterrupted for more than 0.5 s, then the current movement is aborted and error 6060 is output ("Power unit: Limit speed exceeded").
- The connection is made with cable lugs for M8 (0.32") threaded bolts. The nominal cross section of the cable lug must match the cross section of the conductor to be connected in the particular application.
- The maximum diameter that can be clamped depends on the shield component set.
- During configuration, it is necessary to check if the minimum voltage can be maintained on the holding brake with the intended wiring. For the operating voltage range of the holding brake, see the user documentation for the motor being used.
- The specified value is only valid under the following conditions:  
- The 24 VDC power supply for the module is provided by an 8BOC auxiliary supply module located on the same mounting plate.  
- Connection of connectors S1 and S2 (activation of the external holding brake) by a jumper with a maximum length of 10 cm.  
If the 24 VDC power supply for the module is applied to the mounting plate using an 8BVE expansion module, then the output voltage is reduced because of voltage drops on the expansion cable. In this case, undervoltage monitoring must be disabled.  
If jumpers longer than 10 cm are used to connect connectors S1 and S2, then the output voltage is reduced due to voltage drops on the jumpers.
- Only shielded lines are permitted to be used for wiring.  
The stranded wire for the analog interface (Sin, nSin, Cos, nCos, Ref, nRef) and the digital interface (T, nT, D, nD) must be twisted pair with a wave impedance of 120 Ω ±10%.  
Additional shielding of the analog interface is recommended.
- The maximum permissible cable length is 50 m.
- During the switch-on procedure for the encoder supply voltage (2 seconds), the monitoring limit for the power supply is increased from 5.25 V to 6 V. In this phase, overvoltages up to 6 V are not detected.  
A short-term overvoltage of maximum 6 V is not permitted to damage the encoder electronics in any way.  
Undervoltage on the encoder power supply must result in a sine or cosine signal outside specifications.
- An actual reserve of 12 mA exists for the terminating resistor.
- The sine-cosine output signals from the measuring instrument are checked by the evaluation circuit using pointer length monitoring.  
The pointer length  $z = 2 \sqrt{(\text{Sin} - \text{nSin})^2 + (\text{Cos} - \text{nCos})^2}$  is monitored according to the specified limits.

- 22) The sine-cosine output signals from the measuring instrument are checked by the evaluation circuit using pointer length monitoring. The pointer length  $z = 2 \sqrt{(\sin - n\sin)^2 + (\cos - n\cos)^2}$  is also monitored according to the specified limits from the time the evaluation circuit is switched on until a signal period has passed.
- 23) The sine-cosine output signals from the measuring instrument are checked by the evaluation circuit using pointer length monitoring. The pointer length  $z = 2 \sqrt{(\sin - n\sin)^2 + (\cos - n\cos)^2}$  is permitted to deviate by a maximum of  $\pm 10\%$  per signal period.
- 24) This value does not correspond to the encoder resolution that must be configured in Automation Studio ( $16384 \cdot \text{number of encoder lines}$ ).
- 25) Limited by the encoder in practice.
- 26)  $I_{\text{Encoder}}$  ... Max. current consumption of the connected encoder [A].
- 27) Continuous operation at an installation elevation of 500 m to 4,000 m above sea level is possible taking the specified reduction of continuous current into account.
- 28) This value only applies in its delivered state (SLOT2 of the module is sealed by a slot cover / shield plate). If SLOT2 on the module is not sealed, then the level of protection is reduced to IP10. It is important to note that a 8SCS005.0000-00 shield set (slot cover / shield plate) or plug-in module must always be inserted!
- 29) Continuous operation at an ambient temperature of 40°C to max. 55°C is possible when taking the specified reduction of continuous torque into account, but this results in premature aging of components.
- 30) These dimensions refer to the actual device dimensions including the respective mounting plate. Additional spacing above and below the devices must be taken into account for mounting, connections and air circulation.

## 4 Overload characteristics

The continuous current for the module is permitted to be exceeded for a short time during operation (dynamic overload).

### Overload response: WARNING

If the maximum overload time is exceeded, the module outputs a warning (WARNING).

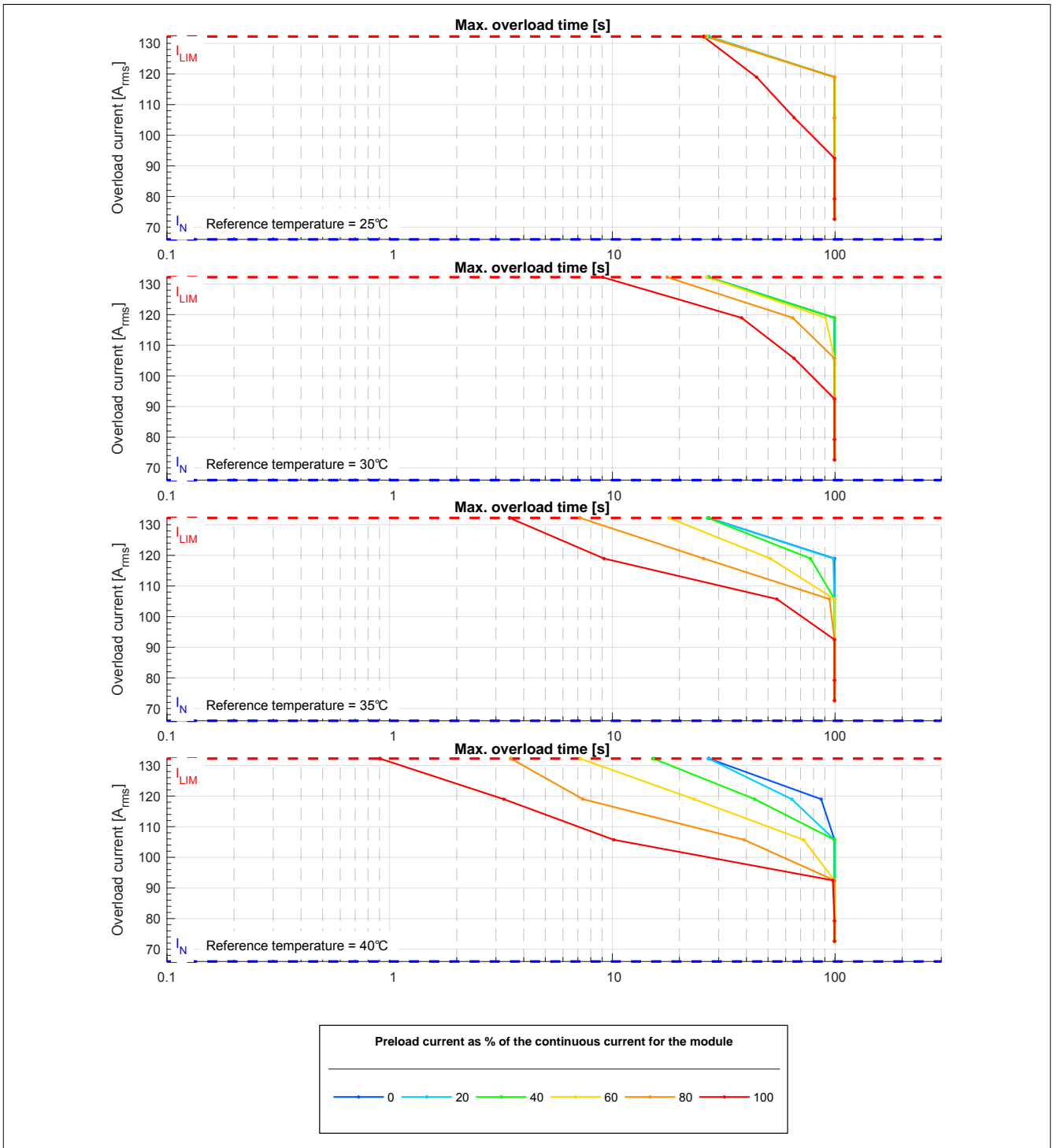

Figure 1: 8BVI0660HWSx.0x8-1 - Overload characteristics, overload response - WARNING

$I_N$	Continuous current of the module [A <sub>rms</sub> ]
$I_{LIM}$	Peak current of the module [A <sub>rms</sub> ]
Mounting type:	Wall mounting
DC bus voltage:	750 V
Switching frequency:	5 kHz
Rotary frequency of current indicator:	20 Hz
Reference temperature:	Ambient temperature of the module

### Overload response ERROR + STOP

When the module exceeds the maximum overload duration, it outputs an error and executes a movement stop with current limiting (ERROR + STOP).

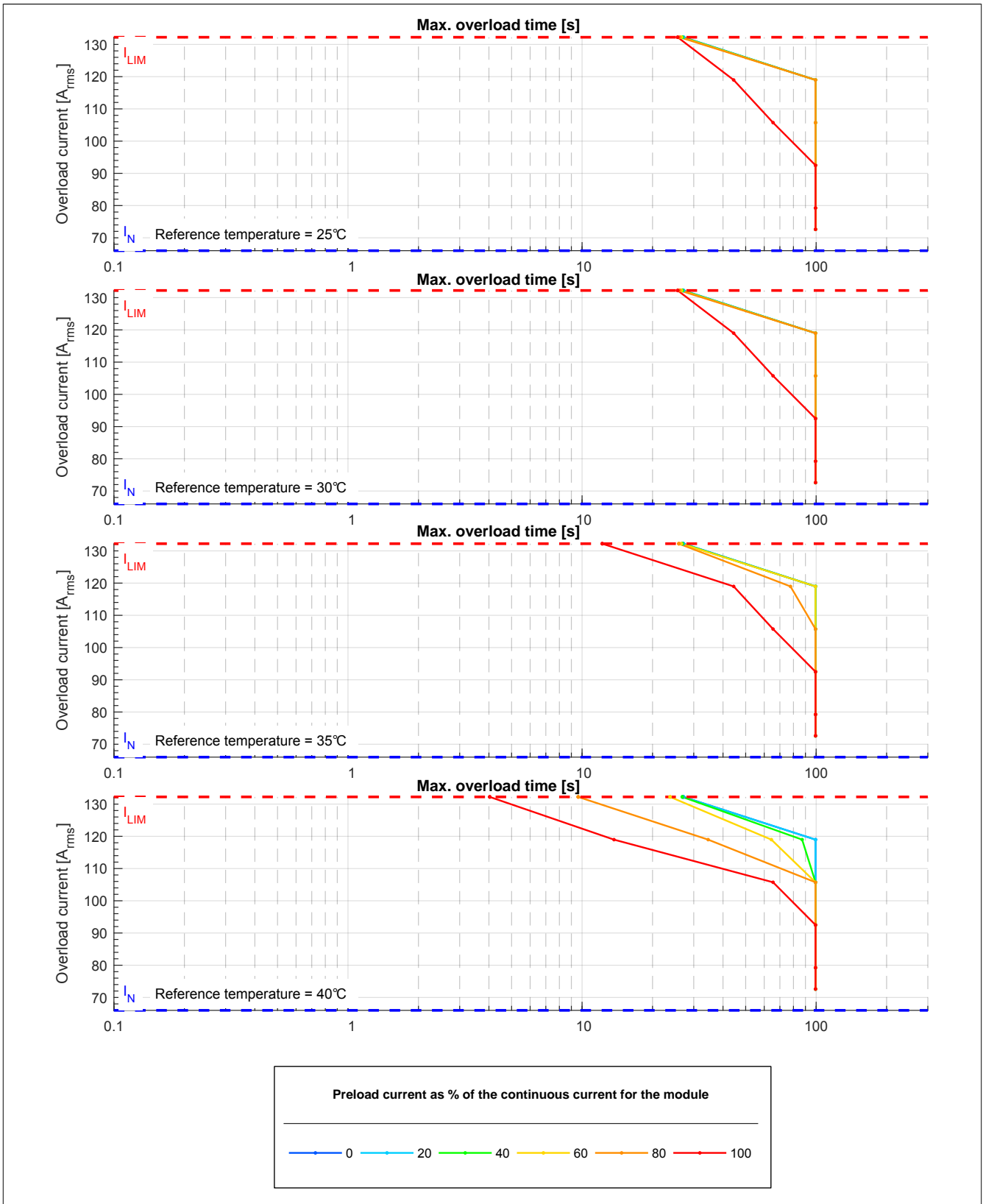

Figure 2: 8BVI0660HWSx.0x8-1 - Overload characteristics, overload response - ERROR+STOP

$I_N$  Continuous current of the module [A<sub>rms</sub>]  
 $I_{LIM}$  Peak current of the module [A<sub>rms</sub>]  
 Mounting type: Wall mounting  
 DC bus voltage: 750 V  
 Switching frequency: 5 kHz  
 Rotary frequency of current 20 Hz  
 indicator:  
 Reference temperature: Ambient temperature of the module

## 5 Dimension diagram and installation dimensions

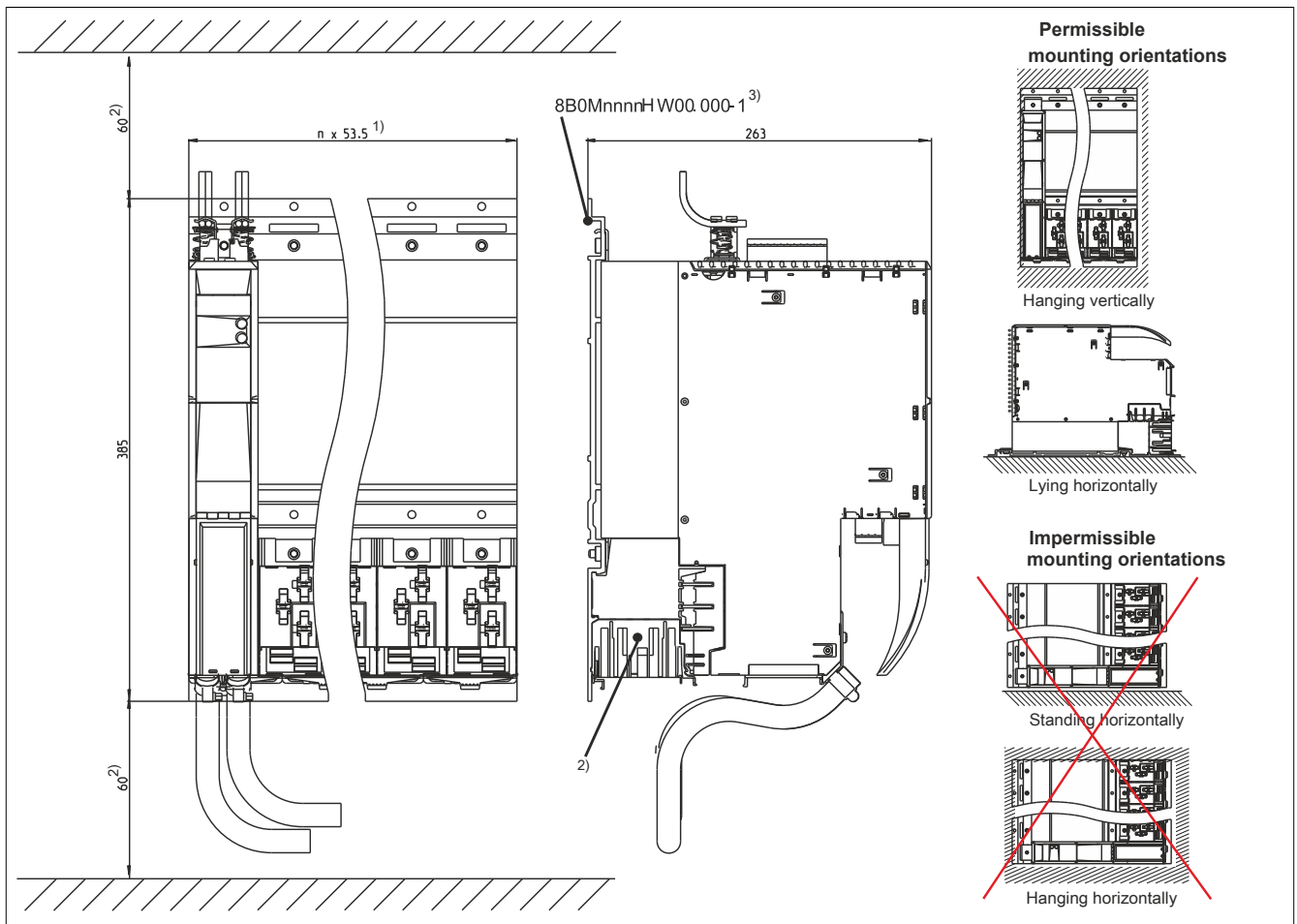

Figure 3: Dimension diagram and installation dimensions

- 1) n... Number of width units on the mounting plate
- 2) For sufficient air circulation, a clearance of at least 60 mm must be provided above the mounting plate and below the module. **To ensure that the fan modules in the mounting plate can be replaced easily, at least 250 mm clearance must be available below the module.**
- 3) nnnn indicates the number of slots (e.g. 0160 refers to 16 slots).

## 6 Wiring: Safe 4x width inverter modules (1-axis modules)

### 6.1 ACOPOSmulti SafeMOTION SinCos - Pinout overview

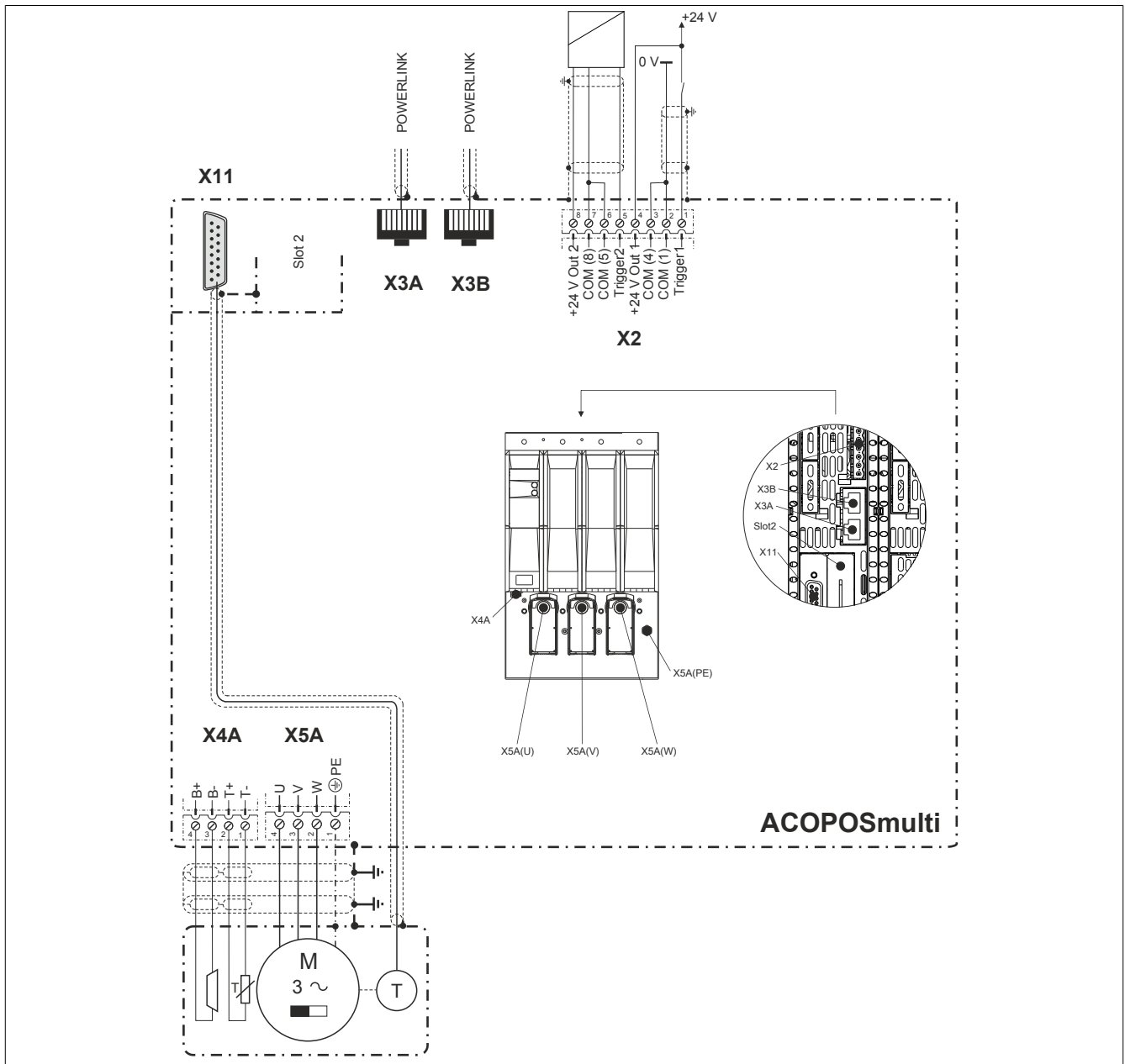

Figure 4: Pinout overview

### 6.2 Connector X2 - Pinout

X2		Pin	Name	Function
	1	1	Trigger 1	Trigger 1
	2	2	COM (1)	Trigger 1 0 V
	3	3	COM (2)	+24 V output 1 0 V
	4	4	+24 V Out 1	+24 V output 1
	5	5	Trigger 2	Trigger 2
	6	6	COM (5)	Trigger 2 0 V
	7	7	COM (8)	+24 V output 2 0 V
	8	8	+24 V Out 2	+24 V output 2

Table 3: Connector X2 - Pinout

### 6.3 Connectors X3A, X3B - Pinout

X3A, X3B	Pin	Name	Function
	1	RXD	Receive signal
	2	RXD\	Receive signal inverted
	3	TXD	Transmit signal
	4	Shield	Shield
	5	Shield	Shield
	6	TXD\	Transmit signal inverted
	7	Shield	Shield
	8	Shield	Shield

Table 4: X3A, X3B connectors - Pinout

### 6.4 Connector X4A - Pinout

X4A	Name	Function
	T-	Axis 1: Temperature sensor -
	T+	Axis 1: Temperature sensor +
	B-	Axis 1: Brake -
	B+	Axis 1: Brake +

Table 5: Connector X4A - Pinout

## Danger!

A short circuit of SBC output B+ against 24 V results in state FUNCTIONAL FAIL SAFE being enabled. This means that safe pulse disabling is enabled. The brake always remains switched on / released, however, due to the short circuit to 24 V!

This can result in dangerous situations since the motor holding brake cannot brake, prevent the spin-out movement or prevent the unbraked lowering movement when loads are suspended!

A short circuit of SBC output B+ against 24 V must be prevented by suitable wiring measures!

## Danger!

The following applies to the SBC output:

- The SBC output is not permitted to be wired across modules!
- The SBC output is not permitted to be wired as an open emitter!
- The SBC output is not permitted to be wired as an open collector!

## Danger!

Only an output voltage of  $\leq 5$  V can be ensured for the safe motor holding brake output in the switched-off state. When selecting the motor holding brake, the user must ensure that the required braking torque is achieved with a voltage of 5 V applied.

## Information:

The transistors of the SBC output stage are tested cyclically. When the output channels are active, this test emits low pulses on the output with a maximum length of 600  $\mu$ s.

This must be taken into account when choosing the motor holding brake!

## Danger!

The connections for the motor temperature sensors and the motor holding brake are safely isolated circuits. As a result, only devices or components that have at least safe isolation per IEC 60364-4-41 or EN 61800-5-1 are permitted to be connected to these connections.

## Caution!

If B+ and B- are swapped when connecting the permanent magnet holding brakes, then the brakes cannot be opened! ACOPOSmulti inverter modules cannot determine if a holding brake is connected with reverse polarity!

## Warning!

Temperature sensors are only permitted to be connected to the X4A/T+ and X4A/T- connectors on an ACOPOSmulti module under the following conditions:

- SLOT1 of the ACOPOSmulti module does not contain an ACOPOSmulti plug-in module to which a temperature sensor is connected on the T+ and T- connections.

Otherwise, the temperature monitoring functions on the ACOPOSmulti module may become ineffective, which in extreme cases can cause the hardware (e.g. motors) connected to the ACOPOSmulti module to be destroyed!

Connections T+ and T- are not required when using 8BCHxxxx hybrid motor cables.

### 6.5 X5A - Pinout

X5A	Name	Function
	1	Axis 1: Protective ground conductor
	2	Axis 1: Motor connection W
	3	Axis 1: Motor connection V
	4	Axis 1: Motor connection U

Table 6: X5A - Pinout

## Information:

Only B&R 8BCM motor cables are permitted to be used for wiring the motor connections!

### Motor connections U, V, W - Cable installation

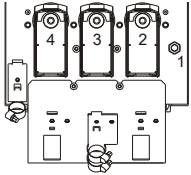
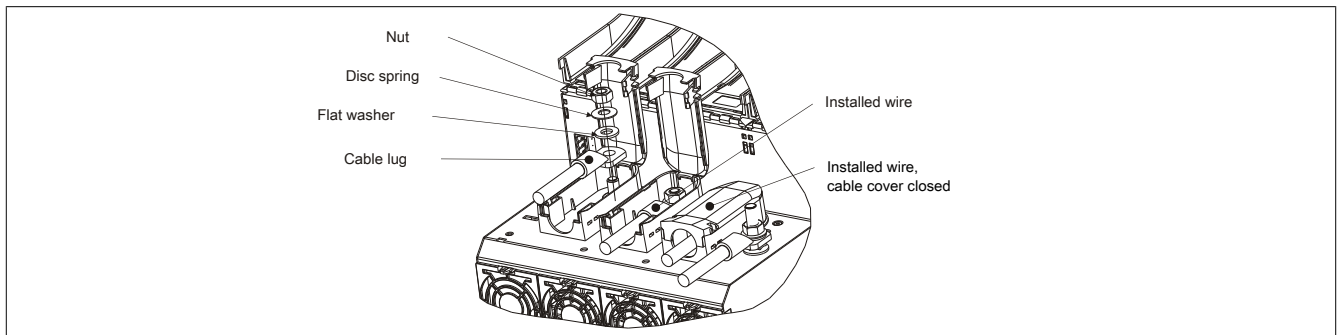

Figure 5: X5A - Cable installation

**PE connection (1-wire) - Cable installation**

Table 7: PE connection (1-wire) - Cable installation

**PE connection (3-wire) - Cable installation**

Table 8: PE connection (3-wire) - Cable installation

## 6.6 SafeMOTION module SinCos - Pinout

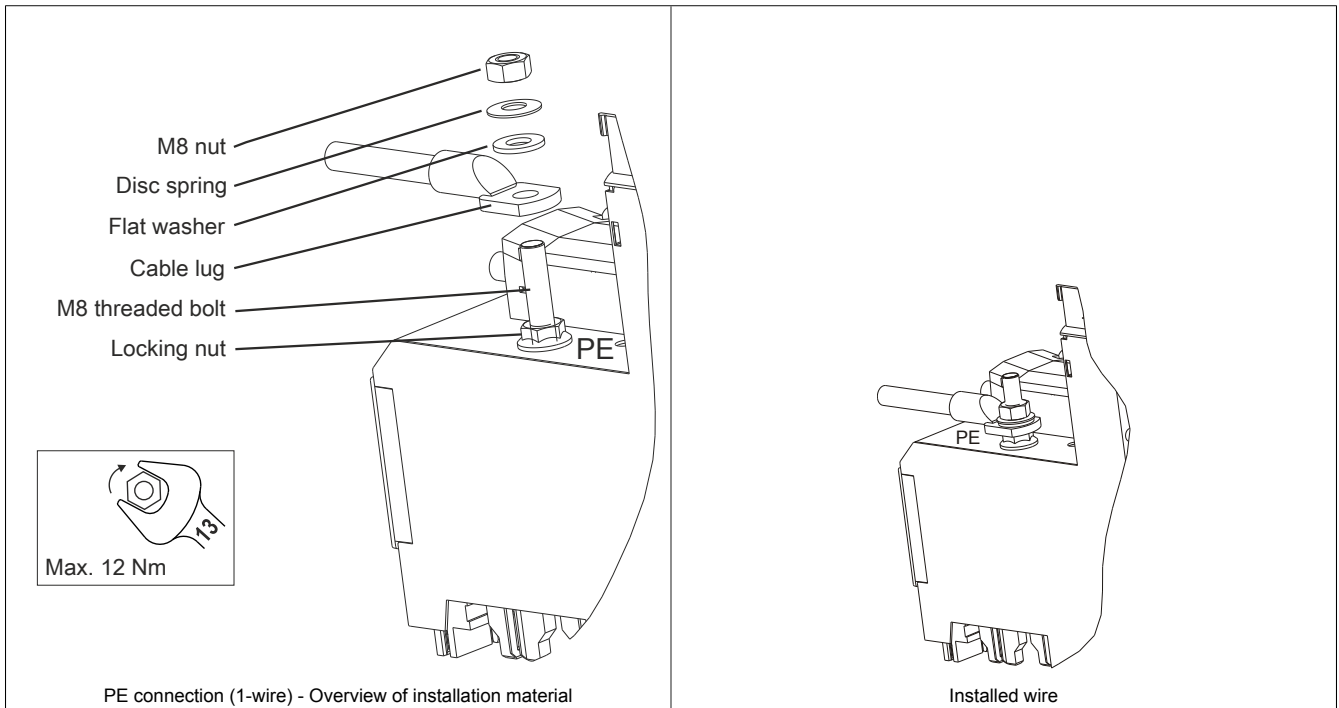
Figure	X11	Pin	Name	Function
		1	A	Channel A/SIN
		2	COM	Ground
		3	B	Channel B/COS
		4	+5 V	Encoder power supply +
		5	D	Data
		6	---	---
		7	R\	Reverence impulse inverted / nREF
		8	T	Clock
		9	A\	Channel A inverted / nSIN
		10	Sense COM	Sense mass
		11	B\	Channel B inverted / nCOS
		12	Sense +5 V	Sense input +5 V
		13	D\	Data inverted
		14	R	Reverence pulse / REF
		15	T\	Clock inverted

### Information:

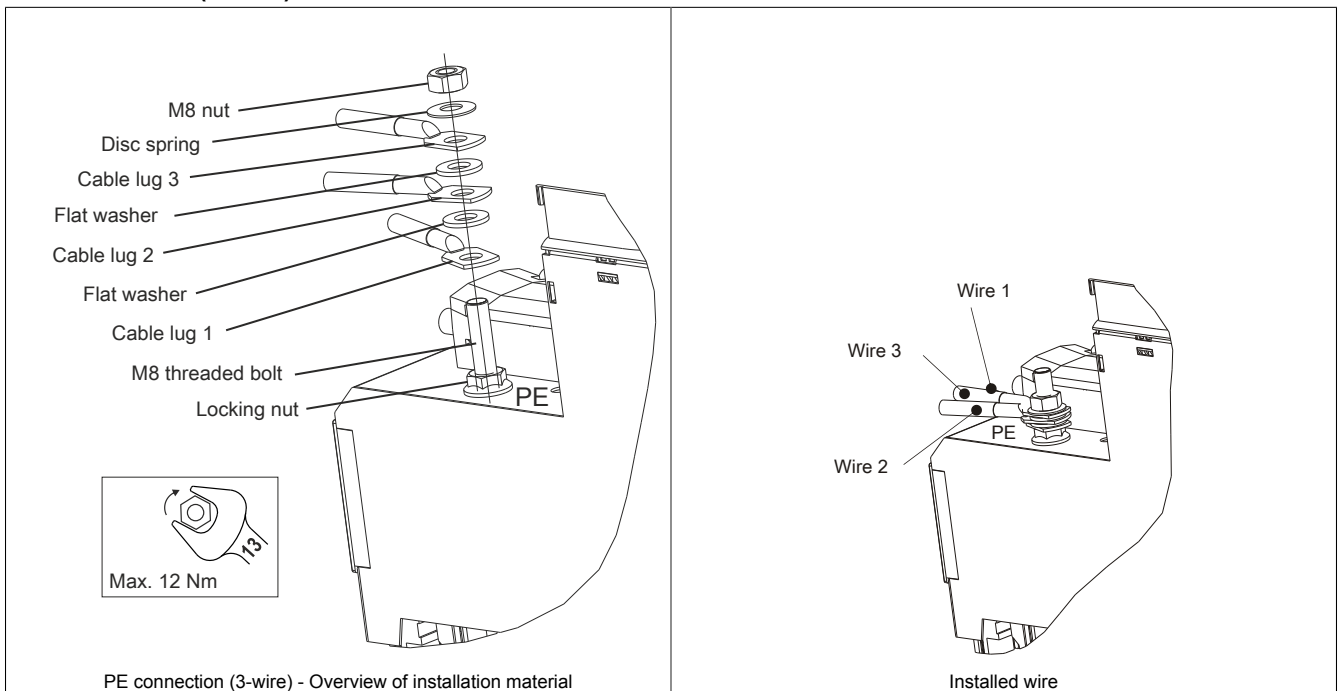
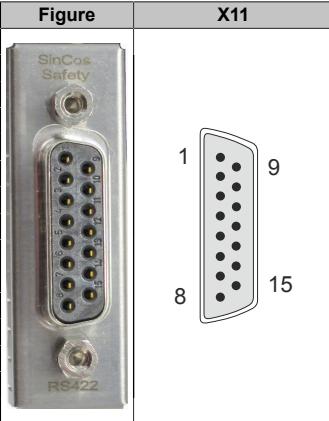
The SafeMOTION module cannot be replaced! The SafeMOTION module and the ACOPOSmulti SafeMOTION inverter module together form a single unit. In the event of an error, the entire module must be replaced.