

THIS DRAWING IS UNPUBLISHED. RELEASED FOR PUBLICATION ,19 .
 © COPYRIGHT 19 BY AMP INCORPORATED. ALL RIGHTS RESERVED.

LOC	DIST	REVISIONS			
P	LTR	DESCRIPTION	DATE	DWN	APVD
G	14	H	REVISED PER 0L20-0133-96	14NOV96	DKS MJS

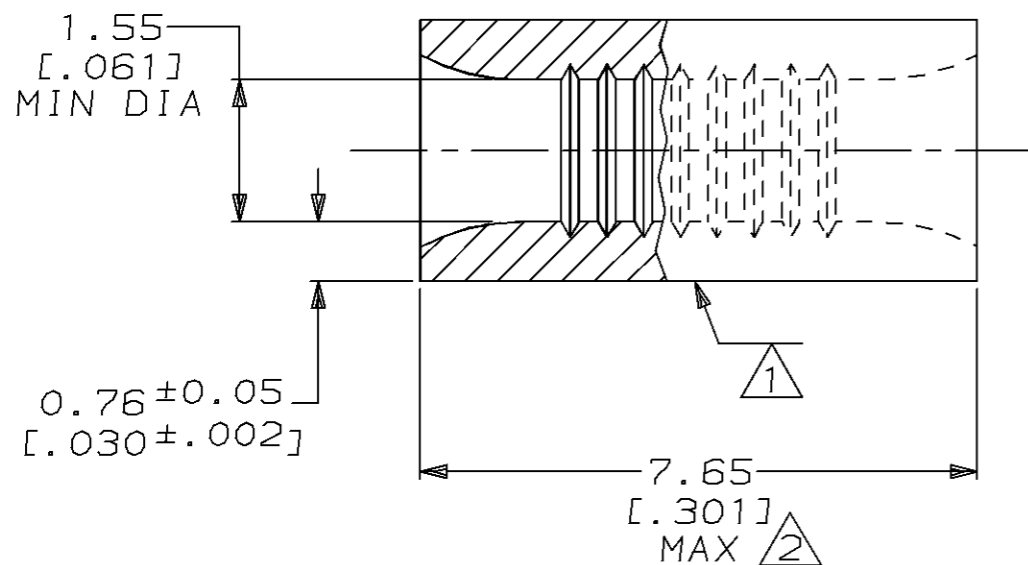
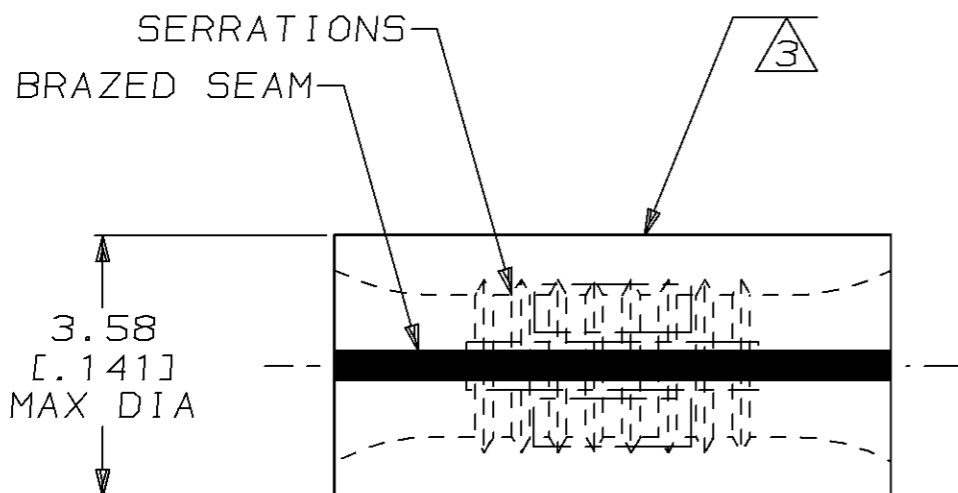

AMP WIRE RANGE	E13288 Listed
22-16 AWG SOLID OR STRANDED	NOT APPLICABLE
LR7189 Certified	MILITARY P/N AND CLASS
NOT APPLICABLE	NOT APPLICABLE

- ① STAMP AMP 22-18 APPROX AS SHOWN
22-16 SPLICES ARE STAMPED WITH 22-18 IN
ACCORDANCE WITH MILITARY SPEC MIL-T-7928
COMMERCIAL WIRE RANGE IS 22-16
- ② MAXIMUM LENGTH DOES NOT INCLUDE
MANUFACTURING TABS
- ③ WIRE BARREL COLOR CODED ORANGE
TO DENOTE NICKEL MATERIAL

NONE	322326-1
REQD	322326
③ COLOR CODING	AMP PART NUMBER

AMP INCORPORATED CUSTOMER SERVICE SYSTEMS

FOR ADDITIONAL PRODUCT INFORMATION OR COPIES OF DRAWINGS AND TECHNICAL DOCUMENTS	PRODUCT INFORMATION CENTER 1-800-522-6752
FOR APPLICATION TOOLING INFORMATION	TOOLING ASSISTANCE CENTER 1-800-722-1111
FOR ORDER ENTRY	1-800-526-5142

RECOMMENDED OPERATING TEMPERATURE: 649°C MAX
VOLTAGE RATING: NOT APPLICABLE
WIRE CROSS SECTIONAL AREA RANGE: 0.26-1.65mm ² [509-3,250] CIR MILS SOLID OR STRANDED

THIS DRAWING IS A CONTROLLED DOCUMENT.

DIMENSIONS: mm [INCHES]	TOLERANCES UNLESS OTHERWISE SPECIFIED:
	0 PLC ±-
	1 PLC ±-
	2 PLC ±-
	3 PLC ±-
	4 PLC ±-
	ANGLES ±-
MATERIAL NICKEL PER ASTM B-162 ANNEALED	FINISH -

DWN DK SCHRUM 14NOV96	AMP Incorporated Harrisburg, PA 17105-3608
CHK MJ SPICER 19NOV96	
APVD JL MECKLEY 19NOV96	
PRODUCT SPEC -	
APPLICATION SPEC -	NAME SPLICE, PARALLEL, HIGH TEMPERATURE, STARTO-THERM™
WEIGHT -	SIZE A3
CUSTOMER DRAWING	CAGE CODE 00779
	DRAWING NO G-322326
	SCALE 10:1
	SHEET 1 OF 1
	REV H