

PCB LAYOUT: COMPONENT SIDE  
RECOMMENDED PCB THICKNESS: .062/157

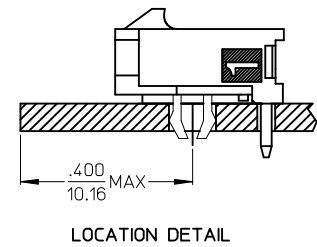

LOCATION DETAIL  
SEE NOTE #6

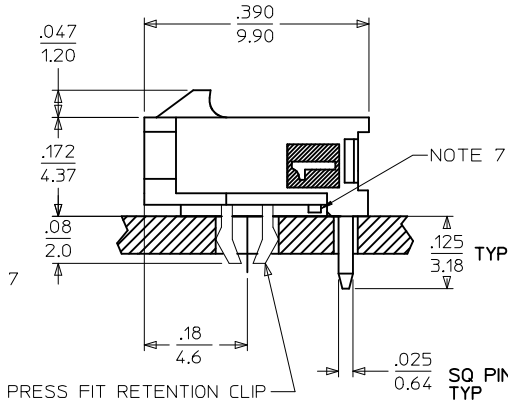
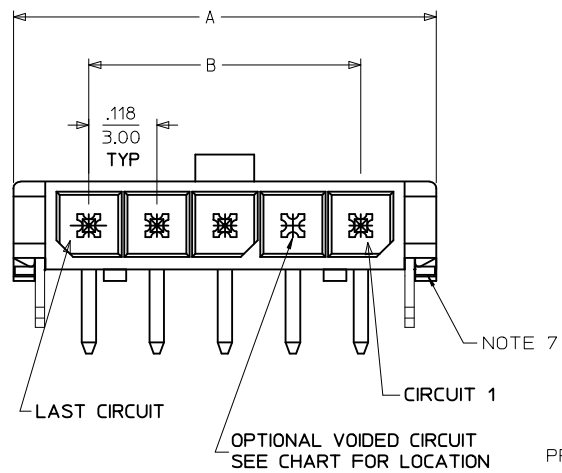
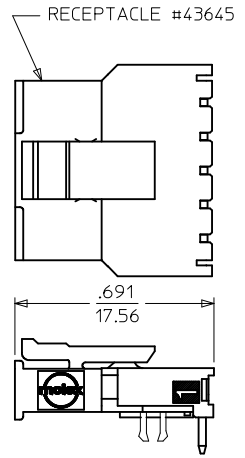

MATED MICRO FIT CONNECTOR

CKTS	DIM A	DIM B	DIM C
2	.380 / 9.65	.118 / 3.00	.287 / 7.30
3	.498 / 12.65	.236 / 6.00	.405 / 10.30
4	.616 / 15.65	.354 / 9.00	.524 / 13.30
5	.734 / 18.64	.472 / 12.00	.642 / 16.30
6	.852 / 21.64	.591 / 15.00	.760 / 19.30
7	.970 / 24.64	.709 / 18.00	.878 / 22.30
8	1.088 / 27.64	.827 / 21.00	.996 / 25.30
9	1.206 / 30.63	.945 / 24.00	1.114 / 28.30
10	1.325 / 33.66	1.063 / 27.00	1.232 / 31.30
11	1.443 / 36.65	1.181 / 30.00	1.350 / 34.30
12	1.561 / 39.65	1.299 / 33.00	1.469 / 37.30

NOTES:

- HOUSING MATERIAL: LIQUID CRYSTAL POLYMER, GLASS FILLED, UL94V-0, COLOR: BLACK  
TERMINAL MATERIAL: BRASS ALLOY
- FINISH:  
A = .000100/(0.00254) MIN. BRIGHT TIN OVER  
.000050/(0.00127) MIN. NICKEL OVERALL  
B = .000015/(0.00038) MIN. SELECT GOLD IN CONTACT AREA  
.000100/(0.00254) MIN. SELECT MATTE TIN ON SOLDER TAILS  
BOTH OVER .000050/(0.00127) MIN. NICKEL OVERALL  
C = .000030/(0.00076) MIN. SELECT GOLD IN CONTACT AREA  
.000100/(0.00254) MIN. SELECT MATTE TIN ON SOLDER TAILS  
BOTH OVER .000050/(0.00127) MIN. NICKEL OVERALL  
D = .000100/(0.00254) MIN. MATTE TIN OVER  
.000050/(0.00127) MIN. NICKEL OVERALL
- PRODUCT SPECIFICATION: PS-43650
- TRAY PACKAGED : SEE MOLEX DRAWING PK-70873-0321
- MATES WITH MICRO FIT (3.0) RECEPTACLE SERIES 43645
- TO AVOID INTERFERENCE BETWEEN RECEPTACLE AND PCB, HEADER MUST BE PLACED WITHIN .400/(10.16) MAX. FROM EDGE OF PCB, AS SHOWN IN LOCATION DETAIL.
- METAL TAB MAY BE FLUSH WITH PCB.
- PART CONFORMS TO CLASS "B" REQUIREMENTS OF COSMETIC SPECIFICATION' PS-45499-002.

CKTS	FINISH A		FINISH B		FINISH C		FINISH D	
	MATERIAL NO:	VOID CKT	MATERIAL NO:	VOID CKT	MATERIAL NO:	VOID CKT	MATERIAL NO:	VOID CKT
02	43650-0203		43650-0204		43650-0205		43650-0259	
03	43650-0303		43650-0304		43650-0305		43650-0359	
04	43650-0403		43650-0404		43650-0405		43650-0459	
05	43650-0503		43650-0504		43650-0505		43650-0559	
06	43650-0603		43650-0604		43650-0605		43650-0659	
07	43650-0703		43650-0704		43650-0705		43650-0759	
08	43650-0803		43650-0804		43650-0805		43650-0859	
09	43650-0903		43650-0904		43650-0905		43650-0959	
10	43650-1003		43650-1004		43650-1005		43650-1059	
11	43650-1103		43650-1104		43650-1105		43650-1159	
12	43650-1203		43650-1204		43650-1205		43650-1259	
07	43650-1703	05					43650-1759	05

FIX CLIP GEOMETRY	QUALITY SYMBOLS
EC NO: UCP2015-4141	▽=0
DRWN:JDOX 2015/04/08	▽=0
CHKD:SSOUSEK 2015/04/08	▽=0
APPR:FSMLTH 2015/04/10	
REV	

GENERAL TOLERANCES (UNLESS SPECIFIED)

	mm	INCH
4 PLACES ±	---	---
3 PLACES ±	---	±.010
2 PLACES ±	0.25	±.014
1 PLACE ±	0.36	±---
0 PLACE ±	±	±

ANGULAR ±1/2°  
DRAFT WHERE APPLICABLE  
MUST REMAIN WITHIN DIMENSIONS

DIMENSION STYLE  
IN/MM

DRAWN BY: SAMIEC DATE: 2000/07/07  
CHECKED BY: MUELLER DATE: 2000/07/07  
APPROVED BY: EDGLEY DATE: 2000/07/07

MATERIAL NO.  
**SEE CHART**

SCALE: ---  
DESIGN UNITS: METRIC  
THIRD ANGLE PROJECTION

TITLE:  
**MICRO FIT (3.0)  
SINGLE ROW / RIGHT ANGLE  
THRU HOLE / CLIPS / TRAY**

**molex**

DOCUMENT NO.: SD-43650-002  
SHEET NO.: 1 OF 1

THIS DRAWING CONTAINS INFORMATION THAT IS PROPRIETARY TO MOLEX INCORPORATED AND SHOULD NOT BE USED WITHOUT WRITTEN PERMISSION