

PART NO.	"A" REF.	"B"±.016 (±0.41)	INTERCHANGE WITH SCANBE
RSDC-250	2.5 (63.5)	1.5 (38.1)	11633-1
RSDC-300	3.0 (76.2)	2.0 (50.8)	
RSDC-350	3.5 (88.9)	2.5 (63.5)	
RSDC-400	4.0 (101.6)	3.0 (76.2)	
RSDC-450	4.5 (114.3)	3.5 (88.9)	11633-2
RSDC-500	5.0 (127.0)	4.0 (101.6)	
RSDC-550	5.5 (139.7)	4.5 (114.3)	
RSDC-600	6.0 (152.4)	5.0 (127.0)	
RSDC-650	6.5 (164.1)	5.5 (139.7)	11633-3
RSDC-700	7.0 (177.8)	6.0 (152.4)	
RSDC-750	7.5 (190.5)	6.5 (165.1)	
RSDC-800	8.0 (203.2)	7.0 (177.8)	11633-6

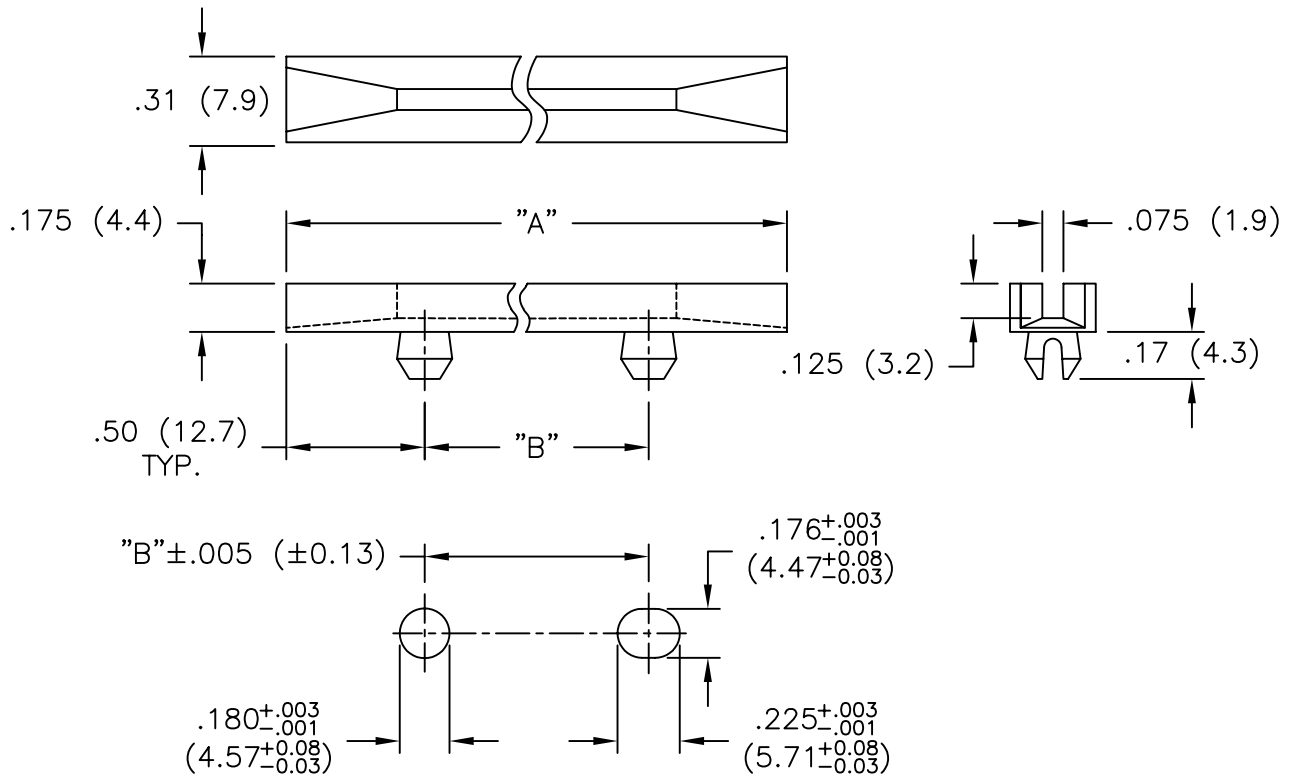

RECOMMENDED MOUNTING HOLES  
 PANEL THICKNESS: .047-.090 (1.2-2.3)

NOTES:

1. MATERIAL: NYLON 6/6 (RMS-48).
2. COLOR: NATURAL.

F	SEE ECN #831 FOR CHANGES	SM 08.09.04
E	COMPLETELY REDRAWN	SM 02.11.02
D	REM. "NO TAMPER AND RAMP" ON PRINT	JL 08.07.00
C	DIM. .225 (5.7) WAS .255 (6.5)	RS 01.25.93
B	DIM. "A" WAS REF.	RS 11.25.92
A	METRIC DIMS CORRECTED	RS 08.17.92
REV	DESCRIPTION	ENGR DATE

TITLE: SNAP-IN CARD GUIDE



DWG IN  
IN (MM)

FINAL

TOLERANCES UNLESS NOTED .XX=±.010 .XXX=±.005 FRAC=±1/64 ANG=±1°	FILE # RSDC	DWN: P.B.	APP:	PART # SEE TABLE	PRINT TYPE CA
	MAT'L: SEE NOTES	DT: 04.-05-94	DT:		
	RE: RICHCO, INC.	RICHCO INC. PO BOX 804238, CHICAGO, 60680 (773) 539-4060			