



FPAB30BH60

PFC SPM® 3 Series for Single-Phase Boost PFC

Features

- UL Certified No. E209204 (UL1557)
- 600 V - 30 A Single-Phase Boost PFC with Integral Gate Driver and Protection
- Very Low Thermal Resistance Using Al₂O₃ DBC Substrate
- Full-Wave Bridge Rectifier and High-Performance Output Diode
- Built-in NTC Thermistor for Temperature Monitoring
- Optimized for 20kHz Switching Frequency
- Isolation Rating: 2500 Vrms/min.

Applications

- Single-Phase Boost PFC Converter

Related Source

- [AN-9090 - PFC SPM 3 Series User's Guide](#)
- [AN-9091 - Boost PFC Inductor Design Guide](#)

General Description

The FPAB30BH60 is a PFC SPM® 3 module providing a fully-featured, high-performance Boost PFC (Power Factor Correction) input power stage for consumer, medical, and industrial applications. These modules integrate optimized gate drive of the built-in IGBT to minimize EMI and losses, while also providing multiple on-module protection features including under-voltage lockout, over-current shutdown, thermal monitoring, and fault reporting. These modules also feature a full-wave rectifier, and high-performance output diode for additional space savings and mounting convenience

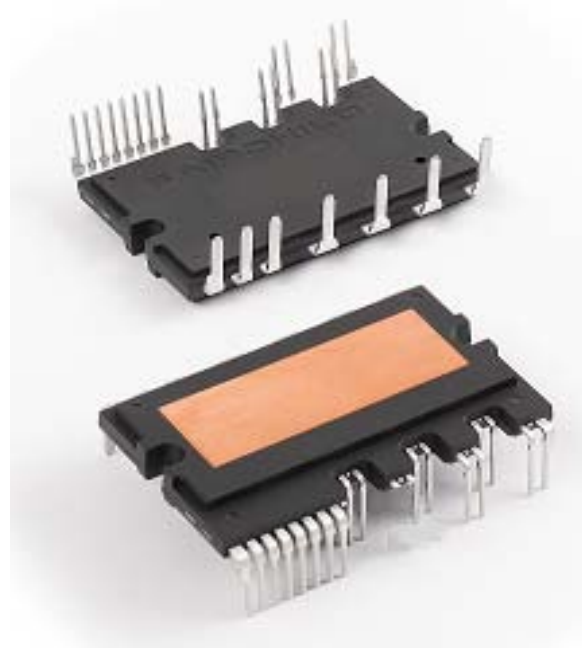

Figure 1. Package Overview

Package Marking & Ordering Information

Device	Device Marking	Package	Packing Type	Quantity
FPAB30BH60	FPAB30BH60	SPMIA-027	Rail	10

Integrated Power Functions

- PFC converter for single-phase AC / DC power conversion (please refer to Figure 3)

Integrated Drive, Protection, and System Control Functions

- For IGBTs: gate drive circuit, Over-Current Protection (OCP), control supply circuit Under-Voltage Lock-Out (UVLO) Protection
- Fault signal: corresponding to OC and UV fault
- Built-in thermistor: temperature monitoring
- Input interface: active-HIGH interface, works with 3.3 / 5 V logic, Schmitt-trigger input

Pin Configuration

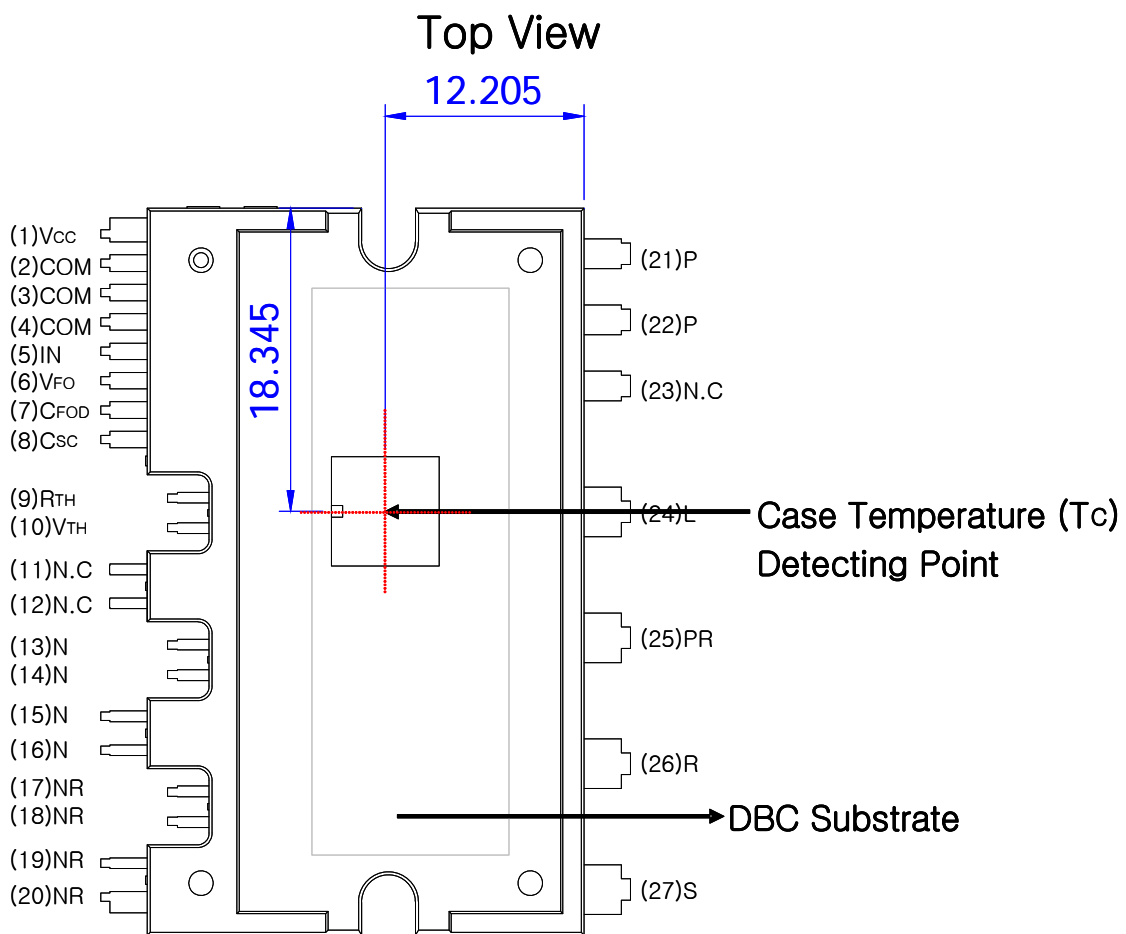

Figure 2. Top View

Notes :

1. For the measurement point of case temperature(T_c), please refer to Figure 2.

Absolute Maximum Ratings ($T_J = 25^\circ\text{C}$, unless otherwise specified.)**Converter Part**

Symbol	Item	Condition	Rating	Unit
V_i	Supply Voltage	Applied between R - S	264	V_{rms}
$V_{i(\text{Surge})}$	Supply Voltage (Surge)	Applied between R - S	500	V
V_{PN}	Output Voltage	Applied between P - N	450	V
$V_{\text{PN}(\text{Surge})}$	Output Voltage (Surge)	Applied between P - N	500	V
V_{CES}	Collector - Emitter Voltage		600	V
I_{FSM}	Peak Forward Surge Current	Single Half Sine-Wave	250	A
I_i	Input Current (100% Load)	$T_C < 95^\circ\text{C}$, $V_i = 220\text{ V}$, $V_{\text{PN}} = 390\text{ V}$, $V_{\text{PWM}} = 20\text{ kHz}$	25	A
$I_{i(125\%)}$	Input Current (125% Load)	$T_C < 95^\circ\text{C}$, $V_i = 220\text{ V}$, $V_{\text{PN}} = 390\text{ V}$, $V_{\text{PWM}} = 20\text{ kHz}$, 1 Minute Non-Repetitive	30	A
P_C	Collector Dissipation	$T_C = 25^\circ\text{C}$	169	W
T_J	Operating Junction Temperature		-20 ~ 150	$^\circ\text{C}$

Notes:

1. The maximum junction temperature rating of the power chips integrated within the PFC SPM® product is 150°C ($@T_C \leq 100^\circ\text{C}$). However, to insure safe operation of the PFC SPM product, the average junction temperature should be limited to $T_{\text{J(ave)}} \leq 125^\circ\text{C}$ ($@T_C \leq 100^\circ\text{C}$)

Control Part

Symbol	Item	Condition	Rating	Unit
V_{CC}	Control Supply Voltage	Applied between V_{CC} - COM	20	V
V_{IN}	Input Signal Voltage	Applied between IN - COM	-0.3 ~ $V_{\text{CC}}+0.3$	V
V_{FO}	Fault Output Supply Voltage	Applied between V_{FO} - COM	-0.3 ~ $V_{\text{CC}}+0.3$	V
I_{FO}	Fault Output Current	Sink Current at V_{FO} Pin	5	mA
V_{SC}	Current Sensing Input Voltage	Applied between C_{SC} - COM	-0.3 ~ $V_{\text{CC}}+0.3$	V

Total System

Symbol	Item	Condition	Rating	Unit
T_C	Module Case Operating Temperature		-20 ~ 100	$^\circ\text{C}$
T_{STG}	Storage Temperature		-40 ~ 125	$^\circ\text{C}$
V_{ISO}	Isolation Voltage	60 Hz, Sinusoidal, AC 1 Minute, Connect Pins to Heat Sink Plate	2500	V_{rms}

Thermal Resistance

Symbol	Item	Condition	Min.	Typ.	Max.	Unit
$R_{\theta(j-c)Q}$	Junction to Case Thermal Resistance	IGBT	-	-	0.74	$^\circ\text{C/W}$
$R_{\theta(j-c)F}$		FRD	-	-	1.44	$^\circ\text{C/W}$
$R_{\theta(j-c)R}$		Rectifier (per 1 / 4 module)	-	-	2.07	$^\circ\text{C/W}$

Notes:

2. For the measurement point of case temperature(T_C), please refer to Figure 2.

Electrical Characteristics (T_J = 25°C, Unless Otherwise Specified.)

Converter Part

Symbol	Item	Condition	Min.	Typ.	Max.	Unit
V _{CE(SAT)}	IGBT Saturation Voltage	V _{CC} = 15 V, V _{IN} = 5 V, I _C = 30 A	-	2.0	2.8	V
V _{FF}	FRD Forward Voltage	I _F = 30 A	-	1.8	2.5	V
V _{FR}	Rectifier Forward Voltage	I _F = 30 A	-	1.2	1.5	V
t _{ON}	Switching Times	V _{PN} = 400 V, V _{CC} = 15V, I _C = 30 A V _{IN} = 0 V ↔ 5 V, Inductive Load (Note 3)	-	650	-	ns
t _{C(ON)}			-	400	-	ns
t _{OFF}			-	620	-	ns
t _{C(OFF)}			-	200	-	ns
t _{rr}			-	60	-	ns
I _{rr}			-	3.5	-	A
I _{CES}			Collector - Emitter Leakage Current	V _{CE} = V _{CES}	-	-

Notes:

3. t_{ON} and t_{OFF} include the propagation delay time of the internal drive IC. t_{C(ON)} and t_{C(OFF)} are the switching time of IGBT itself under the given gate driving condition internally. For the detailed information, please see Figure 4.

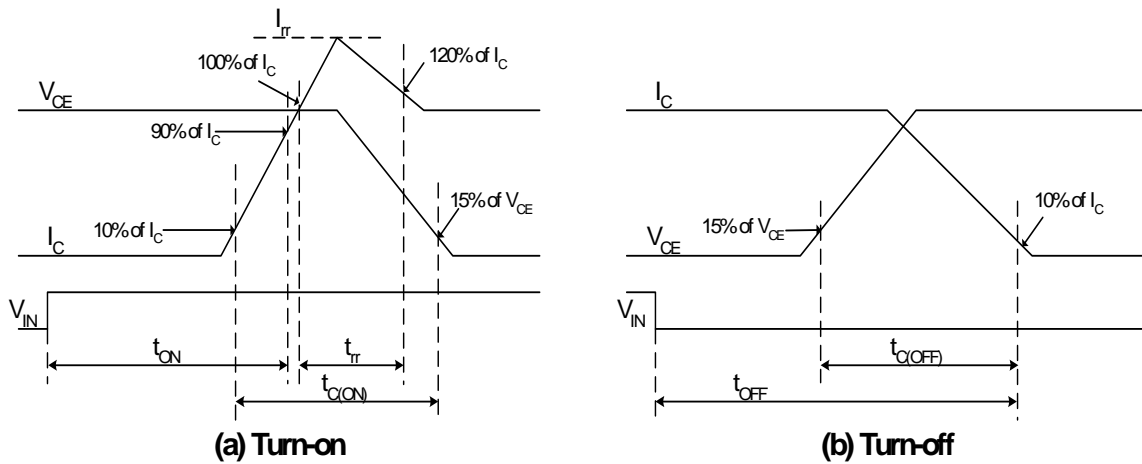

Figure 4. Switching Time Definition

Control Part

Symbol	Item	Condition	Min.	Typ.	Max.	Unit
I _{QCCL}	Quiescent V _{CC} Supply Current	V _{CC} = 15 V, IN = 0 V V _{CC} - COM	-	-	26	mA
V _{FOH}	Fault Output Voltage	V _{SC} = 0 V, V _{FO} Circuit: 4.7 kΩ to 5 V Pull-up	4.5	-	-	V
V _{FOL}		V _{SC} = 1 V, V _{FO} Circuit: 4.7 kΩ to 5 V Pull-up	-	-	0.8	V
V _{SC(ref)}	Over-Current Trip Level	V _{CC} = 15 V	0.45	0.5	0.55	V
UV _{CCD}	Supply Circuit Under-Voltage Protection	Detection Level	10.7	11.9	13.0	V
UV _{CCR}		Reset Level	11.2	12.4	13.2	V
t _{FOD}	Fault-Out Pulse Width	C _{FOD} = 33 nF (Note 3)	1.4	1.8	2.0	ms
V _{IN(ON)}	ON Threshold Voltage	Applied between IN - COM	2.8	-	-	V
V _{IN(OFF)}	OFF Threshold Voltage		-	-	0.8	V
R _{TH}	Resistance of Thermistor	at T _{TH} = 25°C (Note 4, Figure 5)	-	50	-	kΩ
		at T _{TH} = 100°C (Note 4, Figure 5)	-	2.99	-	kΩ

Notes:

3. The fault-out pulse width t_{FOD} depends on the capacitance value of C_{FOD} according to the following approximate equation : C_{FOD} = 18.3 x 10⁻⁶ x t_{FOD}[F]
4. T_{TH} is the temperature of know case temperature(T_C), please make the experiment considering your application.

R-T Graph

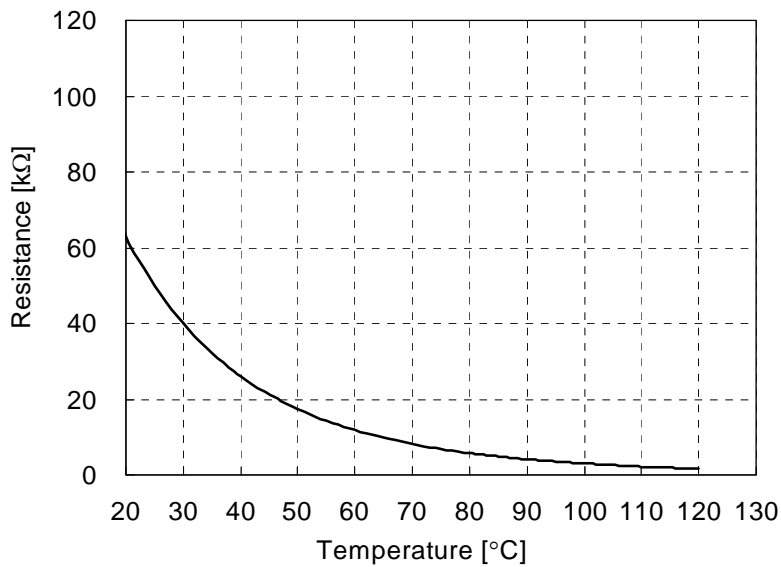

Figure 5. R-T Curve of the Built-In Thermistor

Recommended Operating Condition

Symbol	Item	Condition	Min.	Typ.	Max.	Unit
V_i	Input Supply Voltage	Applied between R - S	187	220	253	V_{rms}
V_{PN}	Output Voltage	Applied between P - N	-	380	400	V
V_{CC}	Control Supply Voltage	Applied between $V_{CC(L)}$ - COM	13.5	15.0	16.5	V
dV_{CC}/dt	Control Supply Variation		-1	-	1	V/ μ s
f_{PWM}	PWM Input Frequency	$T_J \leq 150^\circ\text{C}$	-	20	-	kHz
I_i	Allowable Input Current	$T_C < 90^\circ\text{C}$, $V_i = 220\text{ V}$, $V_{PN} = 380\text{ V}$ $V_{PWM} = 20\text{ kHz}$	-	-	30	A_{peak}

Mechanical Characteristics and Ratings

Item	Condition		Min.	Typ.	Max.	Unit
Mounting Torque	Mounting Screw: M3	Recommended 0.62 N•m	0.51	0.62	0.72	N•m
Device Flatness	See Figure 6		0	-	+120	μm
Weight			-	15.00	-	g

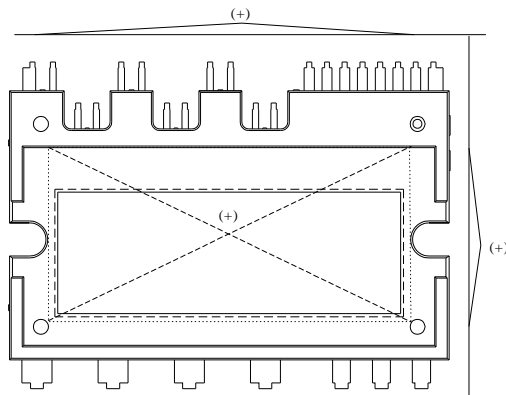
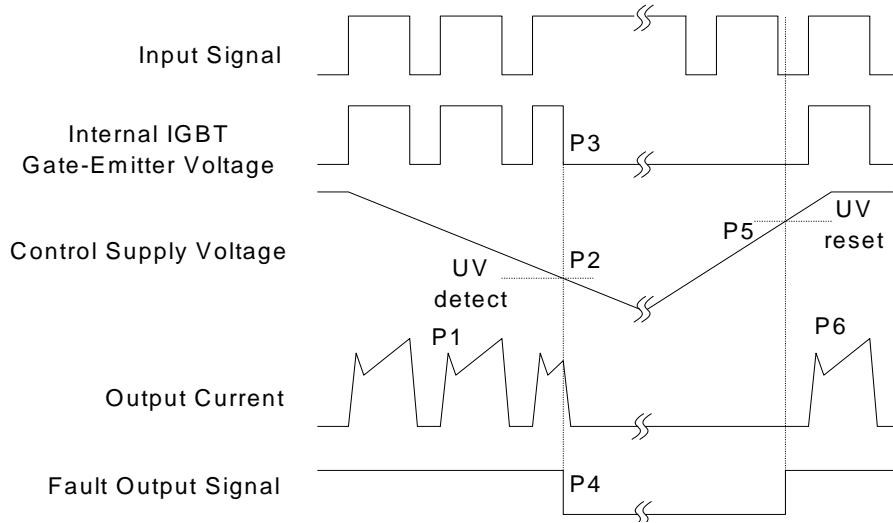

Figure 6. Flatness Measurement Position

Time Charts of Protective Function



- P1 : Normal operation: IGBT ON and conducting current
- P2 : Under-voltage detection
- P3 : IGBT gate interrupt
- P4 : Fault signal generation
- P5 : Under-voltage reset
- P6 : Normal operation: IGBT ON and conducting current

Figure 7. Under-Voltage Protection

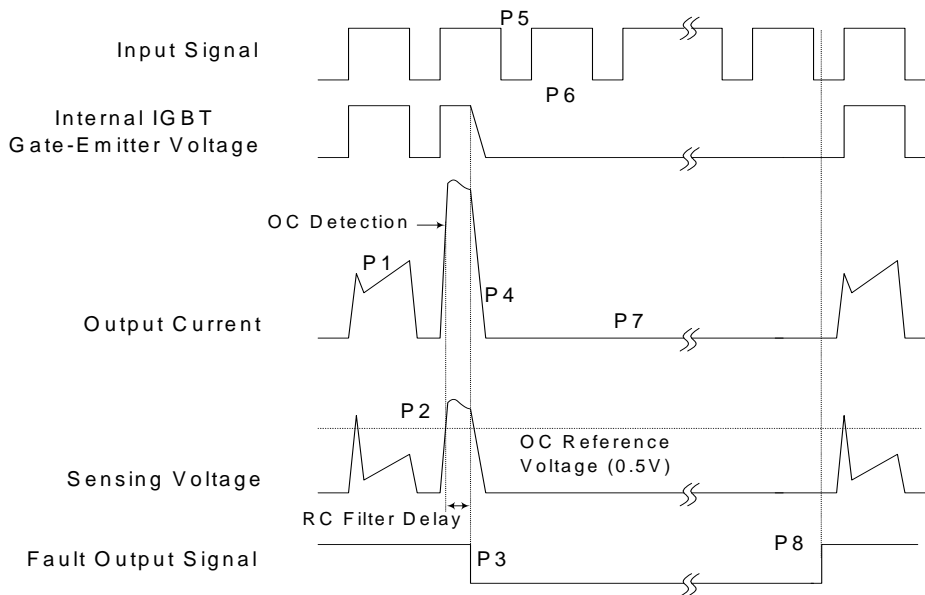

- P1 : Normal operation: IGBT ON and conducting current
- P2 : Over current detection
- P3 : IGBT gate interrupt / fault signal generation
- P4 : IGBT is slowly turned off
- P5 : IGBT OFF signal
- P6 : IGBT ON signal: but IGBT cannot be turned on during the fault output activation
- P7 : IGBT OFF state
- P8 : Fault output reset and normal operation start

Figure 8. Over-Current Protection

Detailed Package Outline Drawings

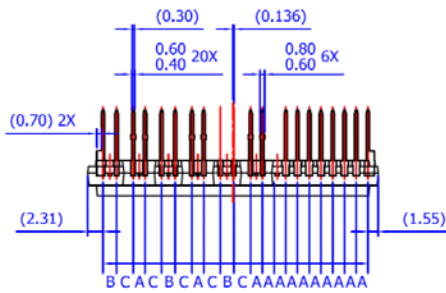

LEAD PITCH (TOLERANCE : ±0.30)
 A : 1.778
 B : 2.050
 C : 2.531

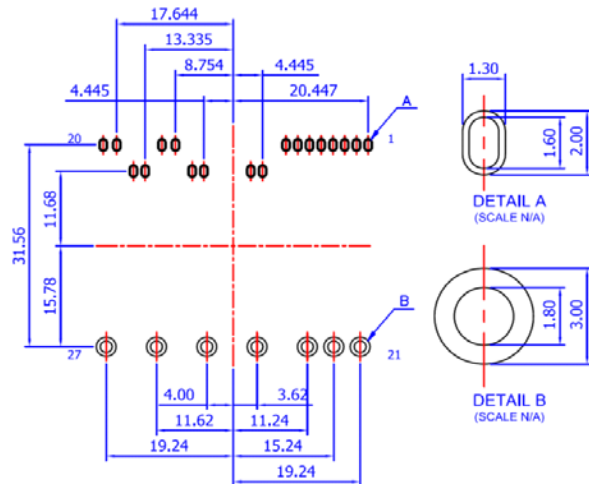
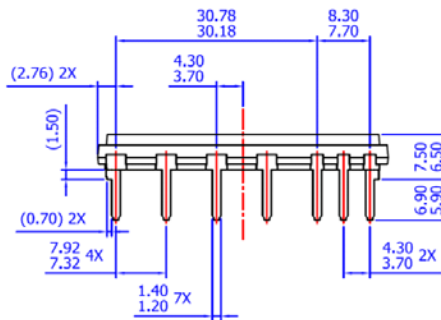
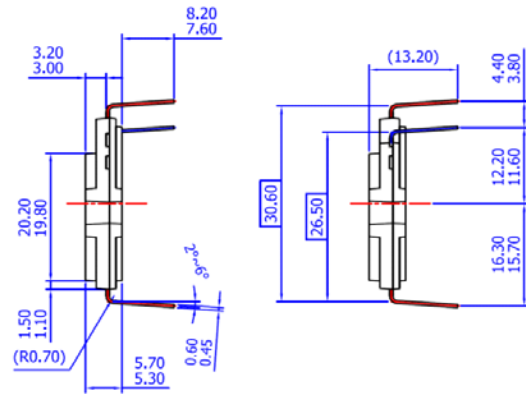
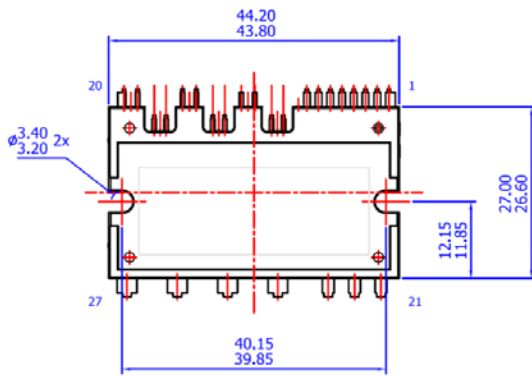

LAND PATTERN RECOMMENDATIONS

- NOTES: UNLESS OTHERWISE SPECIFIED
 A) THIS PACKAGE DOES NOT COMPLY TO ANY CURRENT PACKAGING STANDARD
 B) ALL DIMENSIONS ARE IN MILLIMETERS
 C) DIMENSIONS ARE EXCLUSIVE OF BURRS, MOLD FLASH, AND TIE BAR EXTRUSIONS
 D) () IS REFERENCE
 E) [] IS ASS'Y QUALITY
 F) DRAWING FILENAME: MOD27BEREV2.0
 G) FAIRCHILD SEMICONDUCTOR

Package drawings are provided as a service to customers considering Fairchild components. Drawings may change in any manner without notice. Please note the revision and/or data on the drawing and contact a FairchildSemiconductor representative to verify or obtain the most recent revision. Package specifications do not expand the terms of Fairchild's worldwide therm and conditions, specifically the the warranty therein, which covers Fairchild products.





Always visit Fairchild Semiconductor's online packaging area for the most recent package drawings:

<http://www.fairchildsemi.com/dwg/MO/MOD27BE.pdf>

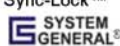

TRADEMARKS

The following includes registered and unregistered trademarks and service marks, owned by Fairchild Semiconductor and/or its global subsidiaries, and is not intended to be an exhaustive list of all such trademarks.

AccuPower™	F-PFS™		Sync-Lock™
AX-CAP®*	FRFET®	PowerTrench®	
BitSiC™	Global Power Resource™	PowerXS™	TinyBoost®
Build it Now™	GreenBridge™	Programmable Active Droop™	TinyBuck®
CorePLUS™	Green FPS™	QFET®	TinyCalc™
CorePOWER™	Green FPS™ e-Series™	QS™	TinyLogic®
CROSSVOLT™	Gmax™	Quiet Series™	TINYOPTO™
CTL™	GTO™	RapidConfigure™	TinyPower™
Current Transfer Logic™	IntelliMAX™		TinyPWM™
DEUXPEED®	ISOPLANAR™	Saving our world, 1mW/W/kW at a time™	TinyWire™
Dual Cool™	Making Small Speakers Sound Louder and Better™	SignalWise™	TranSiC™
EcoSPARK®	MegaBuck™	SmartMax™	TriFault Detect™
EfficientMax™	MICROCOUPLER™	SMART START™	TRUECURRENT®*
ESBC™	MicroFET™	Solutions for Your Success™	µSerDes™
	MicroPak™	SPM®	
Fairchild®	MicroPak2™	STEALTH™	UHC®
Fairchild Semiconductor®	MillerDrive™	SuperFET®	Ultra FRFET™
FACT Quiet Series™	MotionMax™	SuperSOT™-3	UniFET™
FACT®	mWSaver®	SuperSOT™-6	VCX™
FAST®	OptoHiT™	SuperSOT™-8	VisualMax™
FastvCore™	OPTOLOGIC®	SupreMOS®	VoltagePlus™
FETBench™	OPTOPLANAR®	SyncFET™	XS™
FPS™			

* Trademarks of System General Corporation, used under license by Fairchild Semiconductor.

DISCLAIMER

FAIRCHILD SEMICONDUCTOR RESERVES THE RIGHT TO MAKE CHANGES WITHOUT FURTHER NOTICE TO ANY PRODUCTS HEREIN TO IMPROVE RELIABILITY, FUNCTION, OR DESIGN. FAIRCHILD DOES NOT ASSUME ANY LIABILITY ARISING OUT OF THE APPLICATION OR USE OF ANY PRODUCT OR CIRCUIT DESCRIBED HEREIN; NEITHER DOES IT CONVEY ANY LICENSE UNDER ITS PATENT RIGHTS, NOR THE RIGHTS OF OTHERS. THESE SPECIFICATIONS DO NOT EXPAND THE TERMS OF FAIRCHILD'S WORLDWIDE TERMS AND CONDITIONS, SPECIFICALLY THE WARRANTY THEREIN, WHICH COVERS THESE PRODUCTS.

LIFE SUPPORT POLICY

FAIRCHILD'S PRODUCTS ARE NOT AUTHORIZED FOR USE AS CRITICAL COMPONENTS IN LIFE SUPPORT DEVICES OR SYSTEMS WITHOUT THE EXPRESS WRITTEN APPROVAL OF FAIRCHILD SEMICONDUCTOR CORPORATION.

As used herein:

1. Life support devices or systems are devices or systems which, (a) are intended for surgical implant into the body or (b) support or sustain life, and (c) whose failure to perform when properly used in accordance with instructions for use provided in the labeling, can be reasonably expected to result in a significant injury of the user.
2. A critical component in any component of a life support, device, or system whose failure to perform can be reasonably expected to cause the failure of the life support device or system, or to affect its safety or effectiveness.

ANTI-COUNTERFEITING POLICY

Fairchild Semiconductor Corporation's Anti-Counterfeiting Policy. Fairchild's Anti-Counterfeiting Policy is also stated on our external website, www.fairchildsemi.com, under Sales Support.

Counterfeiting of semiconductor parts is a growing problem in the industry. All manufacturers of semiconductor products are experiencing counterfeiting of their parts. Customers who inadvertently purchase counterfeit parts experience many problems such as loss of brand reputation, substandard performance, failed applications, and increased cost of production and manufacturing delays. Fairchild is taking strong measures to protect ourselves and our customers from the proliferation of counterfeit parts. Fairchild strongly encourages customers to purchase Fairchild parts either directly from Fairchild or from Authorized Fairchild Distributors who are listed by country on our web page cited above. Products customers buy either from Fairchild directly or from Authorized Fairchild Distributors are genuine parts, have full traceability, meet Fairchild's quality standards for handling and storage and provide access to Fairchild's full range of up-to-date technical and product information. Fairchild and our Authorized Distributors will stand behind all warranties and will appropriately address any warranty issues that may arise. Fairchild will not provide any warranty coverage or other assistance for parts bought from Unauthorized Sources. Fairchild is committed to combat this global problem and encourage our customers to do their part in stopping this practice by buying direct or from authorized distributors.

PRODUCT STATUS DEFINITIONS

Definition of Terms

Datasheet Identification	Product Status	Definition
Advance Information	Formative / In Design	Datasheet contains the design specifications for product development. Specifications may change in any manner without notice.
Preliminary	First Production	Datasheet contains preliminary data; supplementary data will be published at a later date. Fairchild Semiconductor reserves the right to make changes at any time without notice to improve design.
No Identification Needed	Full Production	Datasheet contains final specifications. Fairchild Semiconductor reserves the right to make changes at any time without notice to improve the design.
Obsolete	Not In Production	Datasheet contains specifications on a product that is discontinued by Fairchild Semiconductor. The datasheet is for reference information only.

Rev. 166