

DRAWING FOR REFERENCE: This is subject to change without notice
08/11/2012

1		2			3			4		
COUNT	DESCRIPTION OF REVISIONS	BY	CHKD	DATE	COUNT	DESCRIPTION OF REVISIONS	BY	CHKD	DATE	
△					△					
△					△					
△					△					

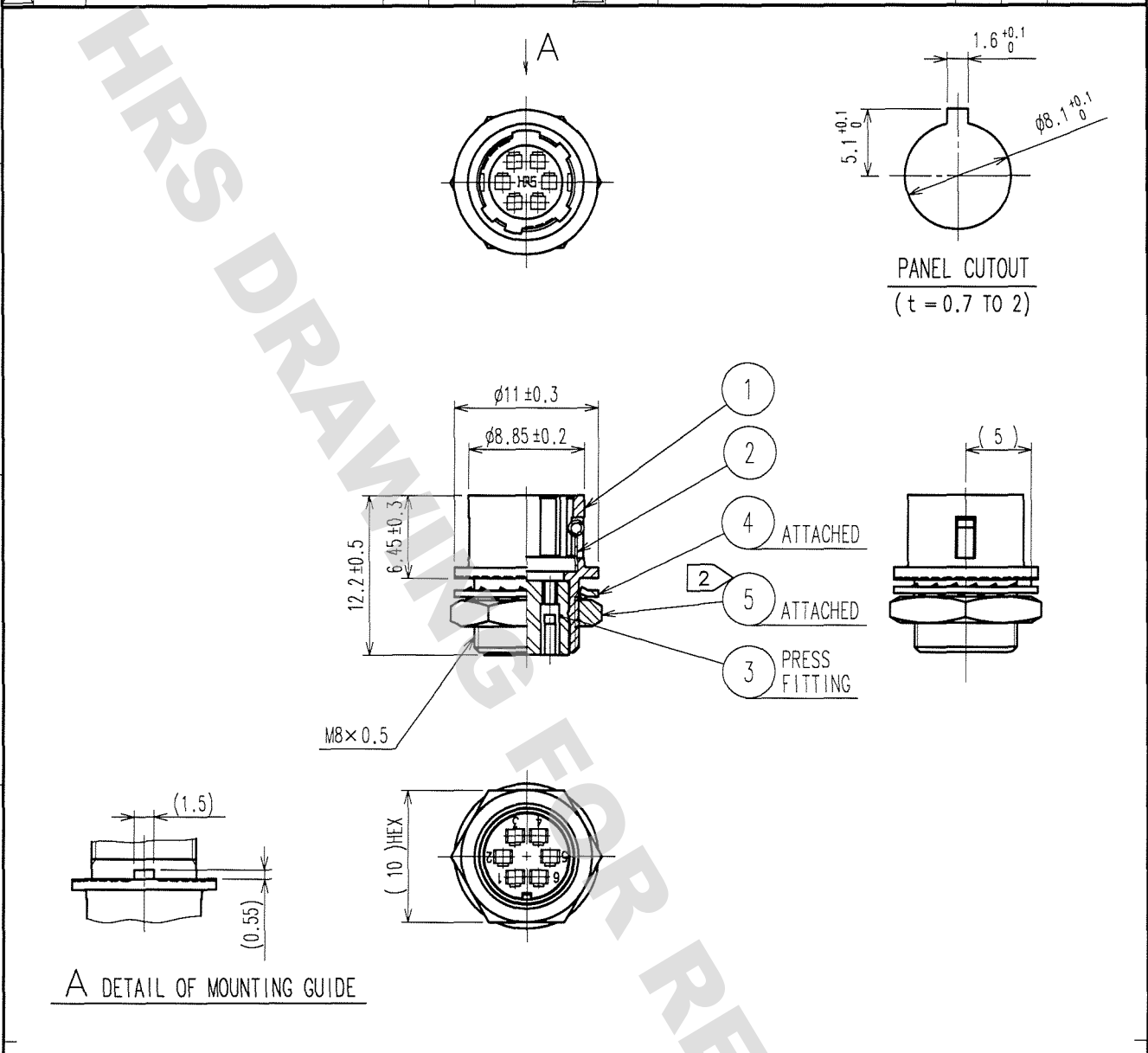

A DETAIL OF MOUNTING GUIDE

NOTES 1 APPLICABLE CRIMP CONTACT:HR10-PC-212(CL110-0514-3)
 APPLICABLE WIRE:AWG#26 TO #30(COVERED WIRE MAX,OUTSIDE DIA.φ 1)
 APPLICABLE CONTACT REMOVAL TOOL(EXTRACTION TOOL):RP6-SC-TP(CL150-0039-0)
 ② THE RECOMMENDED CLAMP TORQUE OF REF. NO. ⑤ TO BE 1.5 N·m.
 LOCTITE 242, HENKEL JAPAN OR EQUIVALENT IS RECOMMENDED TO PREVENT REF. NO. ⑤ FROM LOOSENING.

NO.	MATERIAL	FINISH, REMARKS	NO.	MATERIAL	FINISH, REMARKS
3	POLYBUTYLENE TEREPHTHALATE	(BLACK) UL94V-0			
2	STAINLESS STEEL		5	BRASS	NICKEL PLATING
1	ZINC ALLOY	MATTE FINISH NICKEL PLATED	4	PHOSPHOR BRONZE	NICKEL PLATING

CODE NO. (OLD)	CL	DRAWN	DESIGNED	CHECKED	APPROVED	RELEASED
		<i>M. Sato</i>	<i>T. Hosoi</i>	<i>E. Kunita</i>	<i>M. Sato</i>	
		07.04.11	07.04.11	07.04.11	07.04.11	

	DRAWING NO.	PART NO.		
	EDC4-042729-73	HR10G-7R-6PC(73)		
SCALE	CODE NO.			
2 : 1	CL110-1706-0-73			
UNITS	HIROSE ELECTRIC CO.,LTD.			
mm	<table border="1"> <tr> <td>1</td> <td>1</td> </tr> </table>		1	1
1	1			

TO
R