

OSRAM PLPM7 455QA_LL

Datasheet

Published by **ams-OSRAM AG**

Tobelbader Strasse 30, 8141 Premstaetten, Austria

Phone +43 3136 500-0

ams-osram.com

© All rights reserved



PLPM7 455QA_LL

Blue emitting high power multi-die Edge Emitting Laser including beam collimation for all kind of highest power application requiring phosphor conversion or direct emitting blue laser light emission

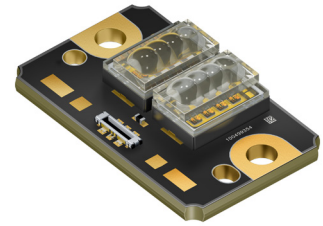

Applications

- Entertainment
- Outdoor & Industrial Lighting
- Projection & Display

Features

- Package: Hermetic Multi Laser Die Top Emitter Package on MCB
- Chip Technology: Multimode EEL
- Typical emission wavelength: 455 nm
- Typical optical power: 42W
- Typ. wall plug efficiency of 45%
- Collimated beam output
- NTC & Connector on board

Ordering Information

Type	Peak output power typ. P_{opt}	Ordering Code
PLPM7 455QA_LL	42 W	Q65115A1126

Maximum Ratings

Parameter	Symbol		Values
Operating temperature ¹⁾	T_{op}	min.	0 °C
		max.	70 °C
Storage temperature	T_{stg}	min.	-40 °C
		max.	85 °C
Junction temperature	T_j	max.	135 °C
Forward current	I_F	max.	3.5 A
Reverse current	I_R	max.	85 mA
Reverse voltage for Zener diode at condition 5mA/25°C and no irradiation	V_R	max.	15.5 V

Operation outside these conditions may damage the device. Operation at the maximum ratings influences lifetime.

Characteristics

$I_F = 3.0 \text{ A}$; $T_{op} = 25^\circ\text{C}$

Parameter	Symbol		Values
Dominant wavelength ²⁾	λ_{dom}	min.	449 nm
		typ.	455 nm
		max.	461 nm
Optical output power ³⁾	P_{opt}	min.	38 W
		typ.	42 W
Beam divergence ($1/e^2$) parallel to pn-junction	$\Theta_{ }$	min.	0 °
		typ.	0.8 °
		max.	1.6 °
Beam divergence ($1/e^2$) perpendicular to pn-junction	Θ_{\perp}	min.	-1.5 °
		typ.	0 °
		max.	1.5 °
Beam pointing tilt angle ⁴⁾ $\Delta\theta = \sqrt{(\Delta\theta_{ })^2 + (\Delta\theta_{\perp})^2}$	$\Delta\theta$	max.	1.2 °
Total conversion efficiency	η_{tot}	min.	41 %
		typ.	45 %
Slope efficiency	η	typ.	16.2 W / A
Threshold current	I_{th}	min.	0.24 A
		max.	0.44 A
Forward voltage ⁵⁾	V_F	typ.	31 V
		max.	36 V
Forward voltage ⁵⁾ for Zener diode at condition 20mA/25°C and no irradiation	V_F	min.	0.75 V
		max.	1.20 V
TE polarization (Preliminary value)	P_{TE}	typ.	70:1
Thermal resistance junction board (Board = NTC)	$R_{thJB \text{ real}}$	typ.	0.9 K / W

Relative Spectral Emission ^{6), 7)}

$$P_{opt} = f(\lambda); I_F = 3.0 \text{ A}; T_{op} = 25 \text{ }^\circ\text{C}$$

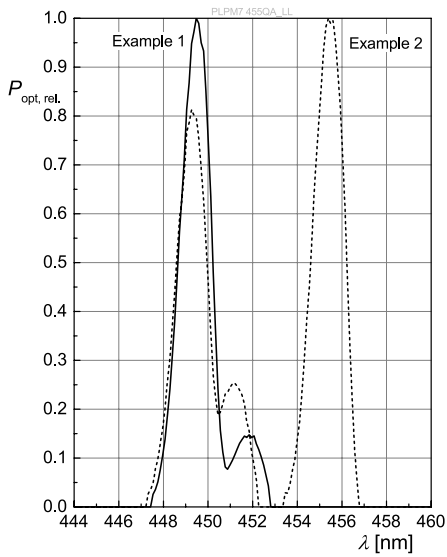

Optical Output Power ^{6), 7)}

$$P_{opt} = f(I_F)$$

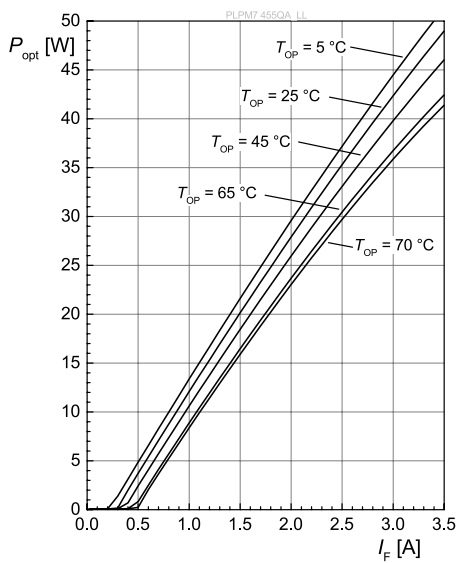

Operating Voltage ^{6), 7)}

$$V_F = f(I_F)$$

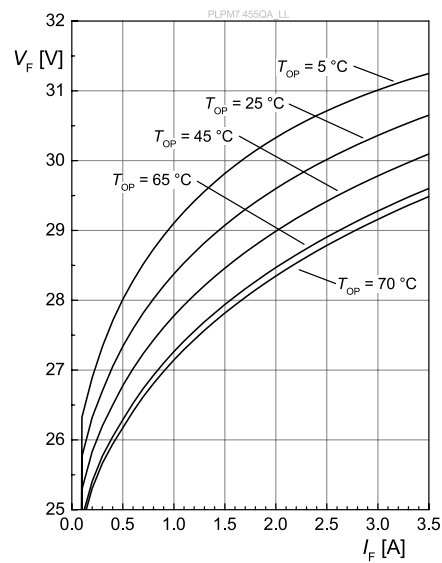

Dominant Wavelength ^{6), 7)}

$$\lambda_{dom} = f(I_F)$$

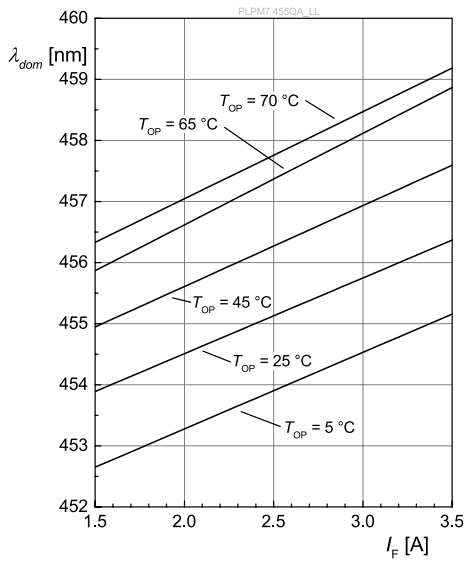



Threshold Current ⁶⁾

$$I_{th} = f(T_{op})$$

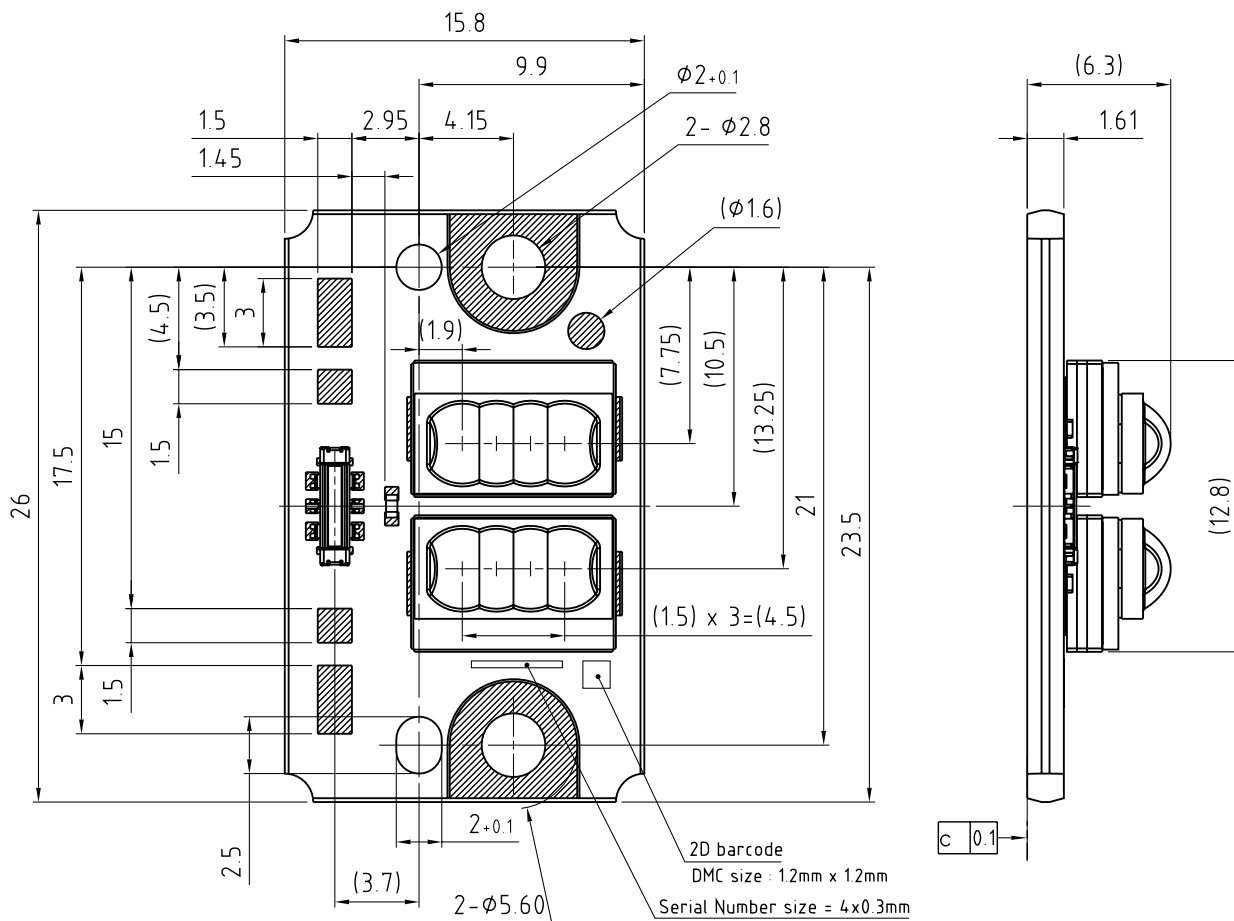

Dimensional Drawing ⁸⁾



 lead finish Au

Note :
Tolerance is based on ISO 2768-1 m

Range	0.5 to 3	above 3 to 6	above 6 to 30
Tolerance	±0.1	±0.1	±0.2

C67062-A0498-A1 -04

Electrical Internal Circuit

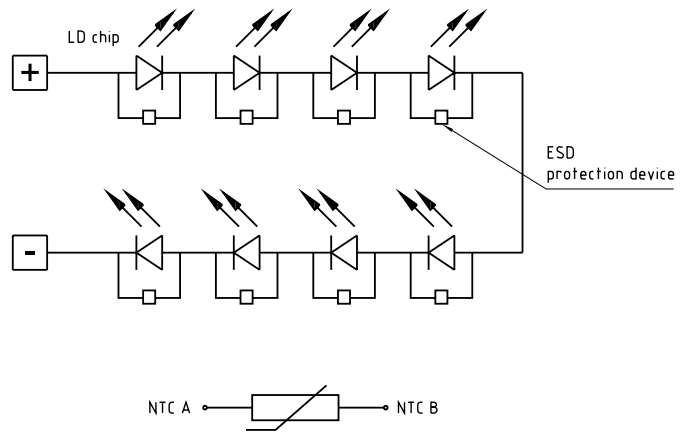
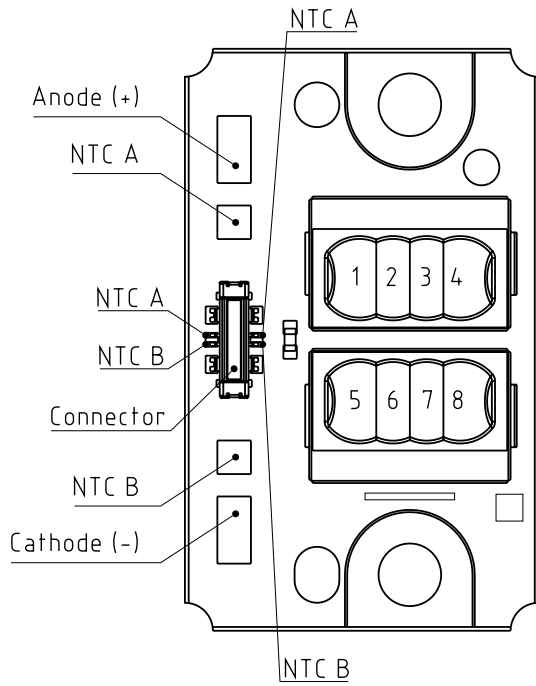

Parts	Supplier	Part No.
NTC	TDK	B57230V2103F260
Connector	Japan Aviation Electronics Industry, Ltd	WP10-P004 VA10-R15000

Taping ⁸⁾

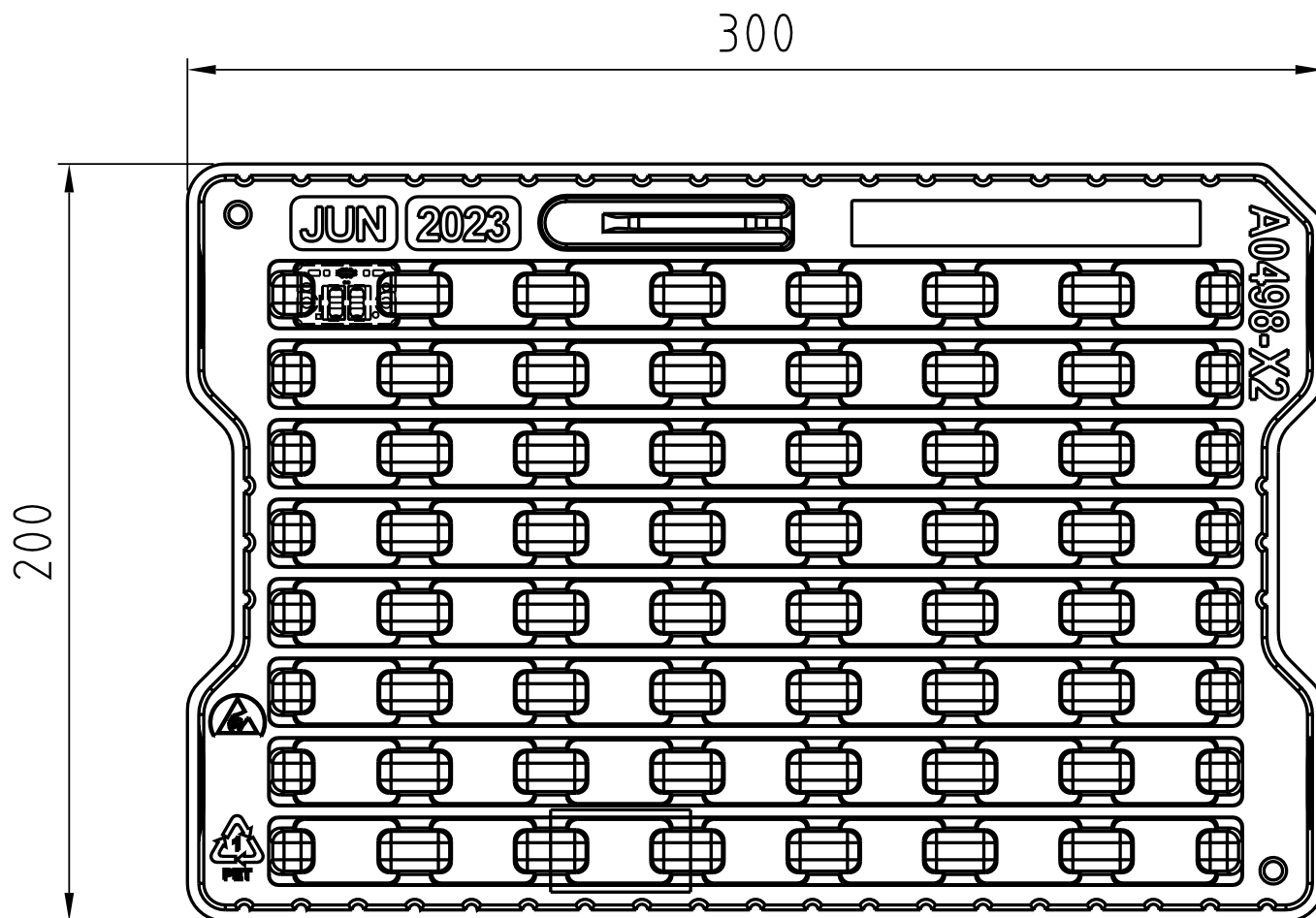

2x completely filled trays
1x empty tray on top

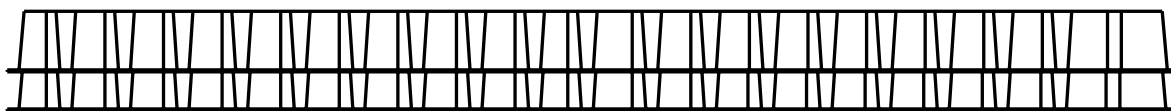

Barcode-Product-Label (BPL)

OSRAM LX XXXX BIN1: XX-XX-X-XXX-X

RoHS Compliant

(6P) BATCH NO: 1234567890

(1T) LOT NO: 1234567890 (9D) D/C: 1234

(X) PROD NO: 123456789 (Q) QTY: 9999 (G) GROUP: XX-XX-X-X

ML Temp ST
X XXX °C X

Pack: RXX
DEMY XXX
X_X123_1234.1234 X

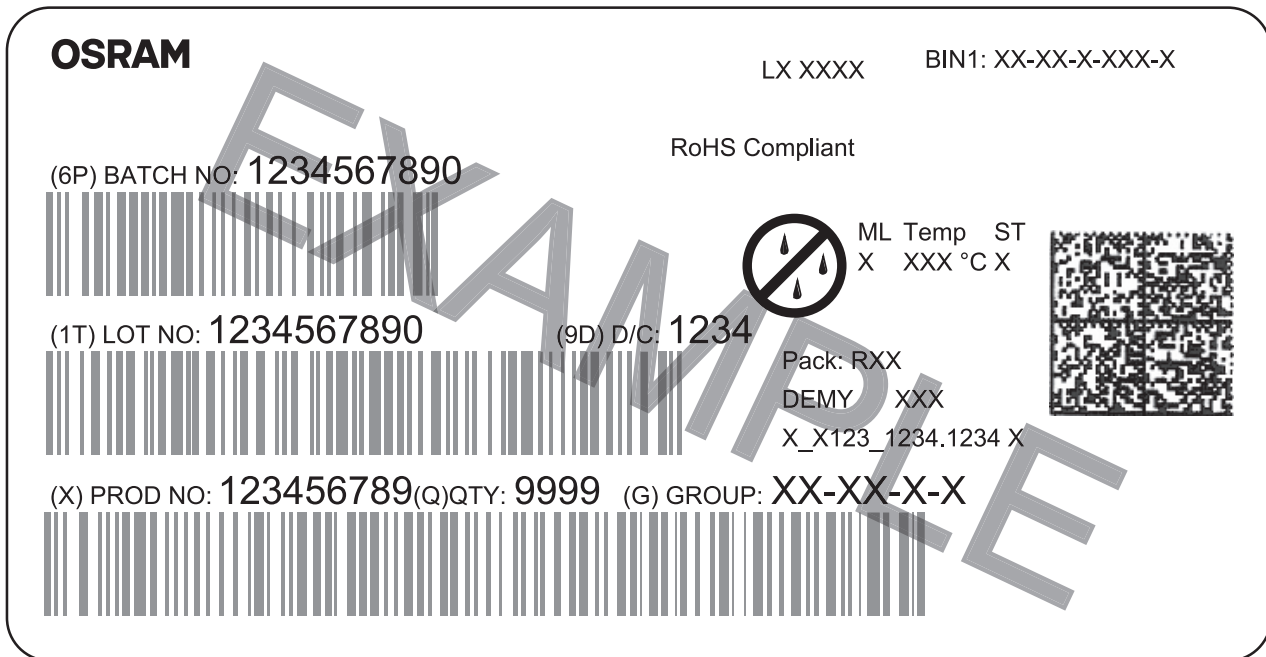

The diagram shows a rectangular label with rounded corners. It contains the OSRAM logo in the top left. To its right are the fields 'LX XXXX' and 'BIN1: XX-XX-X-XXX-X'. Below the logo is a large barcode. To the right of this barcode is the text 'RoHS Compliant' and a circular icon with a diagonal line through it and three raindrops. Further right is the text 'ML Temp ST' and 'X XXX °C X'. Below the first barcode is another barcode, with the text '(1T) LOT NO: 1234567890' and '(9D) D/C: 1234' to its right. To the right of this second barcode is a square QR code. Below the second barcode is a third barcode, with the text '(X) PROD NO: 123456789 (Q) QTY: 9999 (G) GROUP: XX-XX-X-X' to its right. To the right of this third barcode is the text 'Pack: RXX', 'DEMY XXX', and 'X_X123_1234.1234 X'. A large, light gray watermark 'EXAMPLE' is overlaid diagonally across the entire label area.

OHA04563

Dry Packing Process and Materials

Box

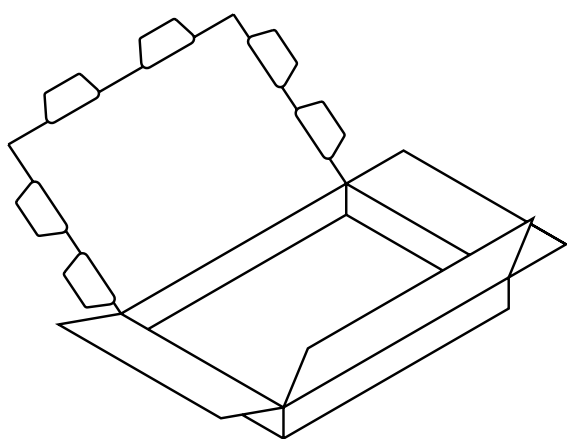

Barcode label

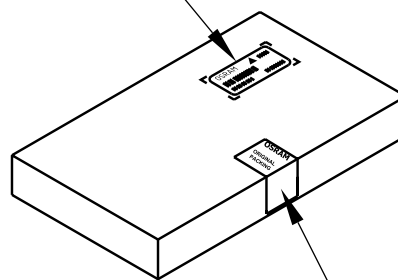

Original packing label

Notes

Subcomponents of this device contain, in addition to other substances, metal filled materials including silver. Metal filled materials can be affected by environments that contain traces of aggressive substances. Therefore, we recommend that customers minimize device exposure to aggressive substances during storage, production, and use. Devices that showed visible discoloration when tested using the described tests above did show no performance deviations within failure limits during the stated test duration. Respective failure limits are described in the IEC 60810.

For further application related information please visit <https://ams-osram.com/support/application-notes>

Depending on the mode of operation, these devices emit highly concentrated visible light which can be Hazardous to the human eye. Products which incorporate these devices have to follow the safety precautions found in IEC 60825-1 "Safety of laser products".



IEC 60825-1: 2014

Max radiation power: 50 W (449 - 461 nm)

Disclaimer

Attention please!

The information describes the type of component and shall not be considered as assured characteristics. Terms of delivery and rights to change design reserved. Due to technical requirements components may contain dangerous substances.

For information on the types in question please contact our Sales Organization.

If printed or downloaded, please find the latest version on our website.

Packing

Please use the recycling operators known to you. We can also help you – get in touch with your nearest sales office. By agreement we will take packing material back, if it is sorted. You must bear the costs of transport. For packing material that is returned to us unsorted or which we are not obliged to accept, we shall have to invoice you for any costs incurred.

Product and functional safety devices/applications or medical devices/applications

Our components are not developed, constructed or tested for the application as safety relevant component or for the application in medical devices.

Our products are not qualified at module and system level for such application.

In case buyer – or customer supplied by buyer – considers using our components in product safety devices/ applications or medical devices/applications, buyer and/or customer has to inform our local sales partner immediately and we and buyer and /or customer will analyze and coordinate the customer-specific request between us and buyer and/or customer.

Glossary

- 1) **Operating temperature:** The operating temperature is defined as the temperature measured at NTC on MCPCB.
- 2) **Wavelength:** The wavelengths are measured with a tolerance of ± 1 nm.
- 3) **Brightness:** The brightness values are measured with a tolerance of $\pm 11\%$.
- 4) **Beam pointing tilt angle accuracy:** The values may contain measurement deviations.
- 5) **Forward Voltage:** The forward voltages are measured with a tolerance of ± 0.1 V.
- 6) **Typical Values:** Due to the special conditions of the manufacturing processes of semiconductor devices, the typical data or calculated correlations of technical parameters can only reflect statistical figures. These do not necessarily correspond to the actual parameters of each single product, which could differ from the typical data and calculated correlations or the typical characteristic line. If requested, e.g. because of technical improvements, these typ. data will be changed without any further notice.
- 7) **Testing temperature:** TA = 25°C (unless otherwise specified)
- 8) **Tolerance of Measure:** Unless otherwise noted in drawing, tolerances are specified with ± 0.1 and dimensions are specified in mm.

Revision History

Version	Date	Change
1.0	2025-08-19	Initial Version



EU RoHS and China RoHS compliant product

此产品符合欧盟 RoHS 指令的要求；
按照中国的相关法规和标准，
不含有毒有害物质或元素。

Published by ams-OSRAM AG

Tobelbader Strasse 30, 8141 Premstaetten, Austria

Phone +43 3136 500-0

ams-osram.com

© All rights reserved

am 

OSRAM