

Aluminum Electrolytic Capacitors Power Ripple Miniature Snap-In

**RoHS
COMPLIANT**

FEATURES

- Up to 500 V
- Useful life: 5000 h at 85 °C
- > 10 years 24/7 application life up to 50 °C
- 10 % to 20 % higher ripple current rating than 093 PMG-SI
- Keyed polarity version available
- Material categorization: for definitions of compliance please see www.vishay.com/doc?99912

APPLICATIONS

- Mains connected medical equipment, test and measurement instruments, and industrial control units
- Motor drives for internal transport, escalators, or automatic gates
- Welding inverters for consumer use
- Audio amplifiers

MARKING

The capacitors are marked (where possible) with the following information:

- Rated capacitance (in μF)
- Tolerance on rated capacitance, code letter in accordance with IEC 60062 (M for $\pm 20\%$)
- Rated voltage (in V)
- Date code (YYMM or in 2 digits according to IEC 60062)
- Name of manufacturer
- Code for factory of origin
- “-” sign to identify the negative terminal, visible from the top and side of the capacitor
- Code number, last 8 digits 257 xxxxx
- Climatic category in accordance with IEC 60068

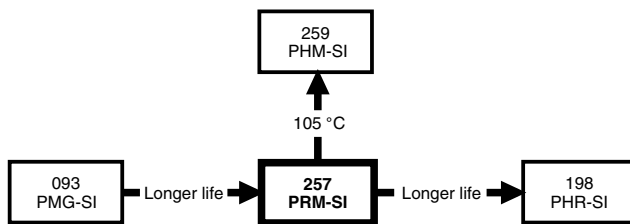

Fig. 1

QUICK REFERENCE DATA	
DESCRIPTION	VALUE
Nominal case sizes (Ø D x L in mm)	22 x 25 to 35 x 60
Rated capacitance range, C_R	56 μF to 3300 μF
Tolerance on C_R	$\pm 20\%$
Rated voltage range, U_R	200 V to 450 V 500 V
Category temperature range	-40 °C to +85 °C -25 °C to +85 °C
Endurance test at 85 °C	3000 h
Useful life at 85 °C	5000 h
Shelf life at 0 V, 85 °C	1000 h
Based on sectional specification	IEC 60384-4 / EN 130300
Climatic category IEC 60038	40 / 85 / 56 25 / 85 / 56

SELECTION CHART FOR C_R , U_R , AND RELEVANT NOMINAL CASE SIZES (Ø D x L in mm)					
C_R (μF)	U_R (V)				
	200	250	400	450	500
56	-	-	-	-	22 x 25
68	-	-	-	22 x 25	-
82	-	-	22 x 25	-	22 x 30
	-	-	-	-	25 x 25
100	-	-	-	22 x 30	22 x 35
	-	-	-	25 x 25	25 x 30



SELECTION CHART FOR C _R , U _R , AND RELEVANT NOMINAL CASE SIZES (∅ D x L in mm)					
C _R (μF)	U _R (V)				
	200	250	400	450	500
120	-	-	22 x 30	22 x 35	22 x 40
	-	-	25 x 25	25 x 30	30 x 25
150	-	-	22 x 35	22 x 40	25 x 35
	-	-	-	30 x 25	-
180	-	-	22 x 40	25 x 35	25 x 40
	-	-	25 x 30	-	30 x 30
	-	-	30 x 25	-	35 x 25
220	-	22 x 25	22 x 45	25 x 45	25 x 50
	-	-	25 x 35	30 x 30	30 x 35
	-	-	-	35 x 25	35 x 30
270	-	25 x 25	25 x 40	25 x 50	30 x 40
	-	-	30 x 30	30 x 35	-
	-	-	35 x 25	35 x 30	-
330	22 x 25	22 x 30	25 x 45	30 x 40	30 x 45
	-	-	30 x 35	-	35 x 35
390	22 x 30	22 x 35	30 x 40	30 x 45	30 x 50
	25 x 25	25 x 30	35 x 30	35 x 35	35 x 40
470	22 x 35	22 x 40	30 x 45	35 x 40	35 x 45
	25 x 30	30 x 25	35 x 35	-	-
	30 x 25	-	-	-	-
560	22 x 35	22 x 45	30 x 50	35 x 45	35 x 50
	25 x 30	25 x 35	35 x 40	-	-
	30 x 25	30 x 30	-	-	-
680	22 x 40	25 x 45	35 x 45	35 x 55	35 x 60
	25 x 35	30 x 35	-	-	-
	-	35 x 25	-	-	-
820	22 x 45	25 x 50	35 x 50	-	-
	25 x 40	35 x 30	-	-	-
	30 x 30	-	-	-	-
	35 x 25	-	-	-	-
1000	25 x 45	30 x 40	35 x 60	-	-
	30 x 35	-	-	-	-
1200	25 x 50	30 x 45	-	-	-
	30 x 35	35 x 35	-	-	-
	35 x 30	-	-	-	-
1500	30 x 45	35 x 45	-	-	-
	35 x 35	-	-	-	-
1800	30 x 50	35 x 50	-	-	-
	35 x 40	-	-	-	-
2200	35 x 45	35 x 55	-	-	-
2700	35 x 50	-	-	-	-
3300	35 x 60	-	-	-	-

DIMENSIONS in millimeters **AND AVAILABLE FORMS**

TWO TERMINAL SNAP-IN

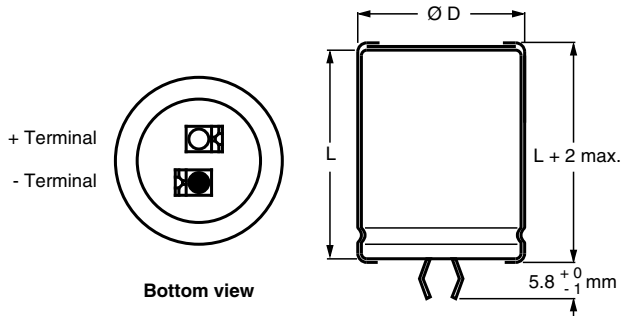

The minus terminal can be marked with a black dot or with an imprinted “-” sign.

Fig. 2 - Two terminal snap-in

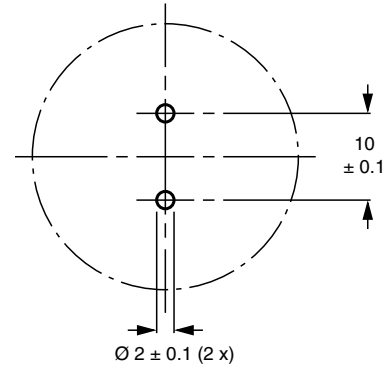
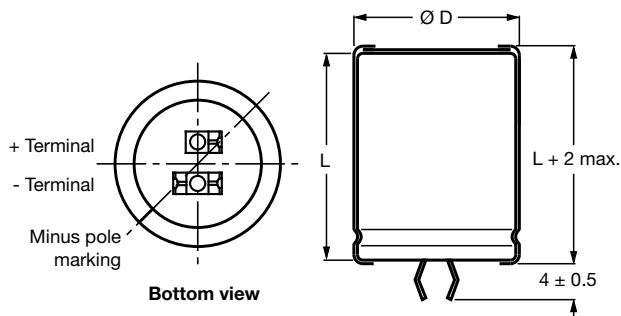

Fig. 3 - Mounting hole diagram

THREE TERMINAL SNAP-IN



The negative terminal has **TWO** pins which are **BOTH** electrically connected.

Fig. 4 - Three terminal snap-in

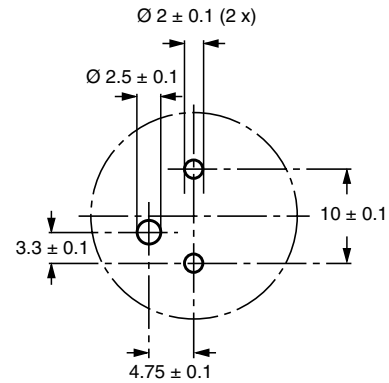

The 10 mm spacing of the 2 pin snap-in is used as the base layout and a third hole is added. The third hole is closer to the negative primary hole so that polarization is always maintained, together with added mechanical stability.

Fig. 5 - Mounting hole diagram



Table 1

DIMENSIONS in millimeters, MASS AND PACKAGING QUANTITIES					
NOMINAL CASE SIZE Ø D x L	Ø D_{max.}	L_{max.}	MASS (g)	PACKAGING QUANTITIES (units per box)	CARDBOARD BOX DIMENSIONS L x W x H
22 x 25	23	27	≈ 12	100	260 x 250 x 39
22 x 30	23	32	≈ 16	100	260 x 250 x 44
22 x 35	23	37	≈ 20	100	260 x 250 x 49
22 x 40	23	42	≈ 23	100	260 x 250 x 54
22 x 45	23	47	≈ 26	100	260 x 250 x 59
25 x 25	26	27	≈ 20	100	290 x 280 x 39
25 x 30	26	32	≈ 22	100	290 x 280 x 44
25 x 35	26	37	≈ 24	100	290 x 280 x 49
25 x 40	26	42	≈ 27	100	290 x 280 x 54
25 x 45	26	47	≈ 32	100	290 x 280 x 59
25 x 50	26	52	≈ 38	100	290 x 280 x 64
30 x 25	31	27	≈ 25	100	340 x 330 x 39
30 x 30	31	32	≈ 30	100	340 x 330 x 44
30 x 35	31	37	≈ 35	100	340 x 330 x 49
30 x 40	31	42	≈ 40	100	340 x 330 x 54
30 x 45	31	47	≈ 45	100	340 x 330 x 59
30 x 50	31	52	≈ 50	100	340 x 330 x 64
35 x 25	36	27	≈ 33	50	390 x 198 x 39
35 x 30	36	32	≈ 40	50	390 x 198 x 44
35 x 35	36	37	≈ 48	50	390 x 198 x 49
35 x 40	36	42	≈ 55	50	390 x 198 x 54
35 x 45	36	47	≈ 63	50	390 x 198 x 59
35 x 50	36	52	≈ 72	50	390 x 198 x 64
35 x 55	36	57	≈ 80	50	390 x 198 x 69
35 x 60	36	62	≈ 82	50	390 x 198 x 74

ELECTRICAL DATA	
SYMBOL	DESCRIPTION
C _R	Rated capacitance at 100 Hz
I _R	Rated RMS ripple current at 100 Hz, 85 °C
I _{L5}	Max. leakage current after 5 min at U _R
ESR	Typ. / max. equivalent series resistance at 100 Hz
Z	Typ. / max. impedance at 10 kHz

Note

- Unless otherwise specified, all electrical values in Table 2 apply at T_{amb} = 20 °C, P = 86 kPa to 106 kPa, RH = 45 % to 75 %

ORDERING EXAMPLE

Electrolytic capacitor 257 series

1000 µF / 200 V; ± 20 %

Nominal case size: Ø 30 x 35 mm

2-terminal snap-in:

Ordering code: MAL2 257 32102 E3

3-terminal snap-in:

Ordering code: MAL2 257 82102 E3



Table 2

ELECTRICAL DATA AND ORDERING INFORMATION										
U _R (V)	C _R 100 Hz (μF)	NOMINAL CASE SIZE Ø D x L (mm)	I _R 100 Hz (A)	I _{L5} (mA)	TYP. ESR 100 Hz (mΩ)	MAX. ESR 100 Hz (mΩ)	TYP. Z 10 kHz (mΩ)	MAX. Z 10 kHz (mΩ)	ORDERING CODE MAL2257.....	
									2-TERM.	3-TERM.
200	330	22 x 25	1.51	0.66	308	440	217	310	52331E3	62331E3
	390	22 x 30	1.74	0.78	259	370	182	260	52391E3	62391E3
	390	25 x 25	1.67	0.78	273	390	196	280	42391E3	72391E3
	470	22 x 35	2.00	0.94	238	340	175	250	52471E3	62471E3
	470	25 x 30	1.96	0.94	245	350	182	260	42471E3	72471E3
	470	30 x 25	1.93	0.94	266	380	203	290	32471E3	82471E3
	560	22 x 35	2.13	1.12	182	260	133	190	52561E3	62561E3
	560	25 x 30	2.06	1.12	196	280	140	200	42561E3	72561E3
	560	30 x 25	1.99	1.12	217	310	161	230	32561E3	82561E3
	680	22 x 40	2.44	1.36	154	220	112	160	52681E3	62681E3
	680	25 x 35	2.38	1.36	161	230	112	160	42681E3	72681E3
	820	22 x 45	2.76	1.64	126	180	91	130	52821E3	62821E3
	820	25 x 40	2.71	1.64	133	190	98	140	42821E3	72821E3
	820	30 x 30	2.44	1.64	147	210	112	160	32821E3	82821E3
	820	35 x 25	2.29	1.64	182	260	140	200	22821E3	12821E3
	1000	25 x 45	3.11	2.00	112	160	77	110	42102E3	72102E3
	1000	30 x 35	2.84	2.00	119	170	91	130	32102E3	82102E3
	1200	25 x 50	3.52	2.40	91	130	70	100	42122E3	72122E3
	1200	30 x 35	2.89	2.40	112	160	84	120	32122E3	82122E3
	1200	35 x 30	2.78	2.40	126	180	98	140	22122E3	12122E3
1500	30 x 45	3.60	3.00	84	120	63	90	32152E3	82152E3	
1500	35 x 35	3.22	3.00	98	140	77	110	22152E3	12152E3	
1800	30 x 50	4.03	3.60	70	100	56	80	32182E3	82182E3	
1800	35 x 40	3.57	3.60	84	120	70	100	22182E3	12182E3	
2200	35 x 45	3.96	4.40	70	100	56	80	22222E3	12222E3	
2700	35 x 50	4.36	5.40	63	90	49	70	22272E3	12272E3	
3300	35 x 60	5.05	6.60	49	70	42	60	22332E3	12332E3	
250	220	22 x 25	1.32	0.55	378	540	252	360	53221E3	63221E3
	270	25 x 25	1.50	0.68	322	460	210	300	43271E3	73271E3
	330	22 x 30	1.66	0.83	252	360	168	240	53331E3	63331E3
	390	22 x 35	1.90	0.98	217	310	140	200	53391E3	63391E3
	390	25 x 30	1.85	0.98	224	320	147	210	43391E3	73391E3
	470	22 x 40	2.17	1.18	182	260	119	170	53471E3	63471E3
	470	30 x 25	1.88	1.18	217	310	154	220	33471E3	83471E3
	560	22 x 45	2.45	1.40	154	220	98	140	53561E3	63561E3
	560	25 x 35	2.25	1.40	161	230	112	160	43561E3	73561E3
	560	30 x 30	2.25	1.40	168	240	119	170	33561E3	83561E3
	680	25 x 45	2.78	1.70	126	180	84	120	43681E3	73681E3
	680	30 x 35	2.60	1.70	140	200	98	140	33681E3	83681E3
	680	35 x 25	2.16	1.70	189	270	140	200	23681E3	13681E3
	820	25 x 50	3.17	2.05	105	150	70	100	43821E3	73821E3
	820	35 x 30	2.64	2.05	140	200	105	150	23821E3	13821E3
	1000	30 x 40	3.02	2.50	105	150	77	110	33102E3	83102E3
	1200	30 x 45	3.4	3.00	91	130	63	90	33122E3	83122E3
	1200	35 x 35	3.06	3.00	105	150	77	110	23122E3	13122E3
	1500	35 x 45	3.78	3.75	77	110	56	80	23152E3	13152E3
	1800	35 x 50	4.18	4.50	70	100	49	70	23182E3	13182E3
2200	35 x 55	4.48	5.50	63	90	49	70	23222E3	13222E3	



ELECTRICAL DATA AND ORDERING INFORMATION										
U _R (V)	C _R 100 Hz (μF)	NOMINAL CASE SIZE Ø D x L (mm)	I _R 100 Hz (A)	I _{L5} (mA)	TYP. ESR 100 Hz (mΩ)	MAX. ESR 100 Hz (mΩ)	TYP. Z 10 kHz (mΩ)	MAX. Z 10 kHz (mΩ)	ORDERING CODE MAL2257.....	
									2-TERM.	3-TERM.
400	82	22 x 25	0.78	0.33	1512	2160	1232	1760	56829E3	66829E3
	120	22 x 30	0.98	0.48	1036	1480	847	1210	56121E3	66121E3
	120	25 x 25	0.98	0.48	1050	1500	861	1230	46121E3	76121E3
	150	22 x 35	1.14	0.60	826	1180	672	960	56151E3	66151E3
	180	22 x 40	1.31	0.72	693	990	567	810	56181E3	66181E3
	180	25 x 30	1.23	0.72	700	1000	574	820	46181E3	76181E3
	180	30 x 25	1.27	0.72	721	1030	602	860	36181E3	86181E3
	220	22 x 45	1.50	0.88	567	810	462	660	56221E3	66221E3
	220	25 x 35	1.42	0.88	574	820	469	670	46221E3	76221E3
	270	25 x 40	1.64	1.08	469	670	385	550	46271E3	76271E3
	270	30 x 30	1.59	1.08	490	700	406	580	36271E3	86271E3
	270	35 x 25	1.63	1.08	518	740	441	630	26271E3	16271E3
	330	25 x 45	1.90	1.32	385	550	315	450	46331E3	76331E3
	330	30 x 35	1.83	1.32	399	570	329	470	36331E3	86331E3
	390	30 x 40	2.06	1.56	336	480	280	400	36391E3	86391E3
	390	35 x 30	1.99	1.56	364	520	308	440	26391E3	16391E3
	470	30 x 45	2.34	1.88	280	400	231	330	36471E3	86471E3
	470	35 x 35	2.27	1.88	294	420	252	360	26471E3	16471E3
	560	30 x 50	2.64	2.24	238	340	196	280	36561E3	86561E3
	560	35 x 40	2.54	2.24	252	360	210	300	26561E3	16561E3
680	35 x 45	2.84	2.72	210	300	175	250	26681E3	16681E3	
820	35 x 50	3.18	3.28	175	250	147	210	26821E3	16821E3	
1000	35 x 60	3.69	4.00	147	210	119	170	26102E3	16102E3	
450	68	22 x 25	0.71	0.31	1834	2620	1505	2150	57689E3	67689E3
	100	22 x 30	0.90	0.45	1246	1780	1029	1470	57101E3	67101E3
	100	25 x 25	0.90	0.45	1260	1800	1043	1490	47101E3	77101E3
	120	22 x 35	1.03	0.54	1036	1480	854	1220	57121E3	67121E3
	120	25 x 30	1.03	0.54	1043	1490	861	1230	47121E3	77121E3
	150	22 x 40	1.20	0.68	833	1190	686	980	57151E3	67151E3
	150	30 x 25	1.18	0.68	868	1240	721	1030	37151E3	87151E3
	180	25 x 35	1.30	0.81	700	1000	581	830	47181E3	77181E3
	220	25 x 45	1.59	0.99	574	820	476	680	47221E3	77221E3
	220	30 x 30	1.47	0.99	595	850	497	710	37221E3	87221E3
	220	35 x 25	1.52	0.99	623	890	525	750	27221E3	17221E3
	270	25 x 50	1.84	1.22	469	670	385	550	47271E3	77271E3
	270	30 x 35	1.69	1.22	483	690	399	570	37271E3	87271E3
	270	35 x 30	1.77	1.22	497	710	420	600	27271E3	17271E3
	330	30 x 40	1.92	1.49	399	570	329	470	37331E3	87331E3
	390	30 x 45	2.17	1.76	336	480	280	400	37391E3	87391E3
	390	35 x 35	2.13	1.76	350	500	294	420	27391E3	17391E3
	470	35 x 40	2.39	2.12	294	420	245	350	27471E3	17471E3
	560	35 x 45	2.66	2.52	245	350	210	300	27561E3	17561E3
	680	35 x 55	3.13	3.06	203	290	168	240	27681E3	17681E3



ELECTRICAL DATA AND ORDERING INFORMATION										
U _R (V)	C _R 100 Hz (μF)	NOMINAL CASE SIZE Ø D x L (mm)	I _R 100 Hz (A)	I _{L5} (mA)	TYP. ESR 100 Hz (mΩ)	MAX. ESR 100 Hz (mΩ)	TYP. Z 10 kHz (mΩ)	MAX. Z 10 kHz (mΩ)	ORDERING CODE MAL2257.....	
									2-TERM.	3-TERM.
500	56	22 x 25	0.67	0.28	2618	3740	2268	3240	59569E3	69569E3
	82	22 x 30	0.85	0.41	1792	2560	1554	2220	59829E3	69829E3
	82	25 x 25	0.85	0.41	1806	2580	1568	2240	49829E3	79829E3
	100	22 x 35	0.97	0.50	1470	2100	1274	1820	59101E3	69101E3
	100	25 x 30	0.98	0.50	1477	2110	1281	1830	49101E3	79101E3
	120	22 x 40	1.12	0.60	1225	1750	1064	1520	59121E3	69121E3
	120	30 x 25	1.10	0.60	1253	1790	1092	1560	39121E3	89121E3
	150	25 x 35	1.23	0.75	987	1410	861	1230	49151E3	79151E3
	180	25 x 40	1.41	0.90	826	1180	714	1020	49181E3	79181E3
	180	30 x 30	1.39	0.90	840	1200	735	1050	39181E3	89181E3
	180	35 x 25	1.44	0.90	868	1240	770	1100	29181E3	19181E3
	220	25 x 50	1.72	1.10	672	960	588	840	49221E3	79221E3
	220	30 x 35	1.59	1.10	686	980	602	860	39221E3	89221E3
	220	35 x 30	1.68	1.10	700	1000	616	880	29221E3	19221E3
	270	30 x 40	1.82	1.35	560	800	490	700	39271E3	89271E3
	330	30 x 45	2.08	1.65	462	660	406	580	39331E3	89331E3
	330	35 x 35	2.05	1.65	476	680	420	600	29331E3	19331E3
	390	30 x 50	2.34	1.95	392	560	343	490	39391E3	89391E3
	390	35 x 40	2.28	1.95	406	580	357	510	29391E3	19391E3
	470	35 x 45	2.55	2.35	336	480	294	420	29471E3	19471E3
560	35 x 50	2.85	2.80	287	410	252	360	29561E3	19561E3	
680	35 x 60	3.31	3.40	231	330	210	300	29681E3	19681E3	

ADDITIONAL ELECTRICAL DATA		
PARAMETER	CONDITIONS	VALUE
Voltage		
Surge voltage	≥ 400 V versions	U _s = 1.1 x U _R
	≤ 250 V versions	U _s = 1.15 x U _R
Reverse voltage		≤ 1 V
Current		
Leakage current	After 5 min at U _R	I _{L5} ≤ 0.01 C _R x U _R
Inductance		
Equivalent series inductance (ESL)	All case sizes	Typ. 19 nH
		Max. 25 nH

RIPPLE CURRENT AND USEFUL LIFE

Table 3

ENDURANCE TEST DURATION AND USEFUL LIFE	
ENDURANCE AT 85 °C (h)	USEFUL LIFE AT 85 °C (h)
3000	5000

Note

- Multiplier of useful life code: MGA453

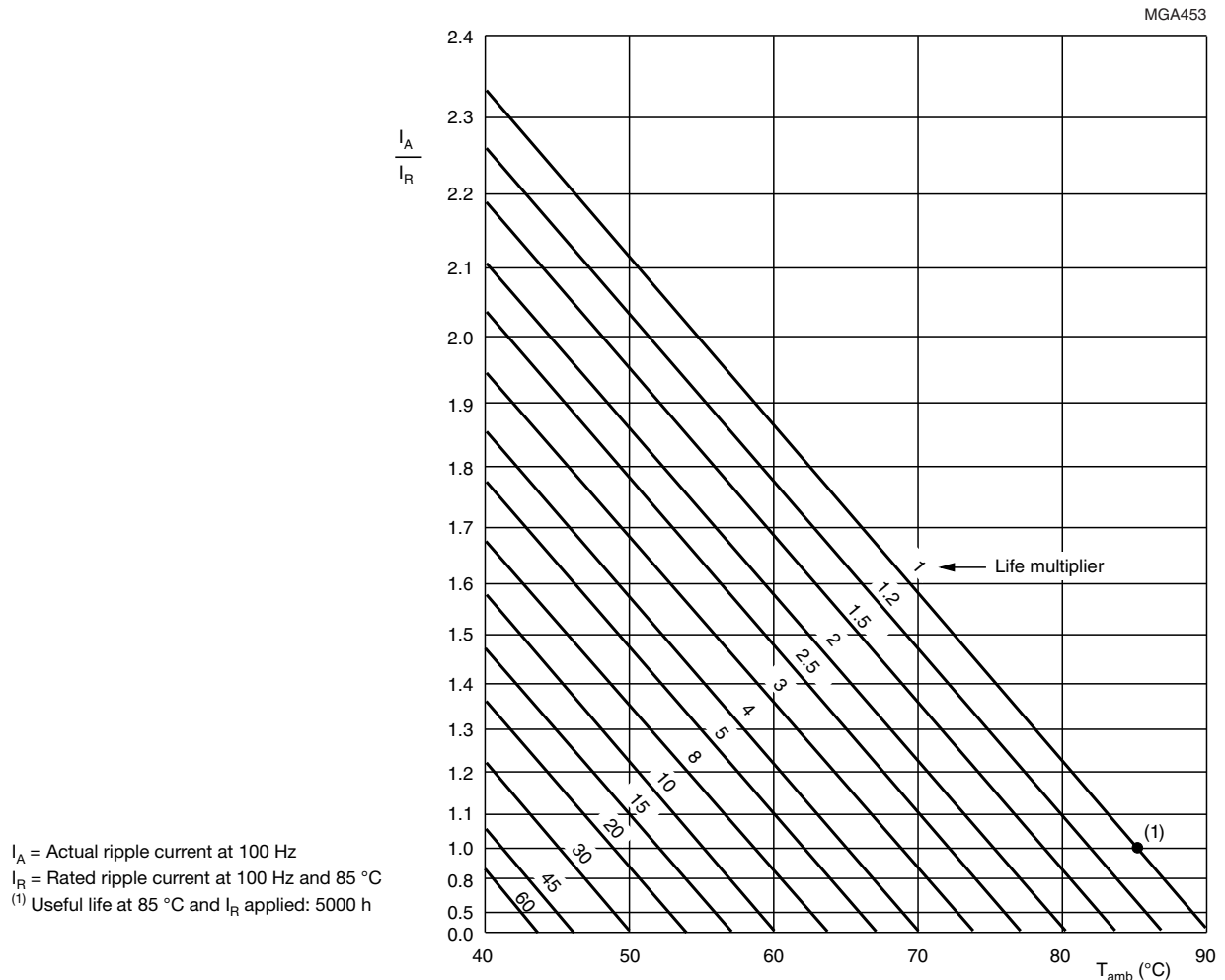

Fig. 6 - Multiplier of useful life as a function of ambient temperature and ripple current load

Table 4

MULTIPLIER OF RIPPLE CURRENT (I_R) AS A FUNCTION OF FREQUENCY					
FREQUENCY (Hz)					
50	100	120	200	1000	≥ 10 000
I_R MULTIPLIER					
0.80	1.00	1.05	1.20	1.30	1.40



Table 5

TEST PROCEDURES AND REQUIREMENTS			
TEST		PROCEDURE (quick reference)	REQUIREMENTS
NAME OF TEST	REFERENCE		
Endurance	IEC 60384-4 / EN 130300 subclause 4.13	$T_{amb} = 85\text{ }^{\circ}\text{C}$; U_R applied; 3000 h	$\Delta C/C: \pm 15\%$ $ESR \leq 1.3 \times \text{spec. limit}$ $I_{L5} \leq \text{spec. limit}$
Useful life	CECC 3030 subclause 1.8.1	$T_{amb} = 85\text{ }^{\circ}\text{C}$; U_R and I_R applied; 5000 h	$\Delta C/C: \pm 30\%$ $ESR \leq 3 \times \text{spec. limit}$ $I_{L5} \leq \text{spec. limit}$
Shelf life (storage at high temperature)	IEC 60384-4 / EN 130300 subclause 4.17	$T_{amb} = 85\text{ }^{\circ}\text{C}$; no voltage applied; 1000 h After test: U_R to be applied for 30 min, 24 h to 48 h before measurement	$\Delta C/C: \pm 15\%$ $ESR \leq 1.5 \times \text{spec. limit}$ $I_{L5} \leq \text{spec. limit}$

Statements about product lifetime are based on calculations and internal testing. They should only be interpreted as estimations. Also due to external factors, the lifetime in the field application may deviate from the calculated lifetime. In general, nothing stated herein shall be construed as a guarantee of durability.



Disclaimer

ALL PRODUCT, PRODUCT SPECIFICATIONS AND DATA ARE SUBJECT TO CHANGE WITHOUT NOTICE TO IMPROVE RELIABILITY, FUNCTION OR DESIGN OR OTHERWISE.

Vishay Intertechnology, Inc., its affiliates, agents, and employees, and all persons acting on its or their behalf (collectively, "Vishay"), disclaim any and all liability for any errors, inaccuracies or incompleteness contained in any datasheet or in any other disclosure relating to any product.

Vishay makes no warranty, representation or guarantee regarding the suitability of the products for any particular purpose or the continuing production of any product. To the maximum extent permitted by applicable law, Vishay disclaims (i) any and all liability arising out of the application or use of any product, (ii) any and all liability, including without limitation special, consequential or incidental damages, and (iii) any and all implied warranties, including warranties of fitness for particular purpose, non-infringement and merchantability.

Statements regarding the suitability of products for certain types of applications are based on Vishay's knowledge of typical requirements that are often placed on Vishay products in generic applications. Such statements are not binding statements about the suitability of products for a particular application. It is the customer's responsibility to validate that a particular product with the properties described in the product specification is suitable for use in a particular application. Parameters provided in datasheets and / or specifications may vary in different applications and performance may vary over time. All operating parameters, including typical parameters, must be validated for each customer application by the customer's technical experts. Product specifications do not expand or otherwise modify Vishay's terms and conditions of purchase, including but not limited to the warranty expressed therein.

Hyperlinks included in this datasheet may direct users to third-party websites. These links are provided as a convenience and for informational purposes only. Inclusion of these hyperlinks does not constitute an endorsement or an approval by Vishay of any of the products, services or opinions of the corporation, organization or individual associated with the third-party website. Vishay disclaims any and all liability and bears no responsibility for the accuracy, legality or content of the third-party website or for that of subsequent links.

Vishay products are not designed for use in life-saving or life-sustaining applications or any application in which the failure of the Vishay product could result in personal injury or death unless specifically qualified in writing by Vishay. Customers using or selling Vishay products not expressly indicated for use in such applications do so at their own risk. Please contact authorized Vishay personnel to obtain written terms and conditions regarding products designed for such applications.

No license, express or implied, by estoppel or otherwise, to any intellectual property rights is granted by this document or by any conduct of Vishay. Product names and markings noted herein may be trademarks of their respective owners.