

Multifunction display **CODIX 524**

programmable as:

- Pulse counter
- Position display
- Frequency / speed display
- Timer/ short time meter

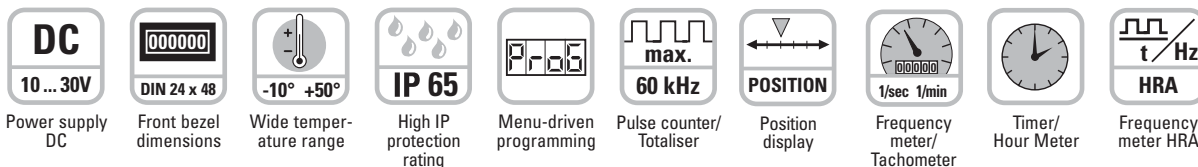

Powerful

- **Fast count input**
Input frequency max. 60 kHz
- **Robust housing**
IP 65 protection
- **LED display**
Very bright, 8 mm high
- **HRA – High Rate Accuracy System**
Frequencies up to 38 Hz are calculated using time-interval (period duration) measurement.
Frequencies > 38 Hz are calculated using a special time base (gate time) measurement. A very high accuracy of > 0.1% is achieved, even with very short gate times. The resulting measurement is available after a max. of 50 ms.
- **Fast start-up time**
Detects incoming pulses just 16 ms after being switched on – so no pulses are lost with a simultaneous motor start-up



User-friendly

- **Big keys**
Can also be operated when using gloves
- **Easy to programme**
Easy menu-driven programming and operation
Possibility to enter the programming mode during operation, with authentication query

Universal

- **Individually programmable scaling**
Multiplication and division factor (0.0001 to 99.9999), to display corresponding engineering units, e.g. position in 1/10 mm and speed in RPM
- **4 different count input modes**
2-channel input for detecting count direction, difference or adding mode, quadrature x1, x2 or x4
- **Frequency measurement**
Display in 1/min or 1/sec
- **Time counting**
Pulse width or time interval measurement in hours, minutes or seconds, as well as real-time display
- **DC power supply**
- **Inputs**
As an alternative to the HTL inputs, devices with a 5 VDC input trigger level are available, for use as parallel displays for PLCs.
- **Optional output**
Zero signal for position and count, zero-speed monitoring, 1 Hz clock pulse for active time measurement

Applications for Multi-function Display

- Counting tasks such as quantity and piece counting, measuring and recording of speed and of operating and processing times
- Piece counting or tool-life measurement on die cutters, presses, extruders, wood-working machines, drilling machines,

- pick-and-place machines, guillotines, special-purpose vehicles etc.
- Positioning tasks on processing machines, such as sawing machines, milling machines, bending and folding machines, etc.

- Production data acquisition by means of piece counting (using difference or adding), or measurement of production times or production speeds
- Totalizing flow, quantity and other scaleable media, or display of current flow rates

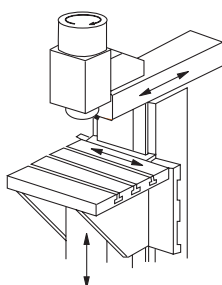

Position or rotary speed on milling machine

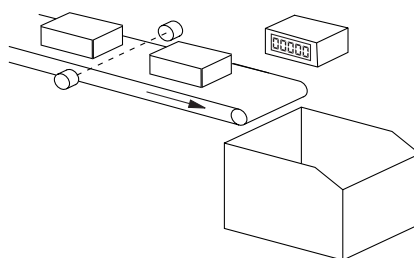

Piece count on conveyor or production speed

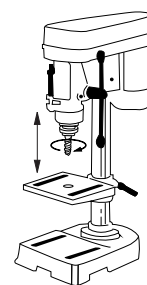

Drilling machine head, speed or drilling depth

Multifunction display *CODIX 524*

Technical data:

Supply voltage:	10 ... 30 V DC, with reverse polarity protection	Level of inputs:	Low: 0 ... 0.2 x U _B [V DC] High: 0.6 x U _B ... 30 V DC
Current consumption:	max. 50 mA	Level of inputs:	Low: 0 ... 2 V DC
Display:	6 digit red 7-segment LED; 8 mm [0.315"] high	5 V version:	High: 4 ... 30 V DC
Data backup:	EEPROM	Optocoupler output:	Max. 30 V, 10 mA
Housing:	dimension 48 x 24 mm [1.89 x 0.945"] according to DIN 43 700; RAL 7021, grey	Accuracy:	tachometer: <0.1 % timer: 50 ppm
Polarity of inputs:	programmable, npn or pnp for all inputs	EMC:	according to EC EMC directive 89/36/EWG
Input resistance:	approx. 5 kΩ	Immunity to interference:	EN 61000-6-4/EN 55011 class B
Counting frequency:	60 kHz, can be damped to 30 Hz	Emitted interference:	EN 61000-6-2
Display range timer:	0.001 s ... 999999 h	Ambient temperature:	-10 ... +50 °C [14 ... 122 °F]
Reset time:	5 ms	Storage temperature:	-25 ... +70 °C [-13 ... 158 °F]
		Protection:	IP 65 front side
		Weight:	approx. 50 g [1.764 oz]

Block diagram:

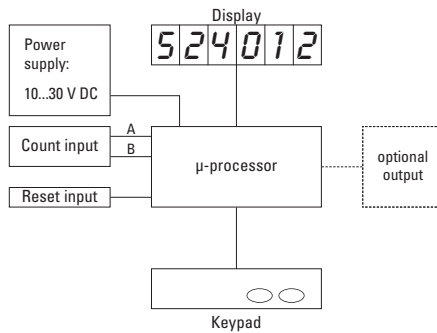

Dimensions:

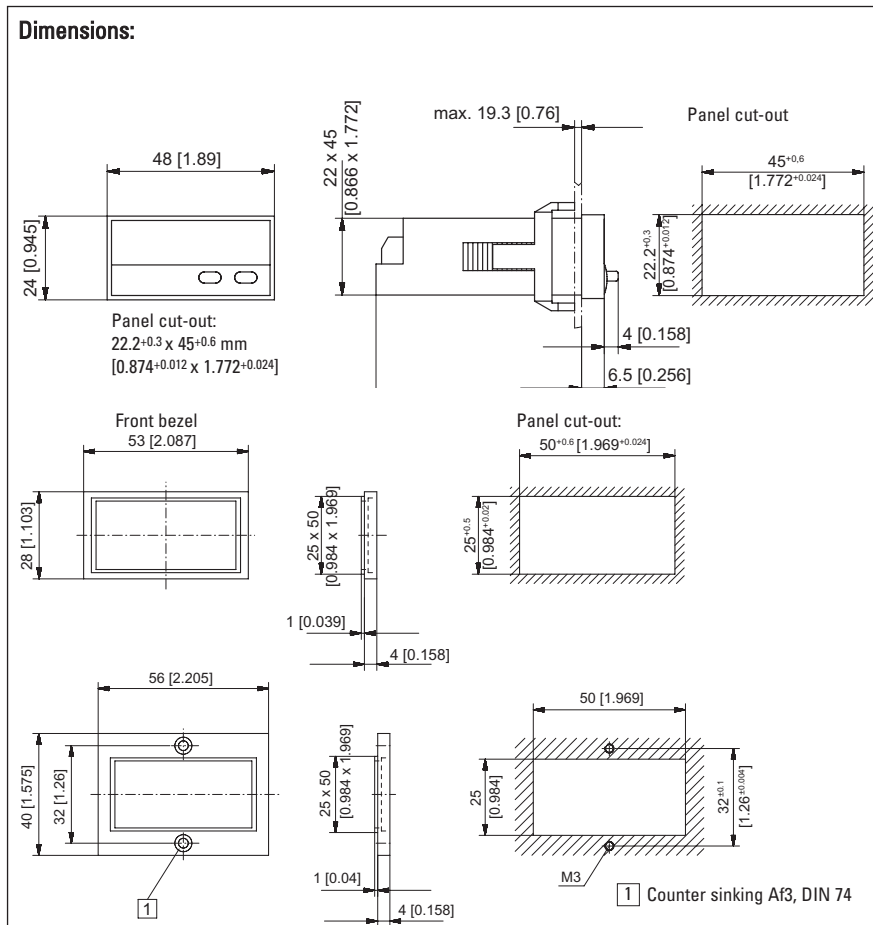

Connections:

without optocoupler

- 1 10 ... 30 V DC
- 2 0 V GND
- 3 INP A
- 4 INP B
- 5 Reset

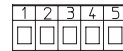

Connections:

with optocoupler

- 1 10 ... 30 V DC
- 2 0 V GND
- 3 INP A
- 4 INP B
- 5 RESET
- 6 Emitter
- 7 Collector

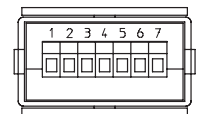

Delivery specifications:

- 1 Digital display
- 1 Panel mounting clip
- 1 Bezel for screw mounting, panel cut out 50 x 25 mm [1.969 x 0.984"]
- 1 Bezel for clip mounting, panel cut out 50 x 25 mm [1.969 x 0.984"]
- 1 Seal
- 1 Multilingual operating instructions

Order code:

6.524.01X.3X0

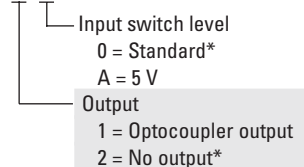

* standard stock model