

THIS DRAWING IS UNPUBLISHED. RELEASED FOR PUBLICATION, 19 .  
 © COPYRIGHT 19 BY AMP INCORPORATED. ALL INTERNATIONAL RIGHTS RESERVED.

| LOC | DIST | P | F | ZONE | LTR | DESCRIPTION                 | DATE   | APPD    |
|-----|------|---|---|------|-----|-----------------------------|--------|---------|
| G   | 14   |   |   |      | H   | ADDED 2-35135-2 PER PR 94-6 | 2/2/94 | OKS DAP |

**METRIC**  
 DIMENSIONS LISTED IN mm [ INCHES ]

|                                |                            |
|--------------------------------|----------------------------|
| <b>AMP</b><br>WIRE RANGE       | <b>UL</b> E13288<br>Listed |
| 12-10 AWG<br>SOLID OR STRANDED | 12-10 AWG<br>STRANDED      |
| <b>SR</b> LR7189<br>Certified  | MILITARY P/N<br>AND CLASS  |
| 12-10 AWG<br>SOLID OR STRANDED | MS 20659-166<br>CLASS 2    |

1 STAMP AMP 12-10\* APPROX AS SHOWN

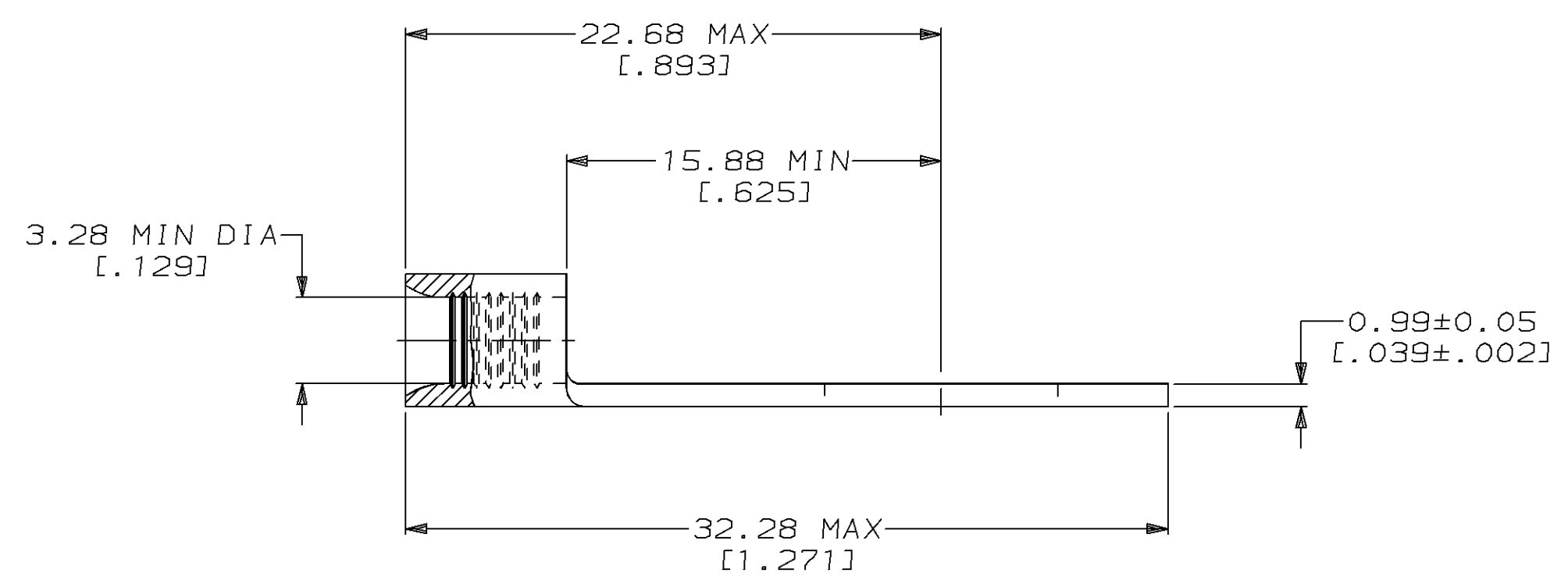
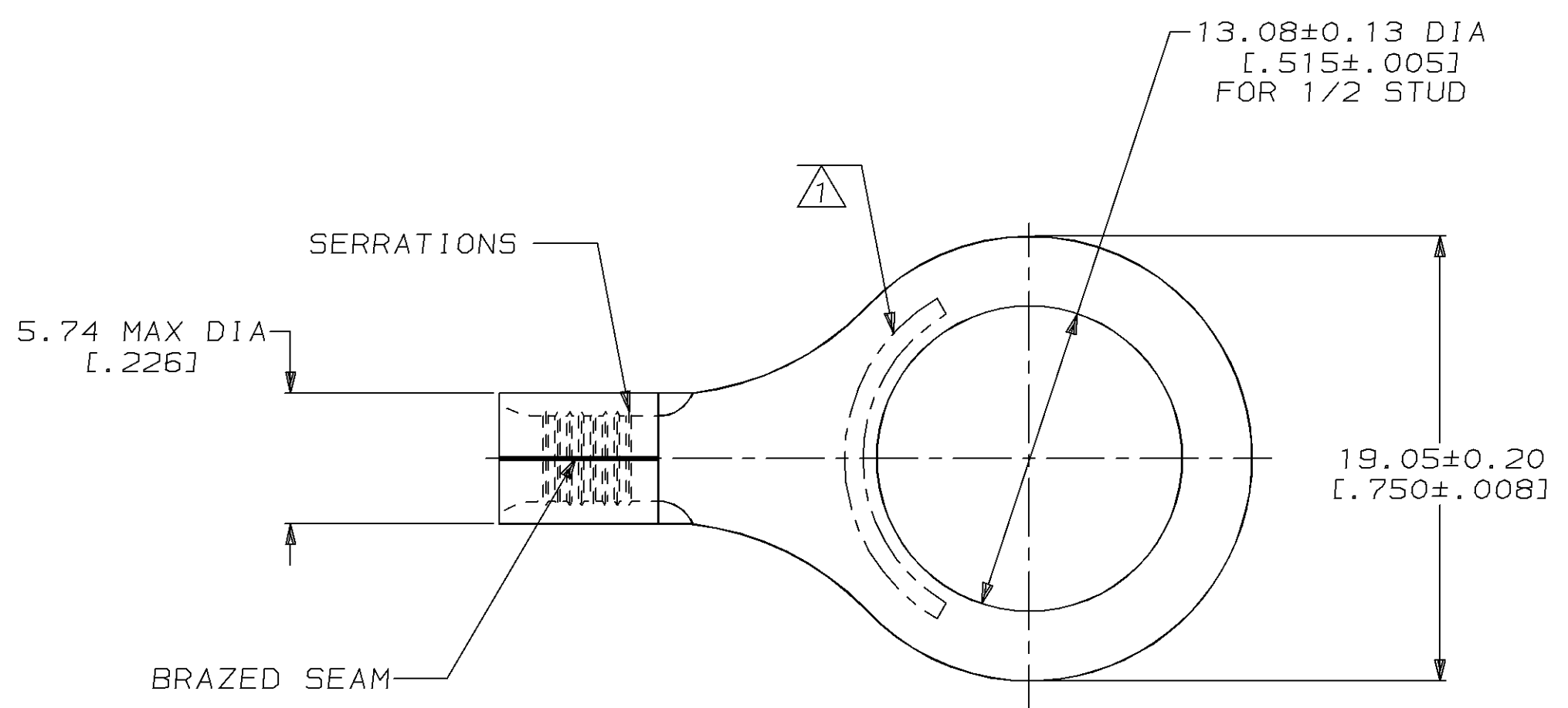

| 1000 | TAPE MOUNTED | 2-35135-2 |
|------|--------------|-----------|
| 500  | LOOSE PIECE  | 35135     |
| QTY  | PACKAGE TYPE | PART NO   |

**AMP INCORPORATED**  
**CUSTOMER SERVICE SYSTEMS**

MAX RECOMMENDED OPERATING TEMPERATURE:  
 170°C MAX

DO NOT SCALE PRINT. UNLESS SPECIFIED  
 DIMENSIONS IN mm [INCHES]  
 TOLERANCES ON:  
 2 PLC DEC ± -  
 3 PLC DEC ± -  
 ANGLES ± -

DR 3-17-93  
 TA BRINKMAN  
 CHK 3-17-93  
 DA PATTERSON  
 APPD 3-17-93  
 DE MILLER  
 APPD 3-17-93  
 JL MECKLEY  
 PRODUCT SPEC -

**AMP** AMP Incorporated  
 Harrisburg, PA 17105-3608

FOR ADDITIONAL PRODUCT INFORMATION OR COPIES OF DRAWINGS AND TECHNICAL DOCUMENTS

PRODUCT INFORMATION CENTER  
 1-800-522-6752

VOLTAGE RATING:  
 NOT APPLICABLE

MATERIAL  
 COPPER PER ASTM B-152 ANNEALED

APPLICATION SPEC -

NAME  
**TERMINAL, RING TONGUE, SOLISTRAND™**

FOR APPLICATION TOOLING INFORMATION

TOOLING ASSISTANCE CENTER  
 1-800-722-1111

WIRE CROSS SECTIONAL AREA RANGE:  
 2.62-6.64mm² [5, 180-13, 100] CIR MILS  
 SOLID OR STRANDED

FINISH  
 TIN PLATE  
 0.00254 [0.000100] MIN THK PER MIL-T-10727

WEIGHT -

SIZE CAGE CODE DRAWING NO  
 C 00779 C=35135  
 SCALE 4:1 SHEET 1 OF 1

THIS DRAWING IS A CONTROLLED DOCUMENT FOR AMP INCORPORATED. IT IS SUBJECT TO CHANGE AND THE CONTROLLING ENGINEERING ORGANIZATION SHOULD BE CONTACTED FOR THE LATEST REVISION.