

SYMBOL DEFINITION		TOTAL NO OF INSPECTIONS REQUIRED	NO MISSING SYMBOL NUMBER
A DIMENSION WITHOUT AN INSPECTION REPORT SYMBOL DOES NOT REQUIRE INSPECTION. IT MAY BE CONTROLLED ON THE INDIVIDUAL COMPONENT DRAWING.		8	
	LAST NO. USED	8	

DWG STATUS				REVISION HISTORY				AUTH				
DATE	STG	REV	N/P	CHG	ZONE				DR	AP/VD		
11JL01	R	01	-	-		ALL ACTIVE PARTS - REVISED GRAPHICS				211315	RVP/RVP	JH
17JL03	R	02	-	-		12020156 - PER ECN 211315 REV LEVEL L2 SHOULD BE K1, CORRECT REV LEVEL TO K2				243603	JYD/JYD	JH
01AU06	R	03	-	-		12020156, 12033997 & 12066614 - MAT'L SPEC WAS P1519030				283052	MDH/JAA	MKM

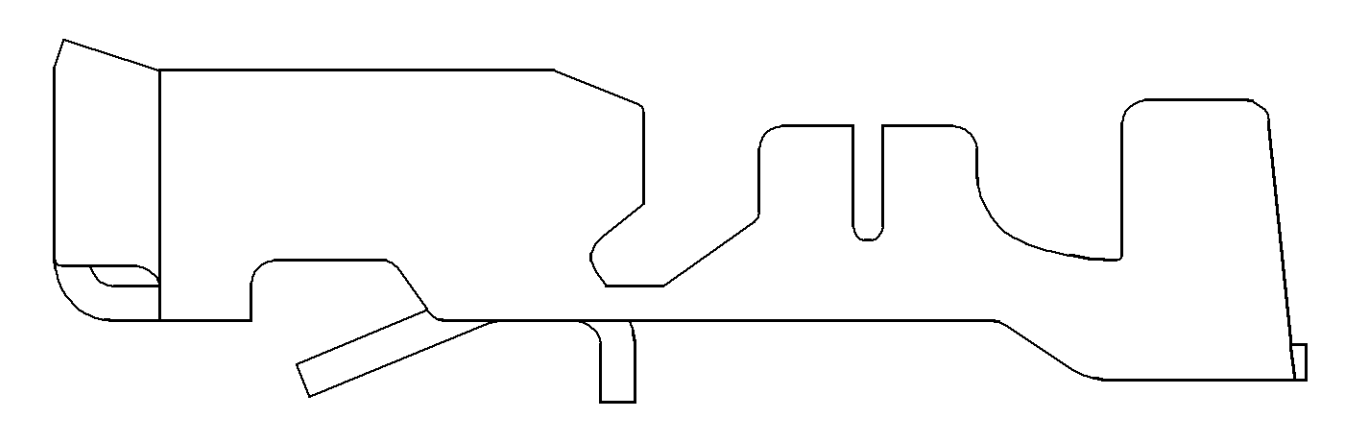

TYPE 102
SAME AS TYPE 101
EXCEPT AS SHOWN

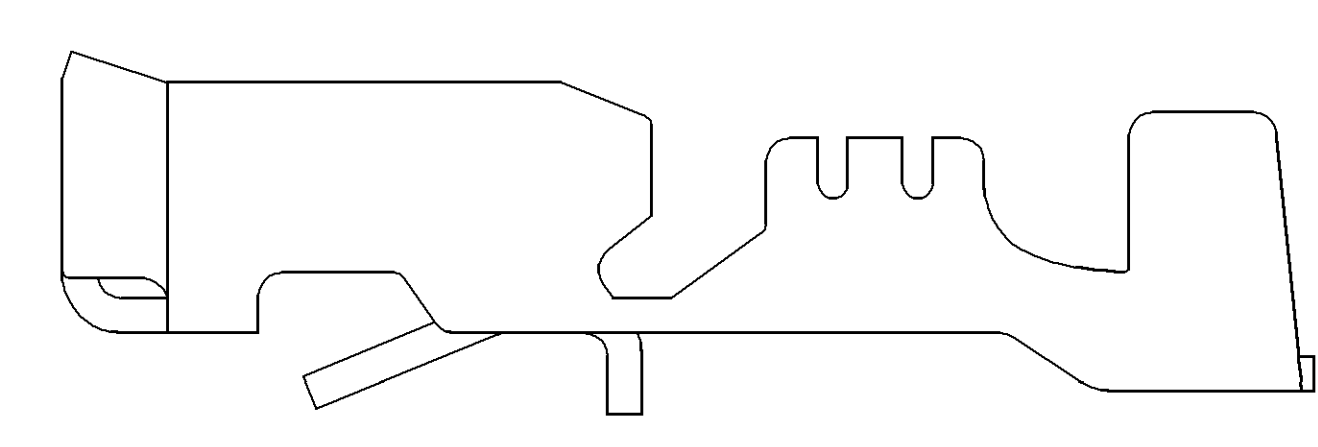

TYPE 103
SAME AS TYPE 101
EXCEPT AS SHOWN

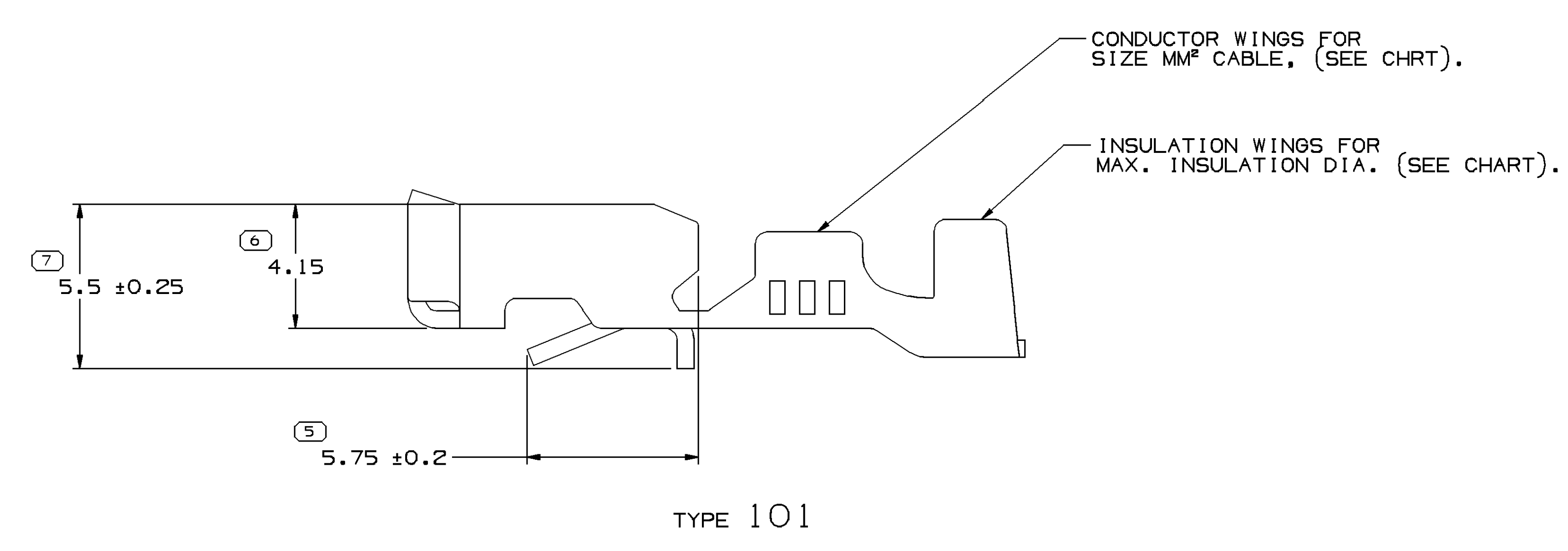
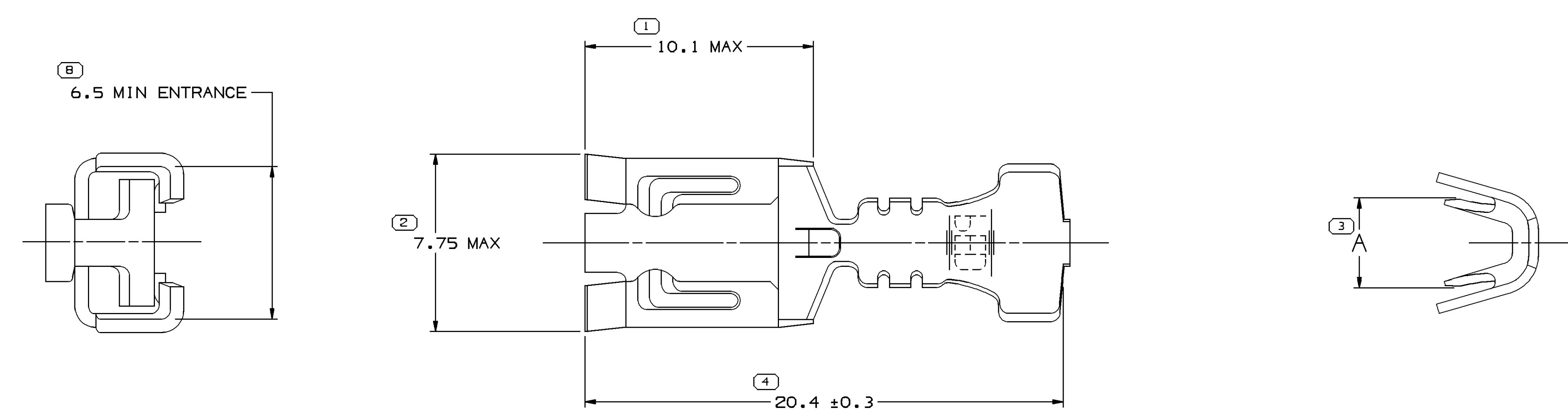

NOTES

- UNLESS OTHERWISE SPECIFIED AND/OR INDICATED:
DIMENSIONS ARE TO FACE OF VIEW SHOWN AND AUTOMATICALLY ROUNDED BY COMPUTER FOR INSPECTION (SEE MATH MODEL FOR PRECISE DIMENSIONS). FOR ALL OTHER DIMENSIONS NOT SHOWN BUT REQUIRED FOR TOOL BUILD, SEE MATH MODEL FOR PRECISE TOOL PATH DATA.
- RECOMMENDED MATING BLADES - (1) METRI-PACK (0.86/0.79 THK. X 6.38/6.22 WIDE)
(2) AUTOFUSE (0.69/0.61 THK X 5.355/5.11 WIDE)
- THIS PART FOR DIAGNOSTIC INDUSTRY APPLICATIONS.

PART NO	REV	N/P	STATUS	MAT'L SIZE	MAT'L SPEC	PART NO	REV	N/P	STATUS	MAT'L SIZE	MAT'L SPEC	SIZE (MM²)	ID	DIA	TYPE
12066506	A	-	OBSOLETE	0.406 X 35.71	S1519030 TIN BRS EX HD SLIT	12176854	A2	-		0.406 X 35.71	PM003658-030 17410 BE CU 1/2 HT A6/N1 PLTD	5 - 3	11	4.48-2.74	102 4.6
12066505	B	-	OBSOLETE	0.406 X 35.71	S1519030 TIN BRS EX HD SLIT	12020156	K3	-		0.406 X 35.71	M1574030 NONFERROUS C42500 EX HD	0.8 - 0.5	19	3.13-1.87	103 3.2
12066504	B	-	OBSOLETE	0.406 X 35.71	S1519030 TIN BRS EX HD SLIT	12066614	A2	-		0.406 X 35.71	M1574030 NONFERROUS C42500 EX HD	2 - 1	15	3.97-3.14	102 3.7
						12033997	E3	-		0.406 X 35.71	M1574030 NONFERROUS C42500 EX HD	3 - 1	12	3.68-2.94	102 4.6
						12020157	H	-	OBSOLETE	0.406 X 35.71	P1519030 TIN BRS EX HD SN PLTD	2 - 1	15	3.97-3.14	101 3.7

PART DRAWING	
STYLE	D
VOLUME 10/11	DISTR CODE
UNLESS OTHERWISE SPECIFIED	
THIS DOCUMENT IS IN ACCORDANCE WITH ASME Y14.5M-1994 AS MODIFIED BY THE IN-SITU DIMENSIONING AND TOLERANCE PRACTICES. SEPARATE NOTATIONS OF DIMENSIONS AND TOLERANCES MAY BE BASED SEPARATELY PER DELPHI REFERENCES.	
ALL DIMENSIONS ARE IN MILLIMETERS	

DELPHI
DELPHI PACKARD ELECTRIC SYSTEMS
WREN, OH

DR	DATE
APV01 J. KRAUSE	15MR88
APV02 D. STEELE	14AP88
APV03 G. SMALDINO	21AP88
APV04	

APV05 SUBSTANCES OF CONCERN AND RECYCLED CONTENT PER DELPHI 1094001

DRAWING NAME: TAXI TERM F M/P 630

DRAWING NUMBER: 12020155

SIZE: A0 SCALE: B:1 FRAME NO: 1 OF 1 SHEET NO: 1 OF 3 REV: N/P

(4) PROCESS SENSITIVE DIMENSION	
DIMENSIONS ENCLOSED IN () INDICATE REFERENCE DIMENSIONS AND NO TOLERANCE LIMITS ARE ESTABLISHED	
DIMENSIONAL RANGE (MM)	CHRT D
FROM 0 TO 12	>12
TOLERANCE UNLESS OTHERWISE SPECIFIED	
±0.1	±0.2
ANGULAR TOLERANCE 22°	

