

Current 13 Click

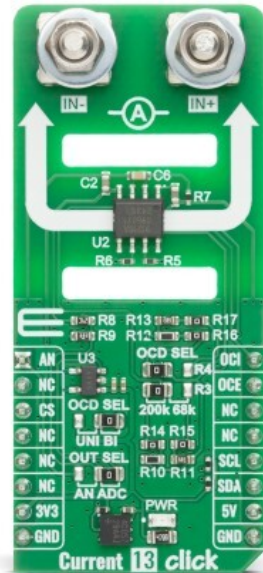

PID: MIKROE-6815

Current 13 Click is a compact add-on board designed for high-speed current measurement in demanding automotive and industrial applications. It is based on the [MLX91218](#) (MLX91218LDC-AFL-500), a high-accuracy IMC-Hall® current sensor IC from [Melexis](#) with integrated overcurrent detection (OCD) and AEC-Q100 Grade 0 automotive qualification. This IC features a dual overcurrent detection system with selectable unidirectional and bidirectional sensing modes, adjustable OCD threshold configuration via onboard jumpers, and flexible output selection between analog and digital conversion using the MCP3221 12-bit ADC. With a measurement range of $\pm 10\text{mT}$, current range up to 200A, 600mV/mT sensitivity, 400kHz bandwidth, and very low thermal drift, it ensures reliable operation even in fast-switching environments. Designed for use with the optional U-Shield Ni-Fe ferromagnetic core, Current 13 Click is ideal for high-voltage traction inverters, DC-DC converters, battery management systems, and smart fuse or overcurrent protection applications.

For more information about **Current 13 Click** visit the official [product page](#).

How does it work?

Current 13 Click is based on the MLX91218 (MLX91218LDC-AFL-500), a high-speed, high-accuracy IMC-Hall® current sensor IC with integrated overcurrent detection (OCD) from Melexis, designed for precise and fast current measurement in high-performance automotive and industrial applications. This monolithic Hall-effect sensor uses IMC-Hall® technology to provide an analog output voltage proportional to the magnetic flux density parallel to the IC surface. Its transfer characteristic is factory-trimmed over temperature to ensure exceptional linearity and accuracy, while key parameters such as offset, sensitivity, filtering, and internal

Mikroe produces entire development toolchains for all major microcontroller architectures.

Committed to excellency, we are dedicated to helping engineers bring the project development up to speed and achieve outstanding results.



ISO 27001: 2013 certification of informational security management system.
 ISO 14001: 2015 certification of environmental management system.
 OHSAS 18001: 2008 certification of occupational health and safety management system.



ISO 9001: 2015 certification of quality management system (QMS).

overcurrent threshold can be programmed during end-of-line calibration. Typical use cases include redundant current monitoring in battery management systems (BMS), phase and DC-link current measurement in high-voltage traction motor inverters, 48V boost recuperation inverters, DC-DC converters, smart battery junction boxes, and smart fuse overcurrent detection circuits.

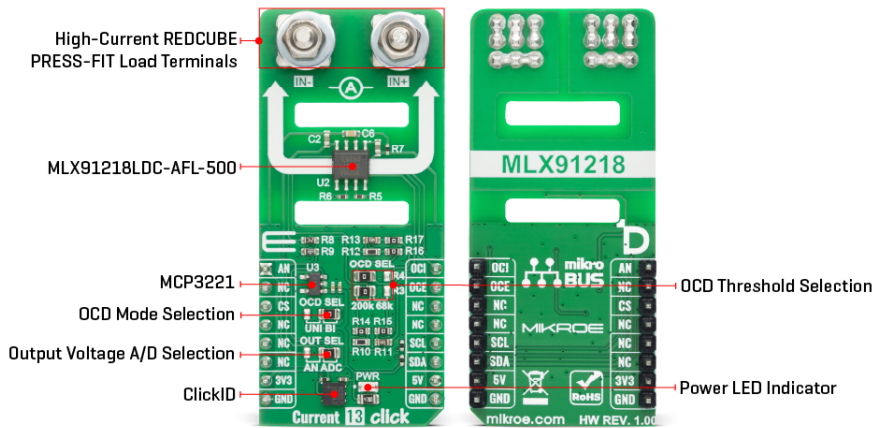

The MLX91218 offers a measurement range $\pm 10\text{mT}$, current from 1 to 200A, featuring a fixed output mode with a low-field IMC core, sensitivity of 600mV/mT, and an overcurrent detection level at 134.7% of full scale. With AEC-Q100 Grade 0 automotive qualification and extremely low thermal drift across a wide temperature range, this device ensures reliability and stability under demanding conditions. Thanks to its 400kHz bandwidth and ultra-fast response time, it is ideally suited for high-speed switching environments such as inverters, converters, and motor control systems that require rapid current feedback.

Current 13 Click features a dual overcurrent detection (OCD) configuration system that allows flexible adaptation to various application requirements. The board includes an OCD SEL jumper that provides two selectable modes: UNI and BI, enabling either unidirectional or bidirectional current sensing configuration. Additionally, the board integrates a dedicated set of OCD SEL jumpers labeled R3 and R4 that enable fine-tuning of the OCD threshold level. By adjusting these jumpers, users can define the desired overcurrent detection point according to system safety requirements and protection logic. Furthermore, two dedicated pins, OCI and OCE, provide feedback signals corresponding to overcurrent detection events based on the internal and external threshold levels, respectively.

The MLX91218's output signal can be converted to a digital value using [MCP3221](#), a successive approximation A/D converter with a 12-bit resolution from Microchip, using a 2-wire I2C compatible interface, or sent directly to an analog pin of the mikroBUS™ socket labeled as AN. Selection can be performed via an onboard SMD jumper labeled OUT SEL, placing it in an appropriate position marked as AN and ADC.

In a typical current sensing setup, Current 13 Click is designed to operate in combination with a U-shaped ferromagnetic shield, the [Ferromagnetic Shield U-Shield Ni-Fe](#), which MIKROE also provides as an accessory. By using this U-shaped shield, the MLX91218 sensor can be mounted directly over a bus bar while being electrically isolated from it by the PCB, allowing safe and accurate current measurement without direct electrical contact. The board includes a clearly marked placement area that matches the geometry of the U-Shield, ensuring straightforward and reliable mechanical integration.

Mikroe produces entire development toolchains for all major microcontroller architectures.

Committed to excellency, we are dedicated to helping engineers bring the project development up to speed and achieve outstanding results.



ISO 27001: 2013 certification of informational security management system.
 ISO 14001: 2015 certification of environmental management system.
 OHSAS 18001: 2008 certification of occupational health and safety management system.



ISO 9001: 2015 certification of quality management system (QMS).

This Click board™ can operate with either 3.3V or 5V logic voltage levels. The onboard design uses a dual-voltage scheme in which 5V is dedicated to powering the MLX91218 IC, providing stable operation and maintaining the sensor's specified accuracy and performance, while 3.3V is used for communication with the host MCU. The board must perform appropriate logic voltage level conversion before using MCUs with different logic levels. It also comes equipped with a library containing functions and example code that can be used as a reference for further development.

Specifications

Type	Current, Current sensor
Applications	Ideal for high-voltage traction inverters, DC-DC converters, battery management systems, and smart fuse or overcurrent protection applications
On-board modules	MLX91218LDC-AFL-500 - high speed high Accuracy IMC-Hall® current sensor IC in with OCD from Melexis
Key Features	High-speed and high-accuracy IMC-Hall® current sensor, dual OCD configuration with selectable unidirectional and bidirectional sensing modes, adjustable OCD threshold level, selectable analog or digital output, low thermal drift across a wide temperature range, AEC-Q100 Grade 0 automotive qualification, compatibility with U-Shield Ni-Fe ferromagnetic core for precise magnetic field focusing, and more
Interface	I2C
Feature	ClickID
Compatibility	mikroBUS™
Click board size	L (57.15 x 25.4 mm)
Input Voltage	3.3V, 5V

Pinout diagram

This table shows how the pinout on Current 13 Click corresponds to the pinout on the mikroBUS™ socket (the latter shown in the two middle columns).

Notes	Pin	mikroBUS				Pin	Notes
Analog Current Output	AN	1	AN	PWM	16	OCI	Internal Threshold Overcurrent Detection
	NC	2	RST	INT	15	OCE	External Threshold Overcurrent Detection
ID COMM	CS	3	CS	RX	14	NC	
	NC	4	SCK	TX	13	NC	
	NC	5	MISO	SCL	12	SCL	I2C Clock
	NC	6	MOSI	SDA	11	SDA	I2C Data

Mikroe produces entire development toolchains for all major microcontroller architectures.

Committed to excellency, we are dedicated to helping engineers bring the project development up to speed and achieve outstanding results.



ISO 27001: 2013 certification of informational security management system.
 ISO 14001: 2015 certification of environmental management system.
 OHSAS 18001: 2008 certification of occupational health and safety management system.



ISO 9001: 2015 certification of quality management system (QMS).

Power Supply	3.3V	7	3.3V	5V	10	5V	Power Supply
Ground	GND	8	GND	GND	9	GND	Ground

Onboard settings and indicators

Label	Name	Default	Description
LD1	PWR	-	Power LED Indicator
JP1	OUT SEL	Right	Output Voltage A/D Selection AN/ADC: Left position AN, Right position ADC
JP2	OCD SEL	Right	OCD Mode Selection UNI/BI: Left position UNI, Right position BI
JP3-JP4	OCD SEL	Left	OCD Threshold Selection 200k/68k: Left position 200k, Right position 68k

Current 13 Click electrical specifications

Description	Min	Typ	Max	Unit
Supply Voltage	3.3	-	5	V
Current Range	1	-	200	A
Operational Magnetic Field Range	-	-	±10	mT
Programmable Sensitivity	200	600	600	mV/mT

Software Support

[Current 13 Click](#) demo application is developed using the [NECTO Studio](#), ensuring compatibility with [mikroSDK](#)'s open-source libraries and tools. Designed for plug-and-play implementation and testing, the demo is fully compatible with all development, starter, and mikromedia boards featuring a [mikroBUS™](#) socket.

Example Description

This example demonstrates the use of Current 13 Click board by reading and displaying the input current measurements.

Key Functions

- `current13_cfg_setup` This function initializes Click configuration structure to initial values.
- `current13_init` This function initializes all necessary pins and peripherals used for this Click board.
- `current13_calib_offset` This function calibrates the zero current offset value.
- `current13_calib_resolution` This function calibrates the data resolution at the known load current.
- `current13_read_current` This function reads the input current level [A].

Application Init

Initializes the driver and calibrates the zero current offset and data resolution at 3A load

Mikroe produces entire development toolchains for all major microcontroller architectures.

Committed to excellency, we are dedicated to helping engineers bring the project development up to speed and achieve outstanding results.



ISO 27001: 2013 certification of informational security management system.
 ISO 14001: 2015 certification of environmental management system.
 OHSAS 18001: 2008 certification of occupational health and safety management system.



ISO 9001: 2015 certification of quality management system (QMS).

current.

Application Task

Reads the input current measurements and displays the results on the USB UART approximately once per second.

Application Output

This Click board can be interfaced and monitored in two ways:

- Application Output - Use the "Application Output" window in Debug mode for real-time data monitoring. Set it up properly by following [this tutorial](#).
- UART Terminal - Monitor data via the UART Terminal using a [USB to UART converter](#). For detailed instructions, check out [this tutorial](#).

Additional Notes and Information

The complete application code and a ready-to-use project are available through the NECTO Studio Package Manager for direct installation in the [NECTO Studio](#). The application code can also be found on the MIKROE [GitHub](#) account.

Resources

[mikroBUS™](#)

[mikroSDK](#)

[Click board™ Catalog](#)

[Click boards™](#)

[ClickID](#)

Downloads

[Current 13 click example package](#)

[MLX91218 datasheet](#)

[Current 13 click schematic v100](#)

[Current 13 click 2D and 3D files v100](#)

Mikroe produces entire development toolchains for all major microcontroller architectures.

Committed to excellency, we are dedicated to helping engineers bring the project development up to speed and achieve outstanding results.



ISO 27001: 2013 certification of informational security management system.
ISO 14001: 2015 certification of environmental management system.
OHSAS 18001: 2008 certification of occupational health and safety management system.



ISO 9001: 2015 certification of quality management system (QMS).