

Instructions for the Assembly of 3357 Metal/Metalized Plastic EMI/ESD Junction Shell

General:

The 3M 3357-XXXX EMI/ESD Junction Shell is used with the 3M Delta Connector System and round jacketed/shielded flat cable to provide EMI/ESD protection and a continuous path to ground. Different sizes of compression inserts accommodate a full range of cable sizes.

Assembly:

Braided Shield Cable

- 1 a. Select the tightest compression insert that can fit over the cable. The thin ring compression insert is for the largest size of cable. **Detach and slip insert on the cable.** If a very tight fit is encountered, the compression insert will become more flexible if heated immediately before slipping over the cable, or wet the cable slightly for lubrication.
- b. Slide the appropriate insert approximately 2 inches (1½" for the 3357-XX09) over the cable jacket (Fig. 1). NOTE: When using 3M cable 3659, determine the unsplit section of the cable and make the cut back dimensions from this point.
- c. Remove the jacket from the cable end for a distance of approximately 1½ inches. Cut and fold braid/jacket evenly over the smaller diameter portion of the insert. The jacket or braid should not overlap onto the large diameter of the insert. If the cable has a thin braid, fold back the jacket as shown (Fig. 2) and then fold shield over the jacket.

NOTE: For some cables use preparation as shown in Figure 3.

2. Assemble connector. See instructions on terminating Delta Connector on 3M cable included in connector packaging.

Caution

To prevent shorting of cable ends during installation of shell, use care not to allow cable to protrude beyond the edge of connector cover. For increased protection, position a thin film tape (such as 3M #56) over the exposed conductors. (See Figure 4.)

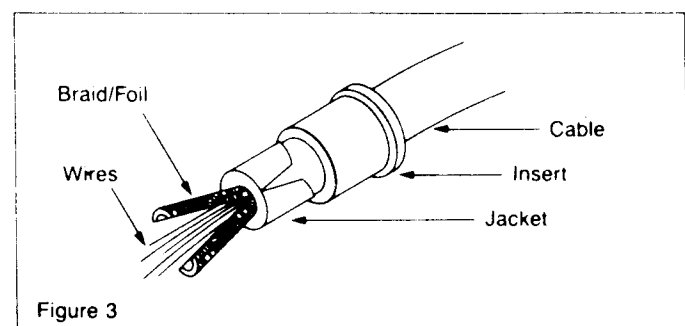
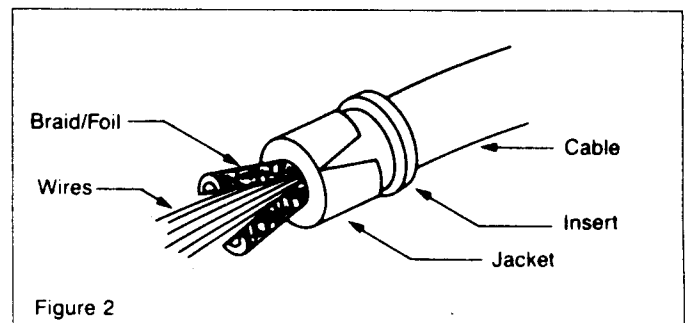
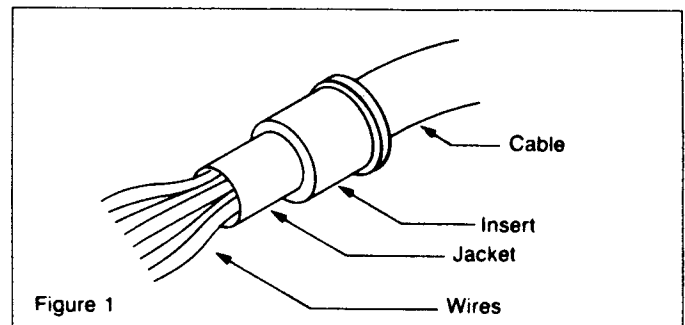

Foil Shield Cable

Follow the general assembly instructions for braided shield cable and/or follow cable preparation instructions.

- 1 a. Select the tightest compression insert that can fit over the cable. **Detach and slip insert onto cable.** If a very tight fit is encountered, the compression insert will become more flexible if heated immediately before slipping over the cable; or wet the cable slightly for lubrication.
- b. Slide the appropriate insert approximately 2 inches (1 1/2" for the 3357-XX09) over the cable jacket (see Fig. 1).
- c. Cut two parallel slits in the jacket and foil along each side of the cable (see Fig. 2). Use care as foil damages easily.

NOTE: A short blade, surgical type scissors is useful for this procedure.

- d. Fold the jacket and foil back, over the small diameter of the insert evenly. If the drain wire is outside the foil (i.e. if the conductive side of the foil is on the outside), fold the foil twice over the insert, so that the conductor is in contact with the metal shell. If there is too much jacket material over the insert, trim it by making V-shaped cuts in the slits. Trim off any shield or jacket material over the large diameter of the insert.
2. Assemble Connector: See instructions for terminating Delta connectors in connector packaging.

Caution

To prevent shorting of cable ends during installation of shell, use care not to allow cable to protrude beyond the edge of connector cover. For increased protection, position a thin film tape (such as 3M #56) over the exposed conductors. (See Fig. 4.)

3. Assemble connector and shell. See previous braid shielded cable assembly instructions (part 3a-d).

- 3 a. Assemble connector and shell. Place the connector and cable into the bottom shell. Hold the connector at an angle as shown in Figure 4. Press the tabs of the connector into the recess of the bottom cover and rock into place until a latching click is felt. Repeat for the top cover.
- Important:** Form the cable wires smoothly over the connector as shown in Figures 4 & 5.

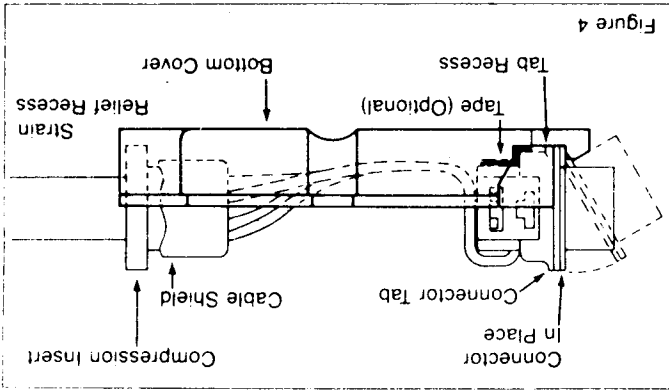

Figure 4

- b. With the junction shells slightly apart, position the compression insert into the strain relief recess. Take care to keep the shield folded back evenly over the insert (not over the large diameter) to provide electrical contact with the cover.
- c. While the covers are still separated, install the two (2) captive screws and saddle washers into the connector mounting flanges.
- d. Install the screws and nuts that secure the two junction shell halves.

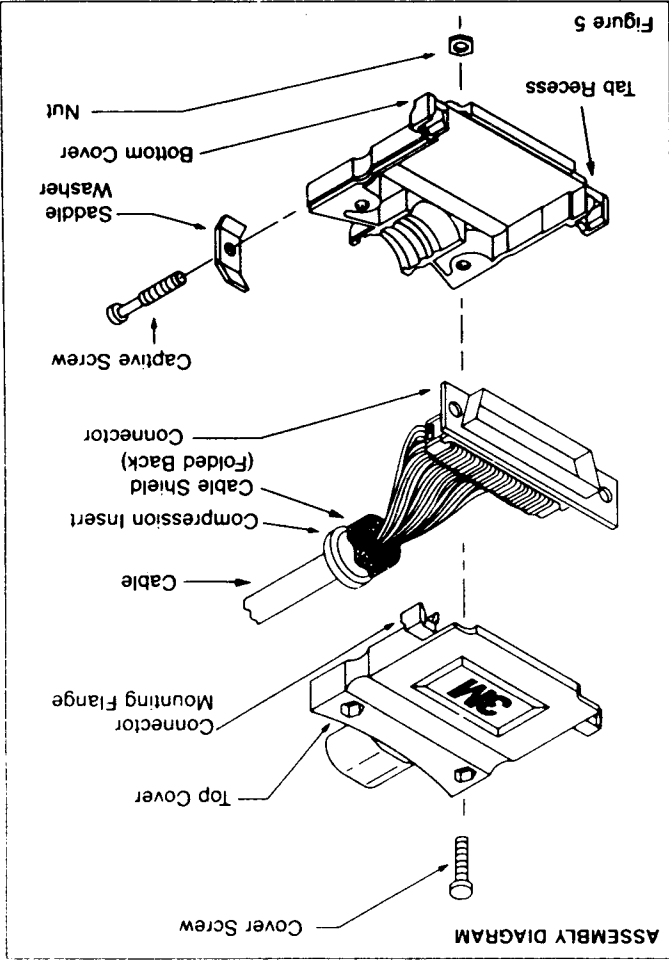

Figure 5

Important Notice to Purchaser:

All statements, technical information and recommendations contained herein are based on tests we believe to be reliable, but the accuracy or completeness thereof is not guaranteed, and the following is made in lieu of all warranties expressed or implied:

Seller's and manufacturer's only obligation shall be to replace such quantity of the product proved to be defective. Neither seller nor manufacturer shall be liable for any injury, loss or damage, direct or consequential, arising out of the use or the inability to use the product. Before using, user shall determine the suitability of the product for his intended use, and user assumes all risk and liability whatsoever in connection therewith.

No statement or recommendation not contained herein shall have any force or effect unless in an agreement signed by officers of seller and manufacturer.

Electronic Products Division/3M

Bldg 502

PO Box 2963

Austin, Texas 78769-2963

