

1/2" angular impact wrench

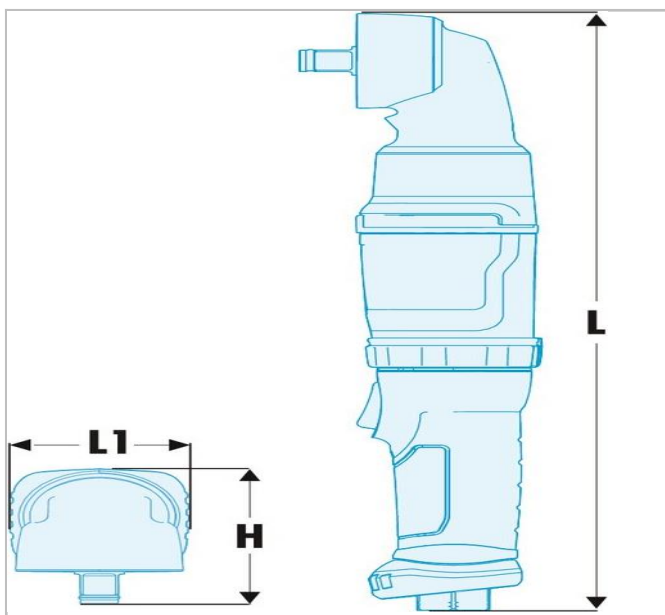

Description:

- Powerful and robust single hammer mechanism.
- Ergonomic “soft” grip insulates from the cold.
- Protection bumpers for long durability.
- Soft trigger for excellent speed control.
- Safe and fast socket locking by friction pin.



	Height H [mm]	Length L [mm]	Length L1 [mm]	Torque NM. [Nm]	Vibration Level [m/s ²]	Maximum Speed [rpm]	Weight [Kg]
NS.A1700F2	80.0	353.0	63.0	271.0	29,96 (K=14,35)	7200.0	1.8