



Auxiliary supply U_s			
Operational frequency	min	Hz	50
	max	Hz	60
Power consumption			
	Max	VA	3.5
Power dissipation Max		W	2.7
Measuring voltage inputs			
Rated voltage (U_e)	phase-phase	VAC	380...415
	phase-neutral	VAC	220...240
Operating voltage range	phase-phase	VAC	323...456
	phase-neutral	VAC	187...264
Connection method		Via CT	
Current			
IEC maximum (I_{max})		A	5
IEC minimum (I_{min})		A	0.05
IEC rated (I_{ref-Ib})		A	5
IEC start (I_{st})		mA	0.005
Transition (I_{tr})		A	0.25
Accuracy			
	Active energy		Class 0.5s (IEC/EN 62053-22)
	Reactive energy		Class 2 (IEC/EN 62053-23)
Output characteristics			
LED Pulse rate		pulse/kWh	1000
LED Pulse duration		ms	30
Insulations			
Rated insulation voltage U_i IEC/EN		V	250
Rated impulse withstand voltage U_{imp}		kV	6
Operating frequency withstand voltage		kV	4
Mechanical features			
Housing type		Polyamide	
Terminals type		Fixed	
Conductor cross section	min	mm ²	0.2
			4 for supply voltage measurement;
	Max	mm ²	2.5 for current measurement
	min	AWG	24
	Max	AWG	12

Tightening torque (Max)

Nm	0.8
lbin	7

Fixing

Din rail

Weight

g	332
---	-----

Ambient conditions

Temperature

Operating temperature

min	°C	-25
max	°C	+55

Storage temperature

min	°C	-25
max	°C	+70

Relative humidity

%	<80
---	-----

Maximum Pollution degree

2

Dimensions

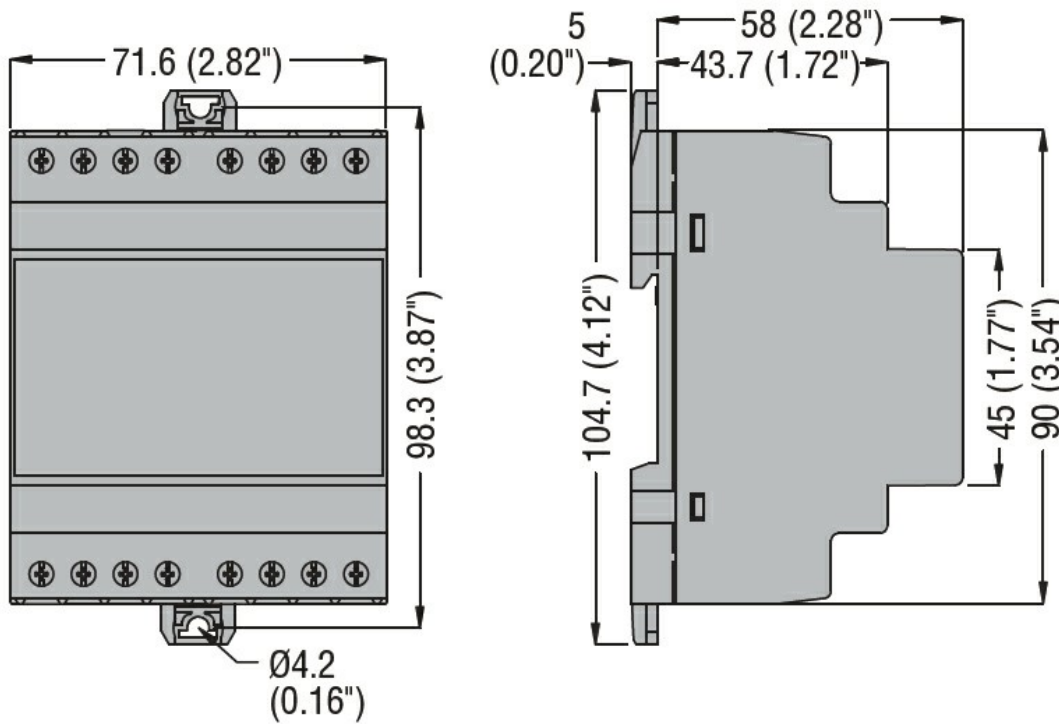

Wiring diagrams

Single-phase

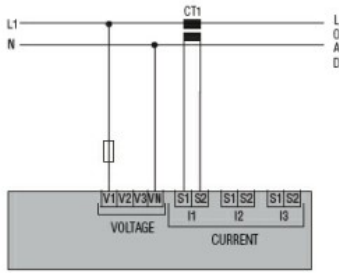

Two-phase

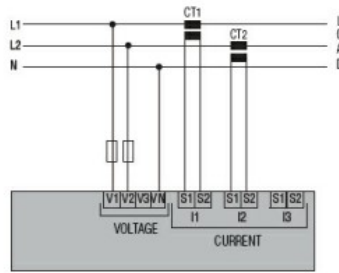

Three-phase with or without neutral

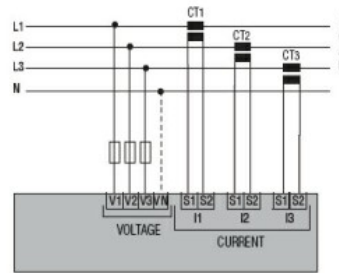

Three-phase without neutral in ARON connection

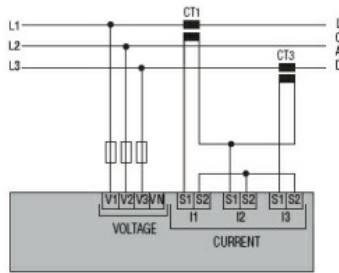
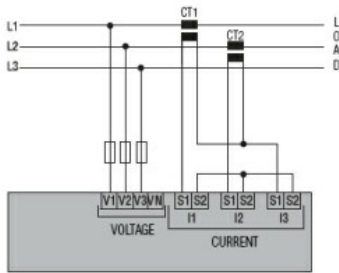

Tariff input

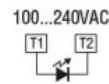

Pulse output 30VDC 50mA for DME D305 T2

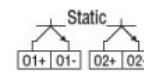

RS485 for DME D330



M-Bus for DME D332



Certifications and compliance

Compliance

- IEC/EN 50470-1
- IEC/EN 61010-1
- IEC/EN 61010-2-030

Certificates

- EAC
- RCM

ETIM classification

ETIM 8.0

EC001506 -
Kilowatt-hour
meter