



Stepper Motor Drive Boards

Data Sheet

Unipolar stepper motor drive board
(**RS stock no. 217-3611**) and
bipolar stepper motor drive board
(**RS stock no. 255-9065**)

The unipolar drive board is capable of driving any 4-phase stepper motor up to 2A, 30Vdc/phase (including the RS 7.5° motors with much improved stepping rates over the driver ic. The bipolar board is capable of driving any 4-phase stepper motor up to 3.5A, 36V/phase, the board may be used as a stand alone unit or in conjunction with external logic.

Features

- Directly compatible with any of the RS stepper motors
- Eurocard system compatible. Alternatively they may be surface mounted
- Full step and half step drive modes
- External control inputs are CMOS and open collector TTL logic compatible
- On-board power supplies for external circuit energisation
- Provision for assembling on-board oscillator (if external clock is not available), having clock pulse output, base speed, running speed and stop/run controls.

Technical specification

	Unipolar stepper motor drive board	Bipolar stepper motor drive board
Size	Eurocard 168 3 100 3 15	Eurocard 160 3 100 3 62
Mating edge connector	Standard 32 way DIN 41612 socket eg. RS stock nos. 471-503 or 467-453	High power 32 way DIN 41612 socket eg. RS stock nos. 473-149 or 473-155
Supply - board - motor	{ 15-30Vdc + 10% max. unregulated smoothed	15-24Vdc + 10% max. unregulated smoothed 15-36Vdc + 10% max. unregulated smoothed
Current consumption - - board only	60mA typ.	100mA max. 80mA typ.
- motor windings 2A/phase max.	Dependent on motor used - up to 3.5/phase max.	Dependent on motor used - up to
On-board auxiliary output	12Vdc 50mA max. regulated 5Vdc 50mA max. regulated	12Vdc 50mA max. regulated
Switching logic control inputs	Level '0' 0V } CMOS and open collector TTL compatible Level '1' 12V }	
a) Full/Half step	Level '1' full step, level '0' half step	
b) Direction	Clockwise or anticlockwise	
c) Clock step	1Hz-25kHz, 10µs minimum pulse with negative edge triggered	
d) Preset	Active level '0'. Sets motor drive to Q1 and Q3 OFF, Q2 and Q4 ON (full step mode), Q1, Q2 and Q3 OFF, Q4 ON (half step mode)	
Operating temperature range	0°C to +40°C	0°C to +40°C

Figure 1 Unipolar stepper motor drive board connections

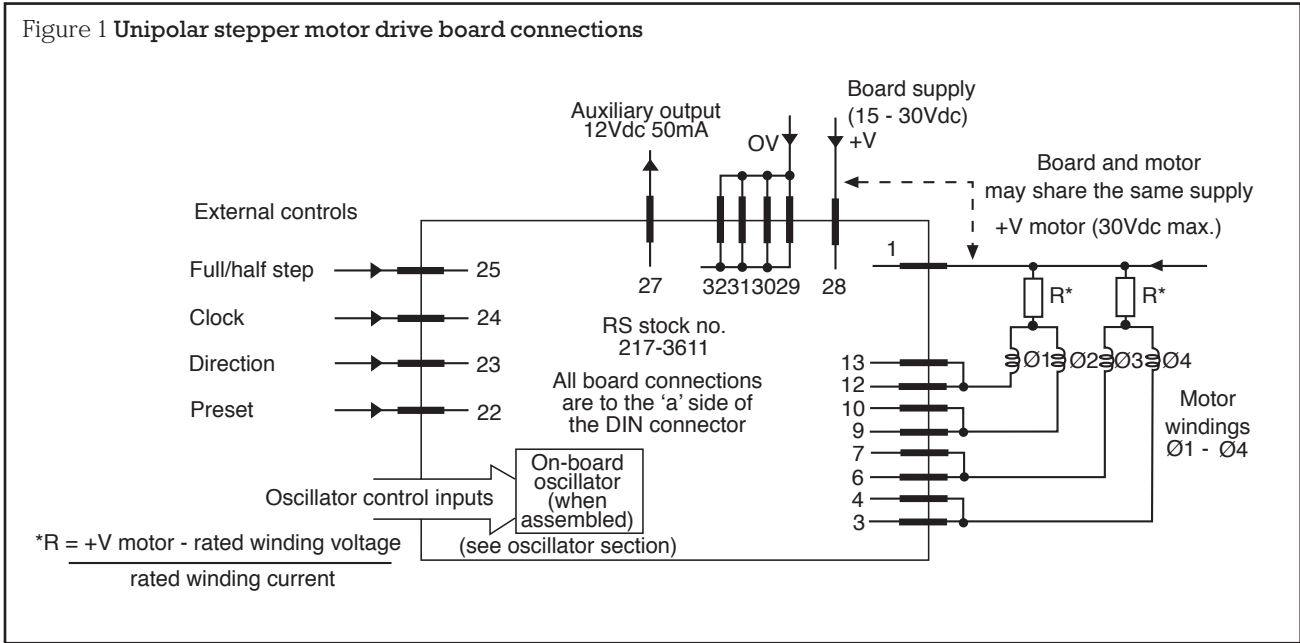
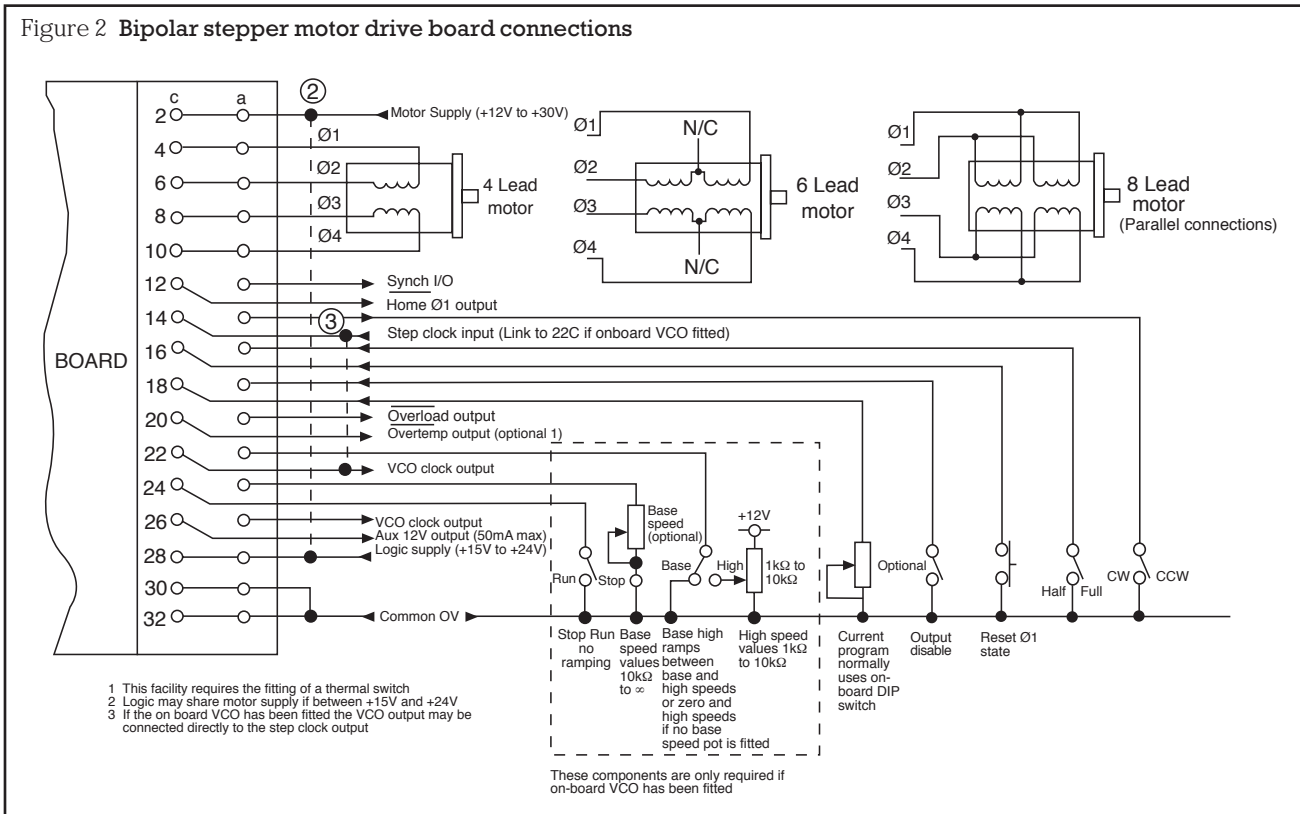

Figure 2 Bipolar stepper motor drive board connections



Maximum power dissipated through $R = (\text{rated motor current})^2 \times 3 R$. If the power dissipation is high it is advisable to arrive at the required value of R by using a network of series or parallel resistors. The use of heat sinks and higher wattage resistors may be necessary in applications where power dissipation is excessive.

Maximum current consumption (motor + board) = 2.3 (current per phase) + 60mA for unipolar board, 100mA for bipolar board. Thus ensure power supply cables used are sufficiently rated.

External control signal eg. full/half step, direction etc as well as the oscillator (if fitted) stop/run signal can be applied to the board in any of the methods of Figure 3.

Figure 3 External control input applications

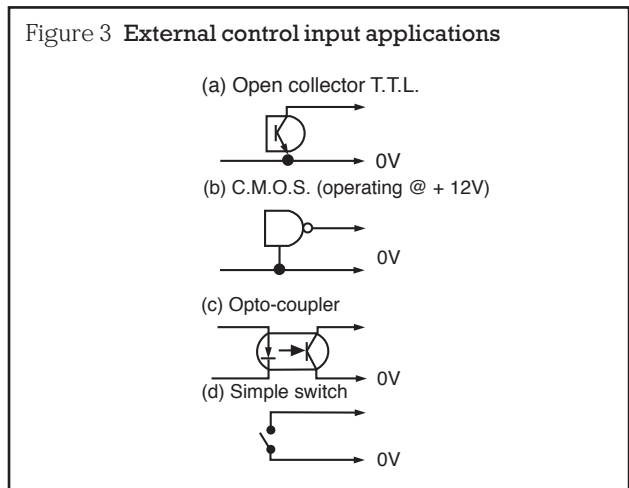

Connection to RS unipolar stepper motor board

When the windings of the RS stepper motors are assigned (01-04) as shown in Figure 4, they can be connected to the board according to Figures 1 or 2.

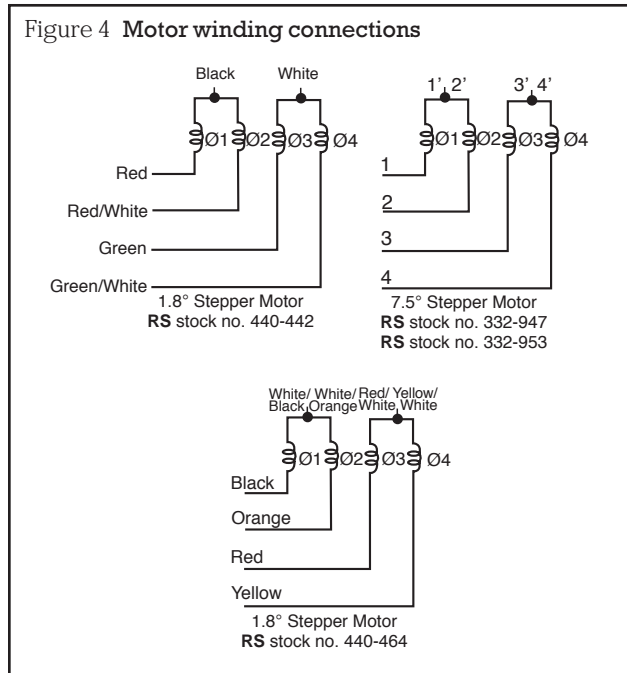

If the supply voltage is set to 24Vdc then R values for use with the RS motors are given in Table 1.

Table 1

Motor RS stock no.	Rated current (A)	Rated winding voltage (V)	R (Ω)	Power dissipation through R (W)
332-947	0.1	12	120	1.2
332-953	0.24	12	47	3
440-442	1	5	19	19
440-464	1.7	3	12.3	36

Here the 7.5° motors are driven in the L/2R mode while the 1.8° motors are driven in the L/5R and L/8R modes respectively.

Characteristics of unipolar drive board

Typical pull-out performance characteristics (under no-load conditions) for the RS motors when being driven by the drive board RS stock no. 217-3611 using a 24Vdc supply and series resistance as in Table 1 are given in Figures 5 to 8.**

** These results are typical at 20°C. If the motor temperature rises due to power dissipation in the windings and/or higher ambient temperatures the torque capability decreases (typical torque derate - 0.4% per degree rise in temperature).

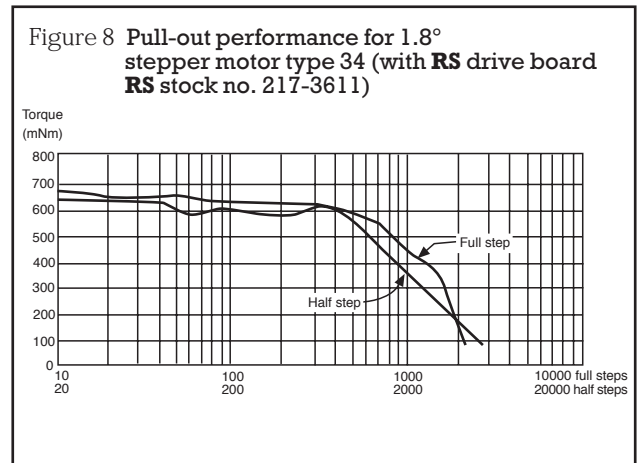
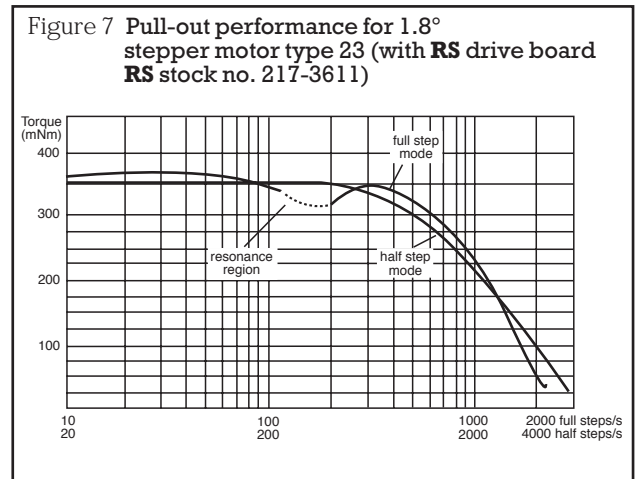
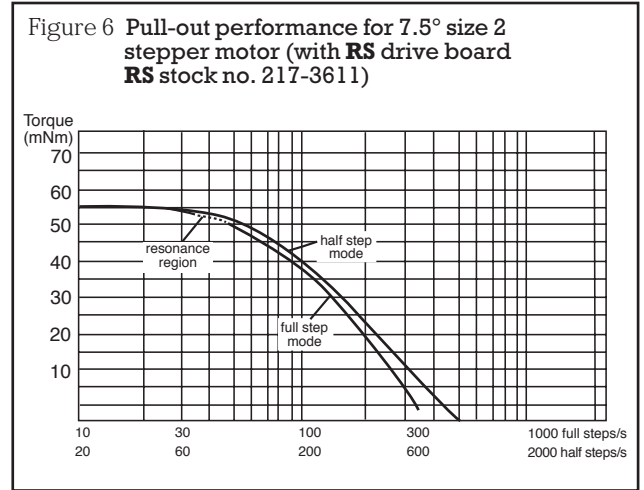
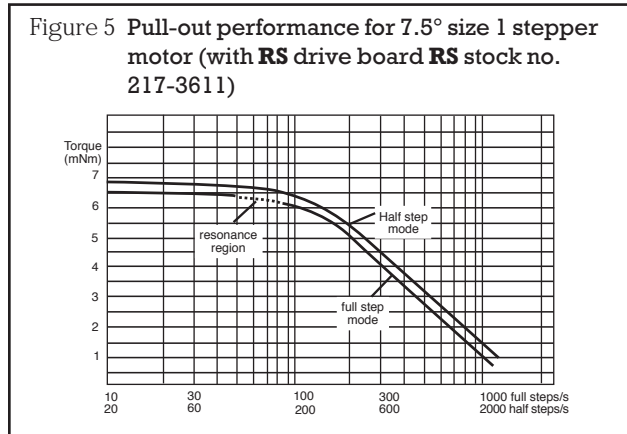

Connection to RS bipolar stepper motor board

When the windings of the RS stepper motors are assigned (Ø1-Ø4) as shown in Figure 9, they can be connected to the board according to Figure 2.

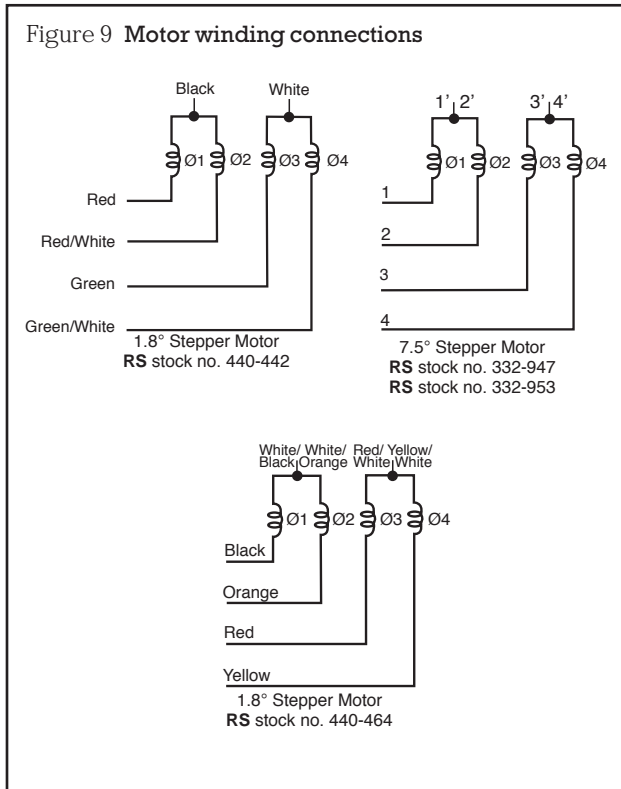

The flexibility of on-board motor current selection enables a wide range of motors to be utilised. The best high speed torque performance will be obtained by using a motor with a higher current rating than the drive card (typically 3.5A to 6A) and a low winding inductance although low speed torque may suffer. Conversely for high torque low speed operation a motor with a higher winding resistance and inductance should be used.

When using 8 lead motors with coils in parallel the motor current should be set to greater than:

$$I \text{ per phase } 3\sqrt{2}$$

When using 6 lead or 8 lead motors with coils in series the motor current should be set no greater than:

$$I \text{ per phase } 3\sqrt{2} \frac{1}{2}$$

Motors with 4 leads have a bipolar rating and can be used according to manufacturer's specification.

Nominal motor current vs. switch settings

Nominal current per phase	Switch settings			
	S1	S2	S3	S4
3.5A	ON	ON	ON	ON
3.25A	OFF	ON	ON	ON
3.0A	ON	ON	ON	OFF
2.7A	OFF	ON	ON	OFF
2.4A				
(RS stock no. 440-464)	ON	ON	OFF	OFF
2.25A	OFF	OFF	ON	ON
2A	ON	OFF	ON	OFF
1.6A	OFF	OFF	ON	OFF
1.2A	ON	OFF	OFF	OFF
0.7A				
(RS stock no. 440-442)	OFF	OFF	OFF	OFF

An external current setting resistor may also be added between pin 18C and 0V to reduce the motor current if required. This facility is particularly useful for interchangeability in multi axis systems using different motors, as all drive boards can be set at maximum and an external resistor added to dedicate that particular axis.

Another useful application for this feature is to switch in a resistor at standstill to produce a holding torque (typically 20%) and conserve power. To select the required current connect a high impedance voltmeter from pin 18C to 0V and increase/decrease the external resistor until the correct voltage is achieved, where the nominal scaling factor is

$$V = I \text{ per phase } 3 \cdot 0.47$$

Installation - general notes

1. SERIOUS DAMAGE **WILL** OCCUR if a motor lead becomes disconnected whilst the drive is energised.
2. The drive board should always be mounted such that the heatsink fins are vertical ie. board on edge, and adequate clearance be given top and bottom ie. 25mm minimum. When rack mounting the board there should be at least a 15mm clearance between the heatsink and an adjacent board.
3. When using the drive at high ambient temperatures or at slow speeds/standstill at maximum current and voltage it will prove advantageous to force cool the heatsink.
4. Motor and power supply connections should be made in at least 24/0.2mm wire due to the high peak currents flowing, all other wiring can be 7/0.2mm.
5. No damage will occur, but the Full step/Half step input (pin 16a) should be connected as required before the drive is energised.

Characteristics of bipolar drive board

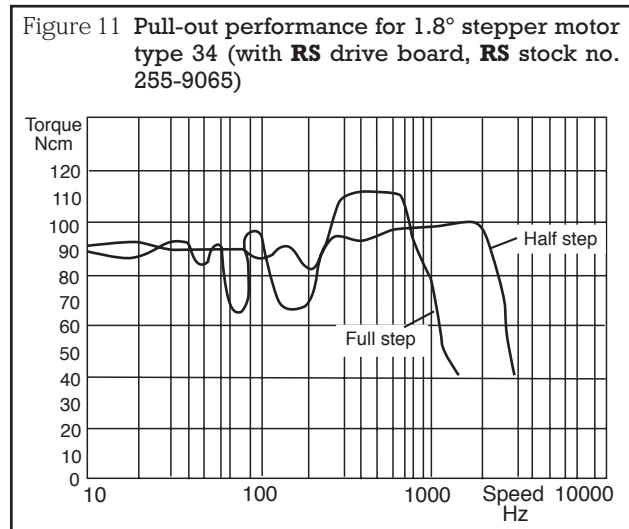
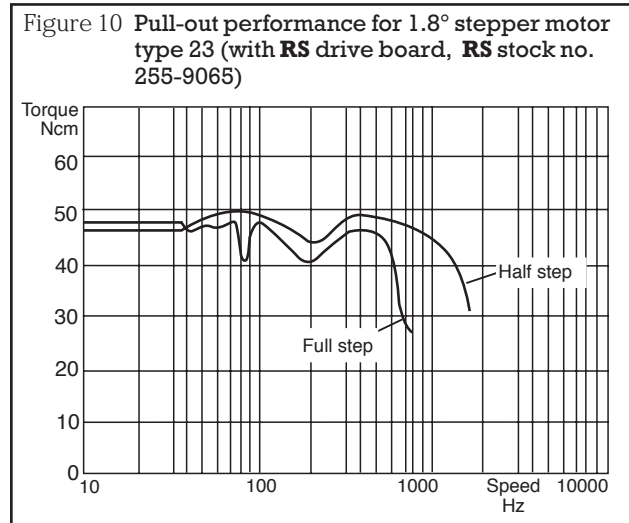

On-board oscillator assembly

If an external clock source is not available an on-board oscillator can be assembled simply by soldering into place the required components listed below - see current RS Catalogue.

Note: That the oscillator clock output must be externally wired to the clock input - pin 14c.

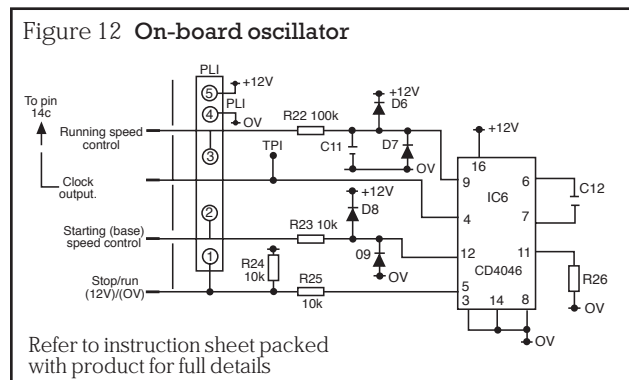

R22 (R14)	100kΩ resistor	RS stock no. 131-491	1 off
R23, 24, 25 (R15, 16, 17)	10kΩ resistor	RS stock no. 131-378	3 off
D6, 7, 8, 9	Signal diode	RS stock no. 271-606	4 off
(D13, 14, 15, 16)	CMOS IC	RS stock no. 306-645	1 off
R26 (R13), C11 & C12	(Value depends on application)		1 off each

Circuit references in brackets refer to bipolar board.

If oscillator remote controls are required (eg. front panel controls) then plug PL1 (5-way inter-PCB RS stock no. 467-576) can be added together with mating cable shell RS stock no. 467-627 and crimp terminals.

Starting (base) and running speed control

The on-board oscillator can be arranged to start at a fixed frequency (thus a fixed motor speed) and then ramp up to a final value (the running motor speed). This facility is available to start the motor within its pull-in performance region and then accelerate the motor to its final speed such that it can operate within the pull-out mode. On switch-off the motor decelerates automatically.

Three parameters need to be determined for any application:

1. The starting speed; this should be below pull-in speed for the motor (including any additional load).
2. The running (final) speed; this should be within the pull-out capability of the motor (including any additional load).
3. The acceleration and deceleration rate between starting and running speeds; this is limited by the motor capability to accelerate through its own, plus any load, inertia.

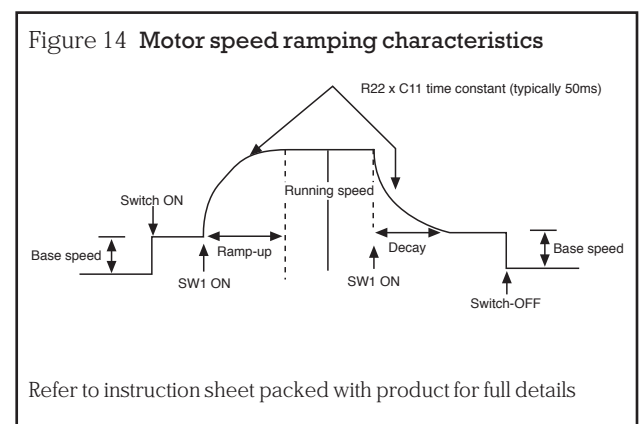
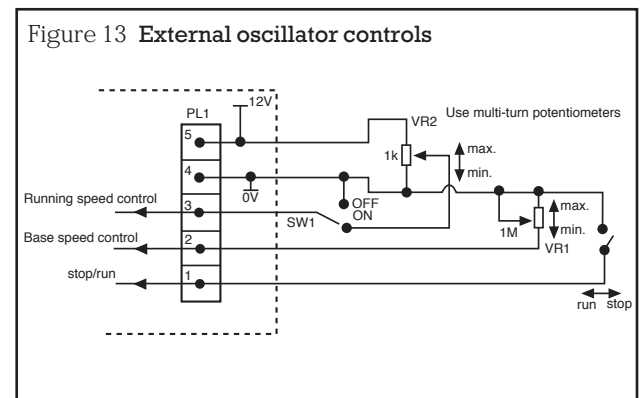

Note: Oscillator frequency corresponds directly to motor speed in steps/s or half step/s depending on the motor drive mode.

For a 1.8° stepper motor

$$\text{speed in revs/min} = \frac{60}{200} \times \text{speed in step/s}$$

$$\text{or} \quad \frac{60}{400} \times \text{speed in half step/s}$$

Oscillator frequency setting

Recommended component values (refer to Figures 18 and 19)

- VR1 0 - 1mΩ use multiturn
- VR2 1kΩ potentiometers
- R26 (R13) 10kΩ - 1MΩ
- C12 greater than 100pF

Determine the base frequency and maximum running frequency. Using Figure 25 choose a value for C12 and VR1. Calculate the ratio maximum running frequency/ base frequency to determine the ratio of

$$\frac{VR1 + R23 \text{ (fixed at } 10k\Omega\text{)}}{R26}$$

and thus using Figure 16 establish the required value for R26 (R13).

Figure 15 **Base frequency variations with timing capacitor C12**

Base frequency (R26 = ∞ VR2 = min.)

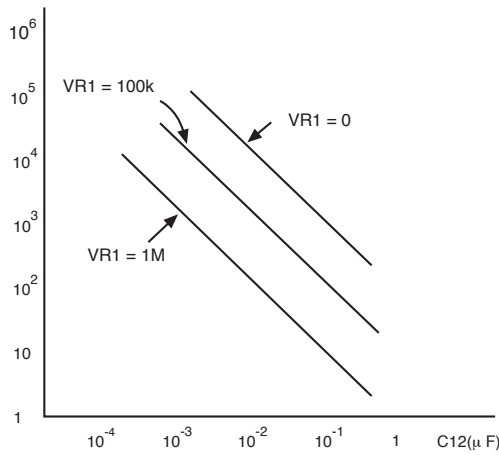

Figure 16 **Resistor value as a function of maximum frequency/base frequency**

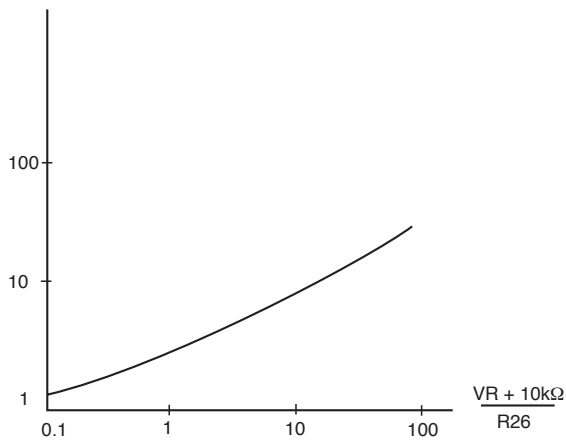
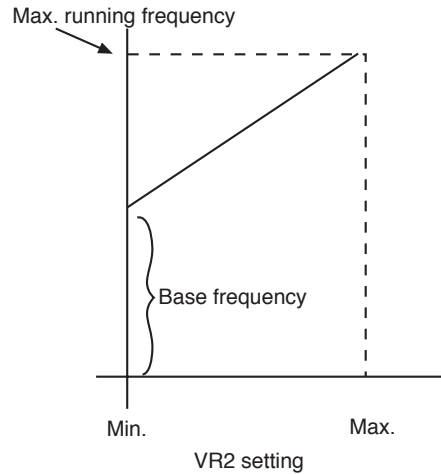

Figure 17 **Oscillator frequency range**



Once all component values are established and assembled the oscillator frequency range is as shown in Figure 17. If SW1 is OFF the oscillator runs at base frequency. When SW1 is ON the oscillator builds up at a rate (at a rate depending on R22 x C11 time constant) to a frequency determined by VR2 setting.

RS Components shall not be liable for any liability or loss of any nature (howsoever caused and whether or not due to RS Components' negligence) which may result from the use of any information provided in RS technical literature.