

RS Information Sheet - 06B0410 (LB008)

Lever Hoist KITO LB Series

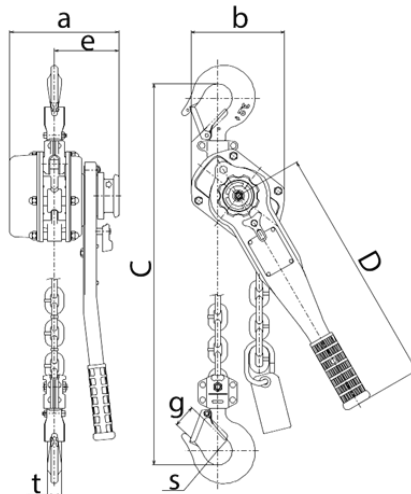

General:

The standard LB Lever Hoist is supplied with a freewheel safeguard and the bottom hook is riveted in four places. The lever hoists are built with premium grade components for long life in demanding industrial applications. Its double-reduction gearing reduce size and weight and requires minimum power to operate. Sealed gears and brake are protected against damage from dust and water. Open load sheave allows easy inspection and cleaning without dismantling the unit.

Material: High impact steel housing, nickel-plated load chain grade V (G100) according to EN 818-7.

Marking: WLL, code and CE marking.

Safety factor: 4:1.

Finish: Painted.

Code	WLL	Hand pull to lift full load	Load chain Ø	Lifting height	Chain falls	a	b	C	D	e	g	s	t	Weight*
	tons	daN	mm	m		mm							kg	
LB008	0,8	28,4	5,6 x 15,7	1,5	1	144	119	280	245	97	23,5	35,5	14,0	5,7
LB010	1,0	35,3	5,6 x 15,7	1,5	1	144	119	300	245	97	29,0	42,5	15,0	5,9
LB016	1,6	33,3	7,1 x 19,9	1,5	1	159	126	335	265	100	32,0	42,5	19,0	8,0
LB025	2,5	36,3	8,8 x 24,6	1,5	1	173	150	375	265	102	36,5	47,0	21,0	11,2
LB032	3,2	36,3	10,0 x 28,0	1,5	1	190	159	395	415	112	39,0	50,0	24,5	15,0
LB063	6,3	37,2	10,0 x 28,0	1,5	2	190	217	540	415	112	50,0	60,0	34,0	26,0
LB090	9,0	38,2	10,0 x 28,0	1,5	3	190	304	680	415	112	72,5	85,0	41,5	40,0