

EFC8811R

Advance Information Power MOSFET 12V, 3.2mΩ, 27A, Dual N-Channel

This Power MOSFET features a low on-state resistance. This device is suitable for applications such as power switches of portable machines. Best suited for single cell lithium-ion battery applications.

Features

- 2.5V drive
- 2kV ESD HBM
- Common-Drain Type
- ESD Diode-Protected Gate
- Pb-Free, Halogen Free and RoHS compliance

Applications

- Single Cell Lithium-ion Battery Charging and Discharging Switch

SPECIFICATIONS

ABSOLUTE MAXIMUM RATINGS at Ta = 25°C (Note 1)

Parameter	Symbol	Value	Unit
Source to Source Voltage	V _{SS}	12	V
Gate to Source Voltage	V _{GSS}	±8	V
Source Current (DC)	I _S	27	A
Source Current (Pulse) PW≤100μs, duty cycle≤1%	I _{SP}	100	A
Total Dissipation When mounted on ceramic substrate (5000mm ² × 0.8mm)	P _T	2.5	W
Junction Temperature	T _J	150	°C
Storage Temperature	T _{stg}	-55 to +150	°C

Note 1 : Stresses exceeding those listed in the Maximum Ratings table may damage the device. If any of these limits are exceeded, device functionality should not be assumed, damage may occur and reliability may be affected.

THERMAL RESISTANCE RATINGS

Parameter	Symbol	Value	Unit
Junction to Ambient When mounted on ceramic substrate (5000mm ² × 0.8mm)	R _{θJA}	50	°C/W



ON Semiconductor®

www.onsemi.com

V _{SS}	R _{SS(on)} Max	I _S Max
12V	3.2mΩ@ 4.5V	27A
	3.2mΩ@ 4.0V	
	3.2mΩ@ 3.8V	
	4.4mΩ@ 3.1V	
	6.3mΩ@ 2.5V	

ELECTRICAL CONNECTION N-Channel

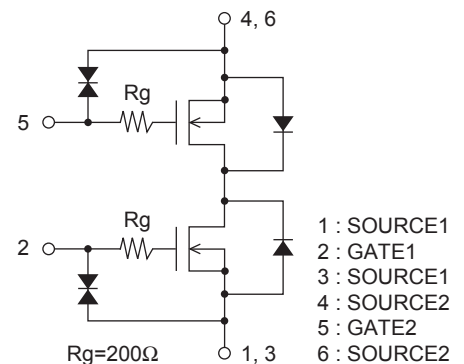

CSP6, 1.77x3.54 /
EFCP3517-6DGH-020

MARKING



ORDERING INFORMATION

See detailed ordering and shipping information on page 6 of this data sheet.

This document contains information on a new product. Specifications and information herein are subject to change without notice.

EFC8811R

ELECTRICAL CHARACTERISTICS at Ta = 25°C (Note 2)

Parameter	Symbol	Conditions	Value			Unit
			min	typ	max	
Source to Source Breakdown Voltage	V(BR)SSS	I _S =1mA, V _{GS} =0V Test Circuit 1	12			V
Zero-Gate Voltage Source Current	I _{SSS}	V _{SS} =10V, V _{GS} =0V Test Circuit 1			1	μA
Gate to Source Leakage Current	I _{GSS}	V _{GS} =±8V, V _{SS} =0V Test Circuit 2			±1	μA
Gate Threshold Voltage	V _{GS(th)}	V _{SS} =6V, I _S =1mA Test Circuit 3	0.5		1.3	V
Forward Transconductance	g _{FS}	V _{SS} =6V, I _S =3A Test Circuit 4		19		S
Static Source to Source On-State Resistance	R _{SS(on)1}	I _S =5A, V _{GS} =4.5V Test Circuit 5	1.8	2.3	3.2	mΩ
	R _{SS(on)2}	I _S =5A, V _{GS} =4.0V Test Circuit 5	1.9	2.4	3.2	mΩ
	R _{SS(on)3}	I _S =5A, V _{GS} =3.8V Test Circuit 5	2.0	2.6	3.2	mΩ
	R _{SS(on)4}	I _S =5A, V _{GS} =3.1V Test Circuit 5	2.1	3.3	4.4	mΩ
	R _{SS(on)5}	I _S =5A, V _{GS} =2.5V Test Circuit 5	2.7	4.0	6.3	mΩ
Turn-ON Delay Time	t _{d(on)}	V _{SS} =6V, V _{GS} =4.5V, I _S =3A Test Circuit 6		80		ns
Rise Time	t _r			570		ns
Turn-OFF Delay Time	t _{d(off)}			38,000		ns
Fall Time	t _f			17,700		ns
Total Gate Charge	Q _g		V _{SS} =6V, V _{GS} =4.5V, I _S =27A Test Circuit 7		100	
Forward Source to Source Voltage	V _{F(S-S)}	I _S =3A, V _{GS} =0V Test Circuit 8		0.75	1.2	V

Note 2 : Product parametric performance is indicated in the Electrical Characteristics for the listed test conditions, unless otherwise noted. Product performance may not be indicated by the Electrical Characteristics if operated under different conditions.

Test circuits are example of measuring FET1 side

Test Circuit 1
V_{SSS} / I_{SSS}

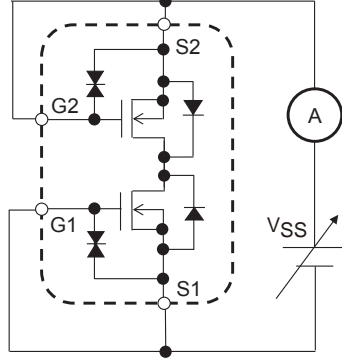

Test Circuit 2
I_{GSS}

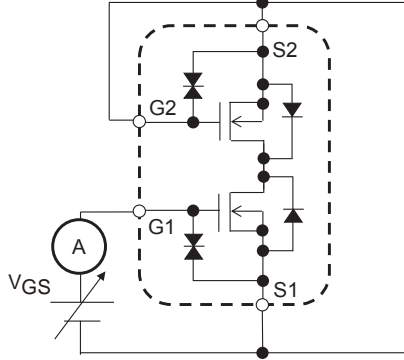

When FET1 is measured, Gate and Source of FET2 are short-circuited.

Test Circuit 3
V_{GS(th)}

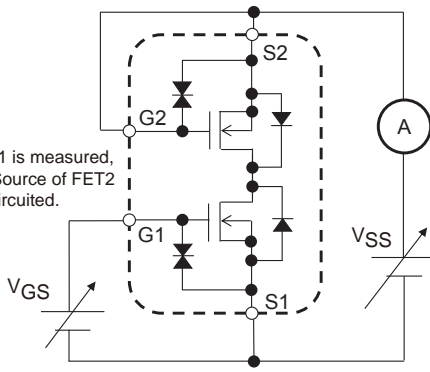

When FET1 is measured, Gate and Source of FET2 are short-circuited.

Test Circuit 4
g_{FS}

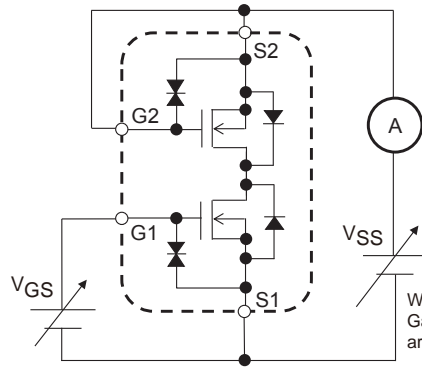

When FET1 is measured, Gate and Source of FET2 are short-circuited.

Test Circuit 5
R_{SS(on)}

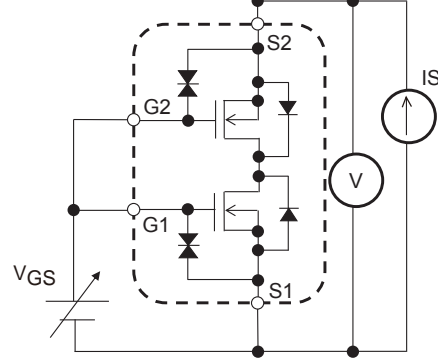

Test Circuit 6
t_{d(on)}, t_r, t_{d(off)}, t_f

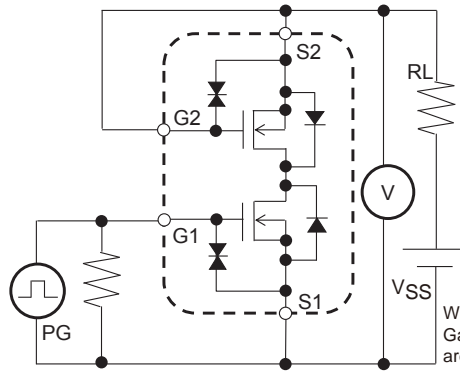

When FET1 is measured, Gate and Source of FET2 are short-circuited.

Test Circuit 7
Q_g

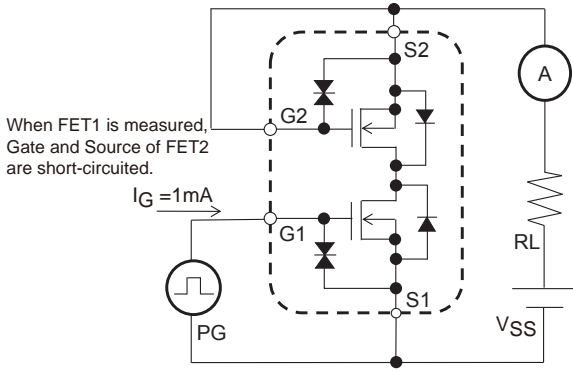

When FET1 is measured, Gate and Source of FET2 are short-circuited.

I_G = 1mA

Test Circuit 8
V_{F(S-S)}

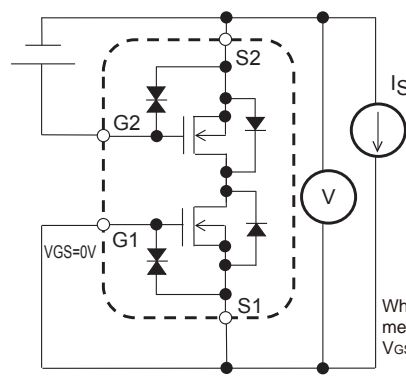

When FET1 is measured, +4.5V is added to V_{GS} of FET2.

When FET2 is measured, the position of FET1 and FET2 is switched.

EFC8811R

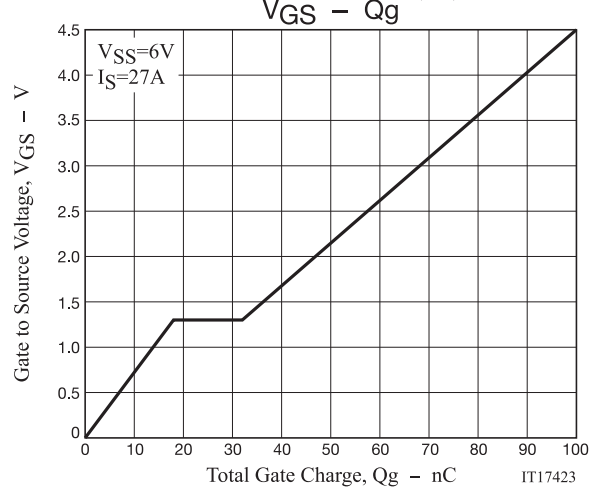
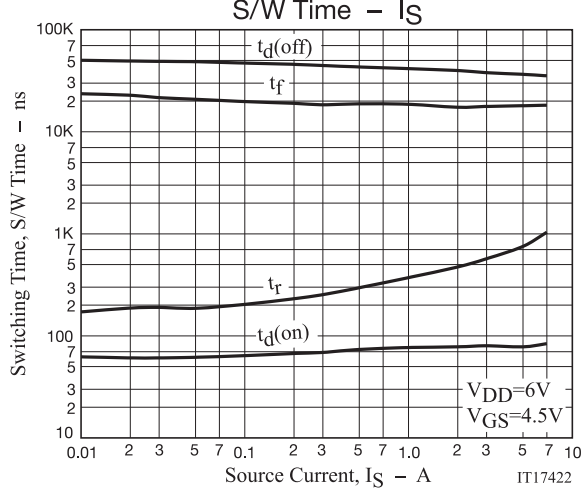
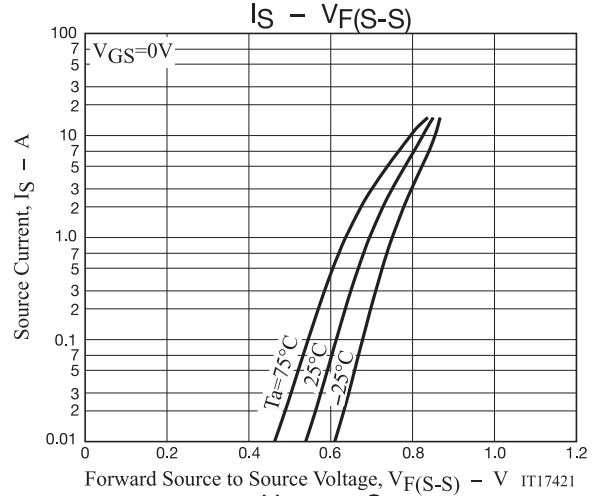
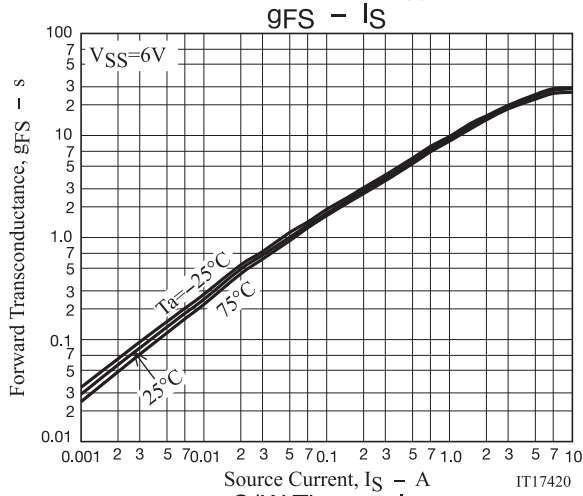
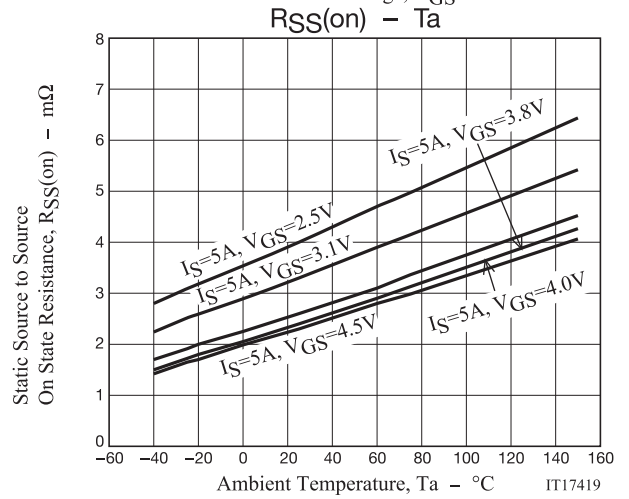
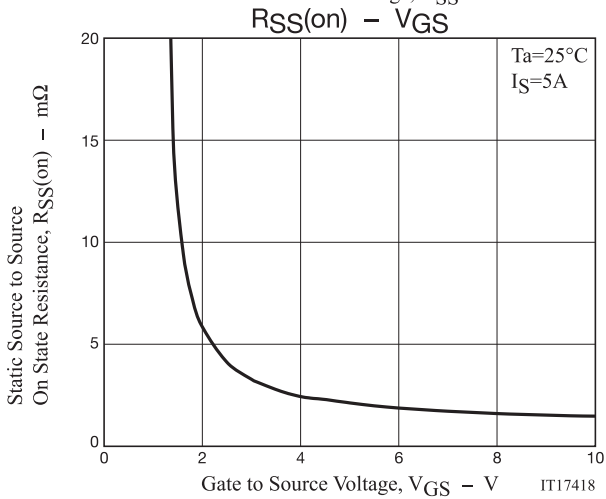
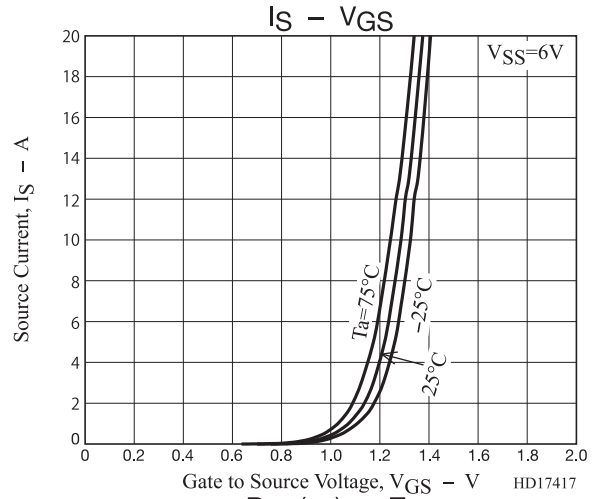
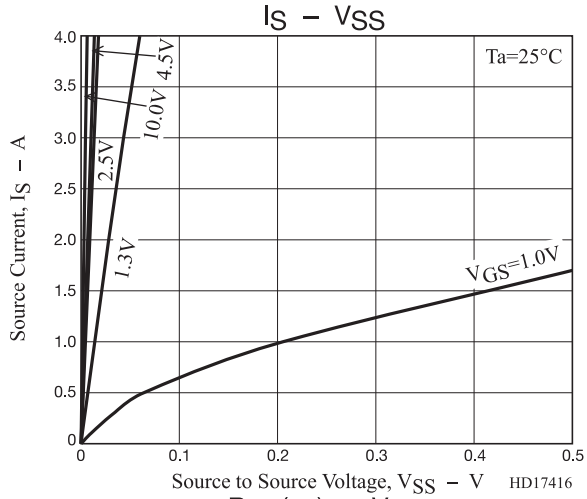

EFC8811R

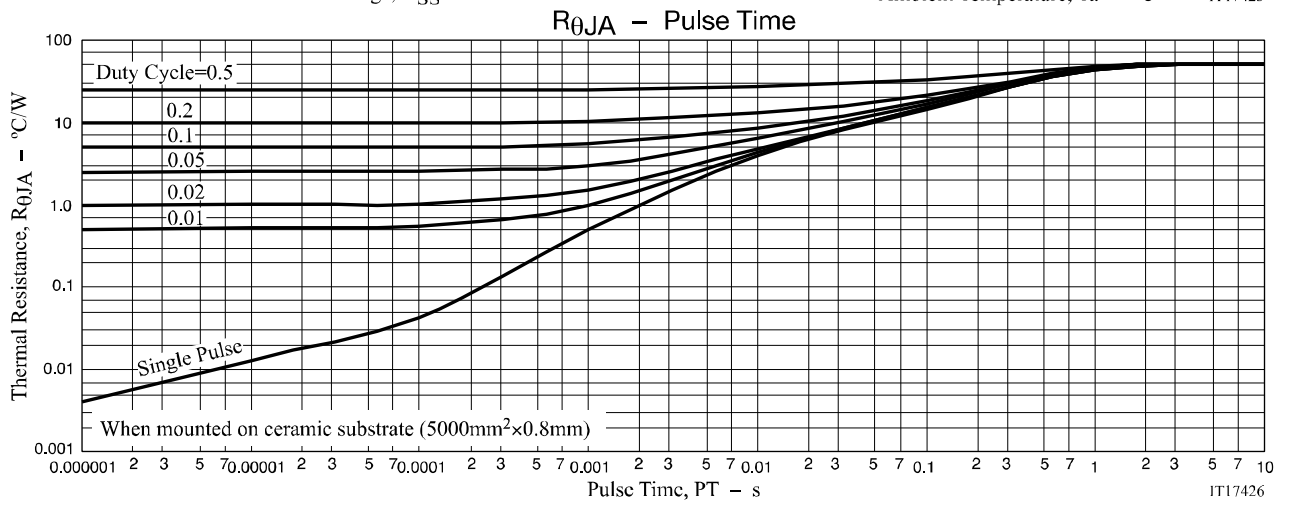
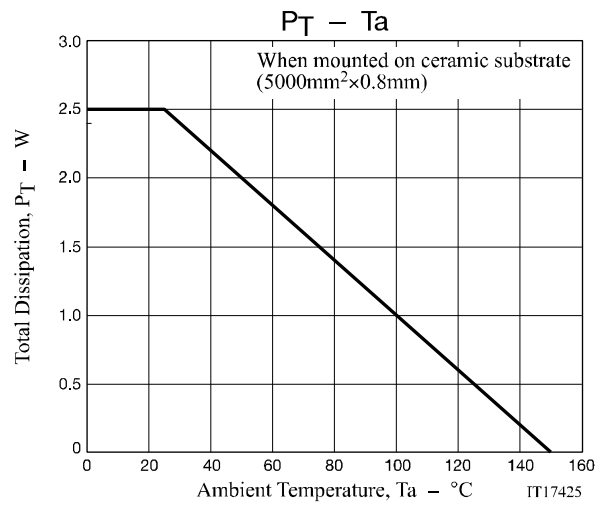
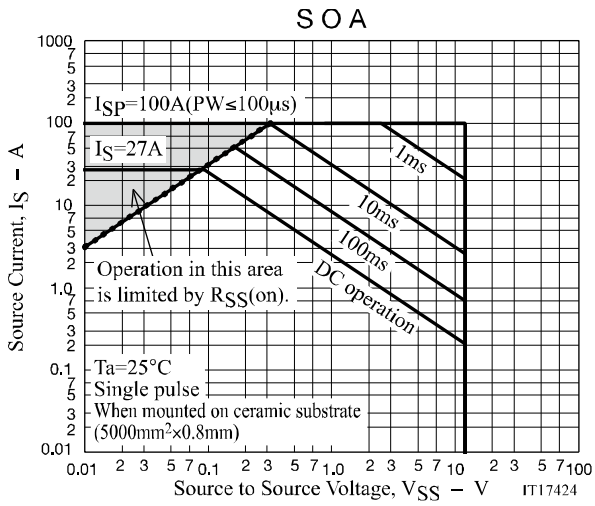

EFC8811R

PACKAGE DIMENSIONS

unit : mm

CSP6, 1.77x3.54 / EFCP3517-6DGH-020

CASE 568AL

ISSUE O

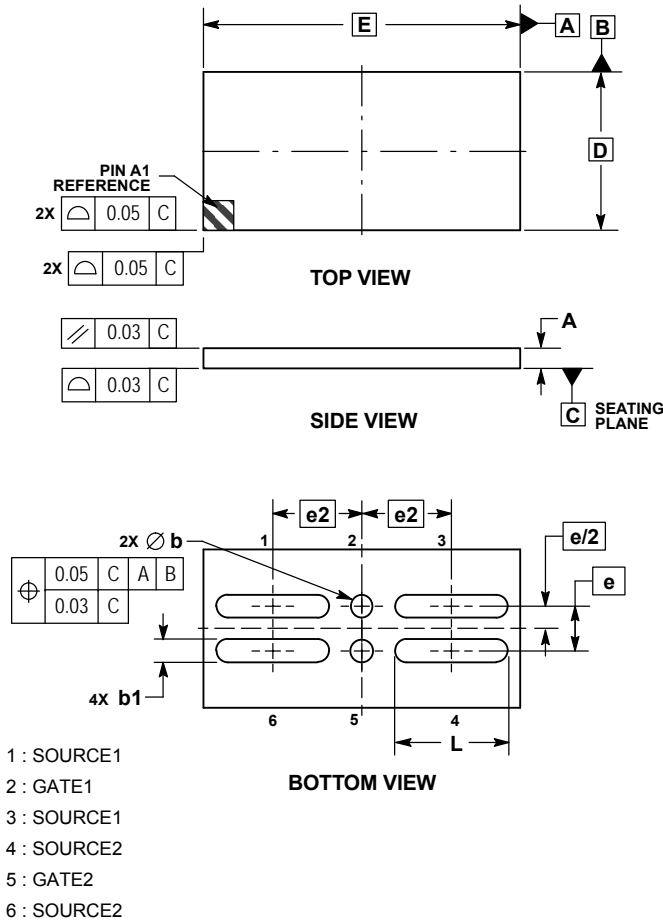

- NOTES:
1. DIMENSIONING AND TOLERANCING PER ASME Y14.5M, 1994.
 2. CONTROLLING DIMENSION: MILLIMETERS.

DIM	MILLIMETERS	
	MIN	MAX
A	---	0.22
b	0.22	0.28
b1	0.22	0.28
D	1.77 BSC	
E	3.54 BSC	
e	0.50 BSC	
e2	1.00 BSC	
L	1.22	1.28

RECOMMENDED SOLDERING FOOTPRINT*

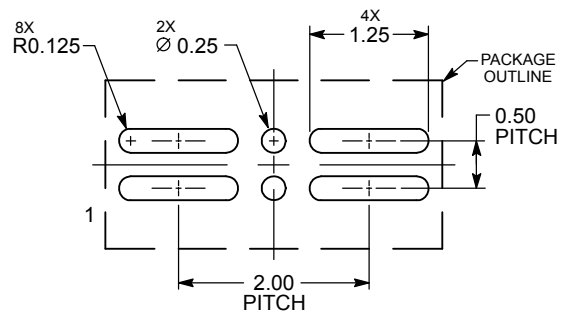

*For additional information on our Pb-Free strategy and soldering details, please download the ON Semiconductor Soldering and Mounting Techniques Reference Manual, SOLDERRM/D.

ORDERING INFORMATION

Device	Marking	Package	Shipping (Qty / Packing)
EFC8811R-TF	ML	CSP6, 1.77x3.54 / EFCP3517-6DGH-020 (Pb-Free / Halogen Free)	5,000 / Tape & Reel

† For information on tape and reel specifications, including part orientation and tape sizes, please refer to our Tape and Reel Packaging Specifications Brochure, BRD8011/D. http://www.onsemi.com/pub_link/Collateral/BRD8011-D.PDF

Note on usage : Since the EFC8811R is a MOSFET product, please avoid using this device in the vicinity of highly charged objects. Please contact us for use except the designated application.

ON Semiconductor and the ON logo are registered trademarks of Semiconductor Components Industries, LLC (SCILLC) or its subsidiaries in the United States and/or other countries. SCILLC owns the rights to a number of patents, trademarks, copyrights, trade secrets, and other intellectual property. A listing of SCILLC's product/patent coverage may be accessed at www.onsemi.com/site/pdf/Patent-Marking.pdf. SCILLC reserves the right to make changes without further notice to any products herein. SCILLC makes no warranty, representation or guarantee regarding the suitability of its products for any particular purpose, nor does SCILLC assume any liability arising out of the application or use of any product or circuit, and specifically disclaims any and all liability, including without limitation special, consequential or incidental damages. "Typical" parameters which may be provided in SCILLC data sheets and/or specifications can and do vary in different applications and actual performance may vary over time. All operating parameters, including "Typicals" must be validated for each customer application by customer's technical experts. SCILLC does not convey any license under its patent rights nor the rights of others. SCILLC products are not designed, intended, or authorized for use as components in systems intended for surgical implant into the body, or other applications intended to support or sustain life, or for any other application in which the failure of the SCILLC product could create a situation where personal injury or death may occur. Should Buyer purchase or use SCILLC products for any such unintended or unauthorized application, Buyer shall indemnify and hold SCILLC and its officers, employees, subsidiaries, affiliates, and distributors harmless against all claims, costs, damages, and expenses, and reasonable attorney fees arising out of, directly or indirectly, any claim of personal injury or death associated with such unintended or unauthorized use, even if such claim alleges that SCILLC was negligent regarding the design or manufacture of the part. SCILLC is an Equal Opportunity/Affirmative Action Employer. This literature is subject to all applicable copyright laws and is not for resale in any manner.