

M.543 | Bridge handles

Technopolymer



STANDARD EXECUTIONS

- **M.543:** glass-fibre reinforced polyamide based (PA) technopolymer, black or orange colour, matte finish. Brass boss, threaded blind hole.
- **M.543-N:** glass-fibre reinforced polypropylene based (PP) technopolymer, black colour, matte finish. Brass boss, threaded blind hole.
- **M.543-p:** glass-fibre reinforced polyamide based (PA) technopolymer, black or orange colour, matte finish. Zinc-plated steel threaded stud, chamfered flat end according to UNI 947: ISO 4753 (see Technical data on page A-10).

TECHNICAL DATA

Tensile stress and impact strength: F1, F2, L1 and L2 values reported in the table are the result of breaking tests carried out with the appropriate dynamometric equipment under the test conditions shown in the figure with ambient temperature.

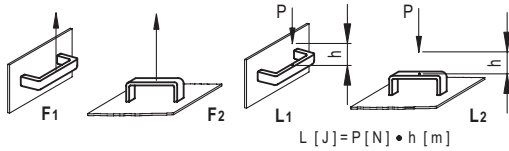

ELESA Original design

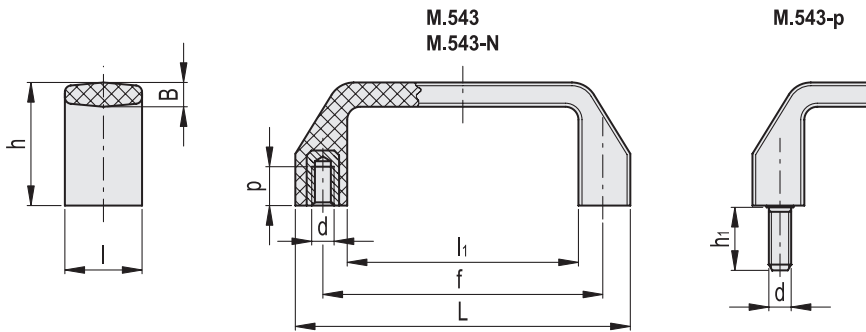

* Complete with colour index, example: 37284 M.543/110 B-M6-C2



M.543

Code C9	Code C2	Description	L	f	d6H	h	B	l	l1	p	F1 [N]	F2 [N]	L1 [J]	L2 [J]	⚖️
37283	37284	M.543/110 B-M6-*	107	93.5±0.5	M6	36	5.5	21	79	10	2000	1800	10	6	36
37287	37289	M.543/120 B-M5-*	120	105±0.5	M5	37	6.5	23	90	10	2000	1800	10	7	40
37288	37290	M.543/120 B-M6-*	120	105±0.5	M6	37	6.5	23	90	10	2000	1800	10	7	38
37285	37286	M.543/140 B-M6-*	134	117±0.5	M6	38	7	25	102	12	3000	1600	12	9	56
37291	37292	M.543/140 B-M8-*	134	117±0.5	M8	38	7	25	102	13	3000	1600	12	9	52
37296	37297	M.543/150 B-M8-*	150	132±0.5	M8	45	7.5	26	116	13	2000	1800	18	16	59
37381	37382	M.543/200 B-M8-*	200	179±1	M8	51	8.5	28	160	13	3000	2300	24	30	93
37383	37384	M.543/200 B-M10-*	200	179±1	M10	51	8.5	28	160	13	3200	2500	24	30	88

M.543-N

Code	Description	L	f	d6H	h	B	l	l1	p	F1 [N]	F2 [N]	L1 [J]	L2 [J]	⚖️
37280	M.543/140 N-B-M6	134	117±0.5	M6	38	7	25	102	12	1900	950	9	4	47

M.543-p

Code C9	Code C2	Description	L	f	d6g	h	h1	B	l	l1	F1 [N]	F2 [N]	L1 [J]	L2 [J]	⚖️
37293	37294	M.543/140 p-M6x16-*	134	117±0.5	M6	38	16	7	25	102	2200	1400	11	9	56
37387	37388	M.543/200 p-M8x16-*	200	179±1	M8	51	16	8.5	28	160	3400	2600	24	30	109