

DATA SHEET

Introduction Surface-mount ceramic multilayer capacitors

Product specification
Supersedes data of 11th February 1999

2001 May 30 Rev.7

Surface-mount ceramic multilayer capacitors

Introduction

GENERAL DATA

Ceramic capacitors are widely used in electronic circuitry for coupling, decoupling and in filters. These different functions require specific capacitor properties.

Ceramic capacitors can be divided into two classes:

- Class 1

In these capacitors dielectric materials are used which have a very high specific resistance, very good Q and linear temperature dependence (ϵ_r from 6 up to 550). They are used in such applications as oscillators and filters where low losses, capacitance drift compensation and high stability are required.

- Class 2

These capacitors have higher losses and have non-linear characteristics ($\epsilon_r > 250$). They are used for coupling and decoupling.

CONSTRUCTION

The capacitance of a ceramic capacitor depends on the area of the electrodes (A), the thickness of the ceramic dielectric (t) and the dielectric constant of the ceramic material (ϵ_r); and on the number of dielectric layers (n) with multilayer ceramic capacitors:

$$C = \epsilon_r \times \epsilon_0 \times \frac{A}{t} \times n$$

The rated voltage is dependent on the dielectric strength, which is mainly governed by the thickness of the dielectric layer and the ceramic structure. For this reason a reduction of the layer thickness is limited.

Figure 2 shows the construction of a multilayer capacitor.

MANUFACTURING OF CERAMIC CAPACITORS

The raw materials are finely milled and carefully mixed. Thereafter the powders are calcined at temperatures between 1100 and 1300 °C to achieve the required chemical composition. The resultant mass is reground and dopes and/or sintering means are added.

The finely ground material is mixed with a solvent and binding matter. Thin sheets are obtained by casting or rolling.

For multilayer capacitors electrode material is printed on the sheets and after stacking and pressing of the sheets cofired with the ceramic compact at temperatures between 1000 and 1400 °C.

The totally enclosed electrodes of a multilayer capacitor guarantee good life test behaviour as well.

EQUIVALENT CIRCUIT FOR CERAMIC CAPACITORS

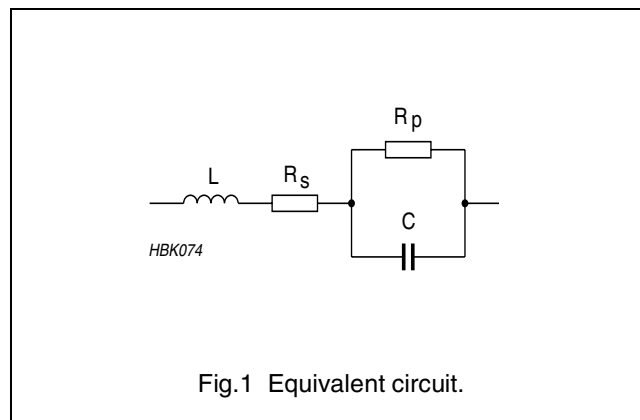

Fig.1 Equivalent circuit.

Definition of symbols; see Fig.1

SYMBOL	DESCRIPTION
C	Capacitance between the two electrodes, plus the stray capacitance at the edges and between the leads.
R _p	Resistance of insulation and dielectric. Generally R _p is very high, and of decreasing importance with increasing frequency. R _p also represents the polarization losses of the material in an alternating electric field.
R _s	Losses in the leads, the electrodes and the contacts. Up to several hundreds of MHz the current penetration depth is greater than the conductor thickness so that no skin-effect occurs. For ceramic capacitors R _s is extremely low.
L	Inductance of the leads and the internal inductance of the capacitor; the latter, however, is almost negligible. The inductance is only important in high frequency applications, since the capacitor will act as an inductance when the frequency is higher than its resonance frequency.

Surface-mount ceramic multilayer capacitors

Introduction

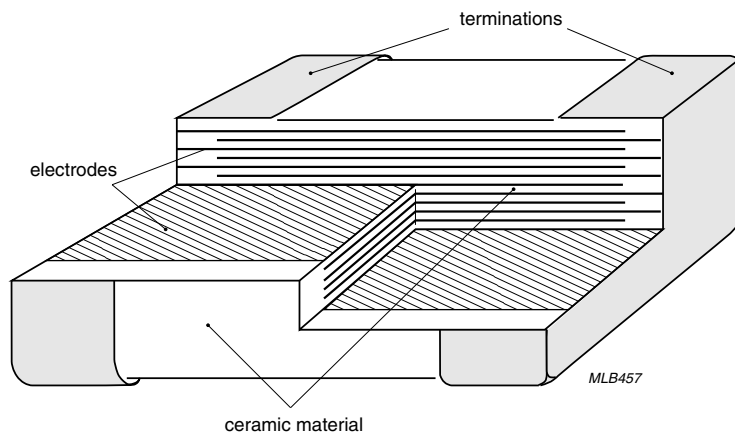

Fig.2 Cross-section of a multilayer capacitor.

Surface-mount ceramic multilayer capacitors

Introduction

TANGENT OF THE LOSS ANGLE

The losses of a capacitor are expressed in terms of $\tan \delta$ which is the relationship between the resistive and reactive parts of the impedance, specified as follows:

$$\tan \delta = \frac{|R|}{|X|} = \frac{R_p + R_s \{1 + (\omega CR_p)^2\}}{(\omega CR_p)^2 - \omega L \{1 + (\omega CR_p)^2\}}$$

From this formula, $\tan \delta$ can be derived for different frequency ranges as shown in Fig.3.

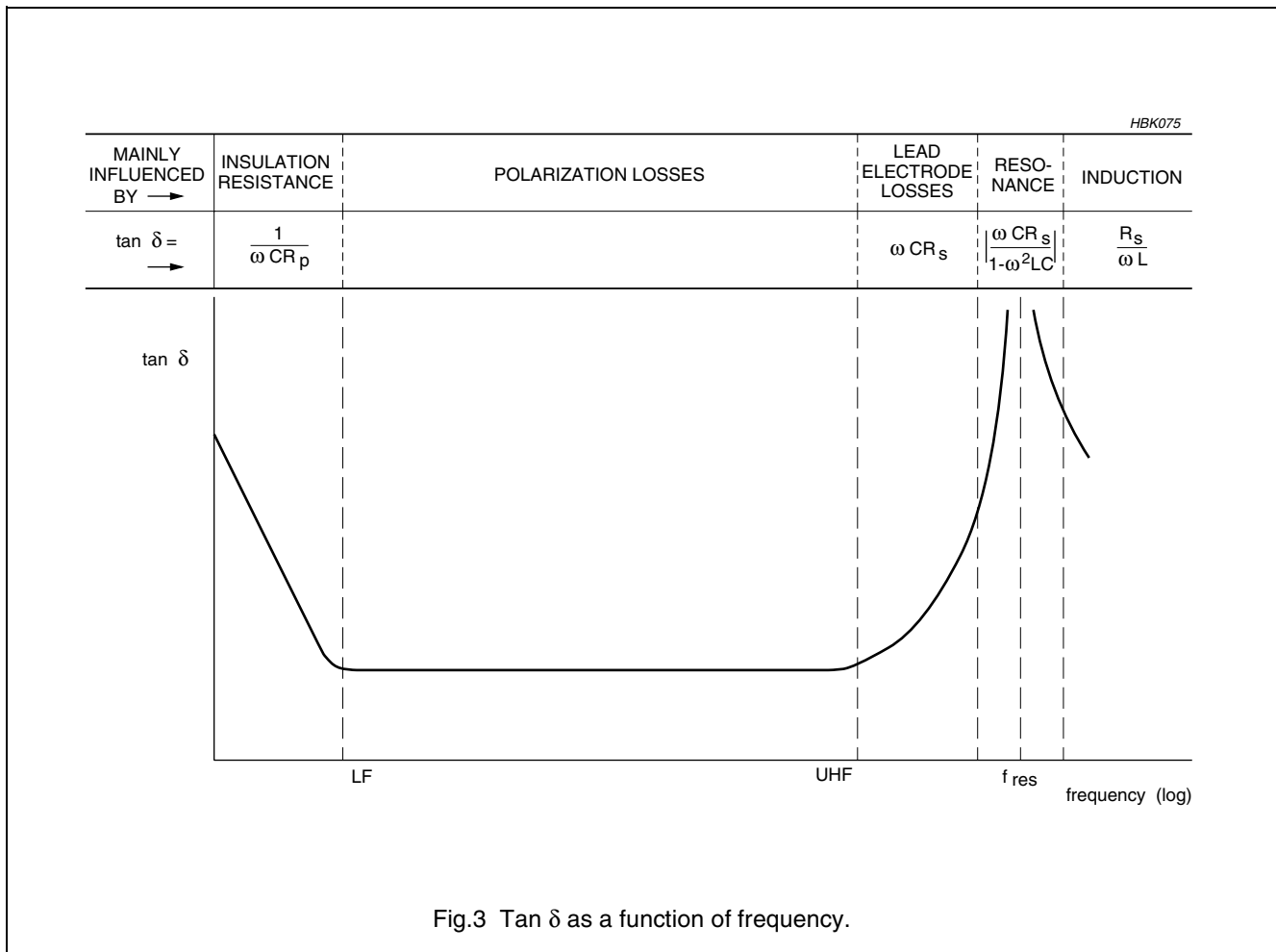

Fig.3 Tan δ as a function of frequency.

Surface-mount ceramic multilayer capacitors

Introduction

RELIABILITY

The failure rates shown in Table 1 have a confidence level of 60% and refer to observations of Multilayer Chip Capacitors (MLCCs) up to and including 1997.

Table 1 Reliability.

CAPACITOR TYPE	NUMBER OF COMPONENT HOURS	FAILURE RATE AT NORMALIZED CONDITIONS
MLCC	32 130 000	2.5 FIT

Remarks

1 FIT = 1 failure rate within 10^9 component hours.

Failure rates are given under normalized conditions, i.e. at $0.5 \times$ rated DC voltage and $T_{amb} = 40\text{ }^\circ\text{C}$.

Failures include capacitance, $\tan \delta$ and insulation resistance values, which do not meet the requirements after endurance test.

The determination of failure rates is based on the rated conditions as stated in "MIL-HDBK-217D". All the test results should be interpreted as results under rated conditions even if the temperature and voltage exceed the rated values.

**Surface-mount ceramic
multilayer capacitors**

Introduction**REVISION HISTORY**

Revision	Date	Change Notification	Description
Rev.7	2001 May 30	–	- Converted to Phycomp brand