

ISSUE NO.	ENG. REF. NO.	DATE	APP. BY
7	-	07/03/17	csmurke

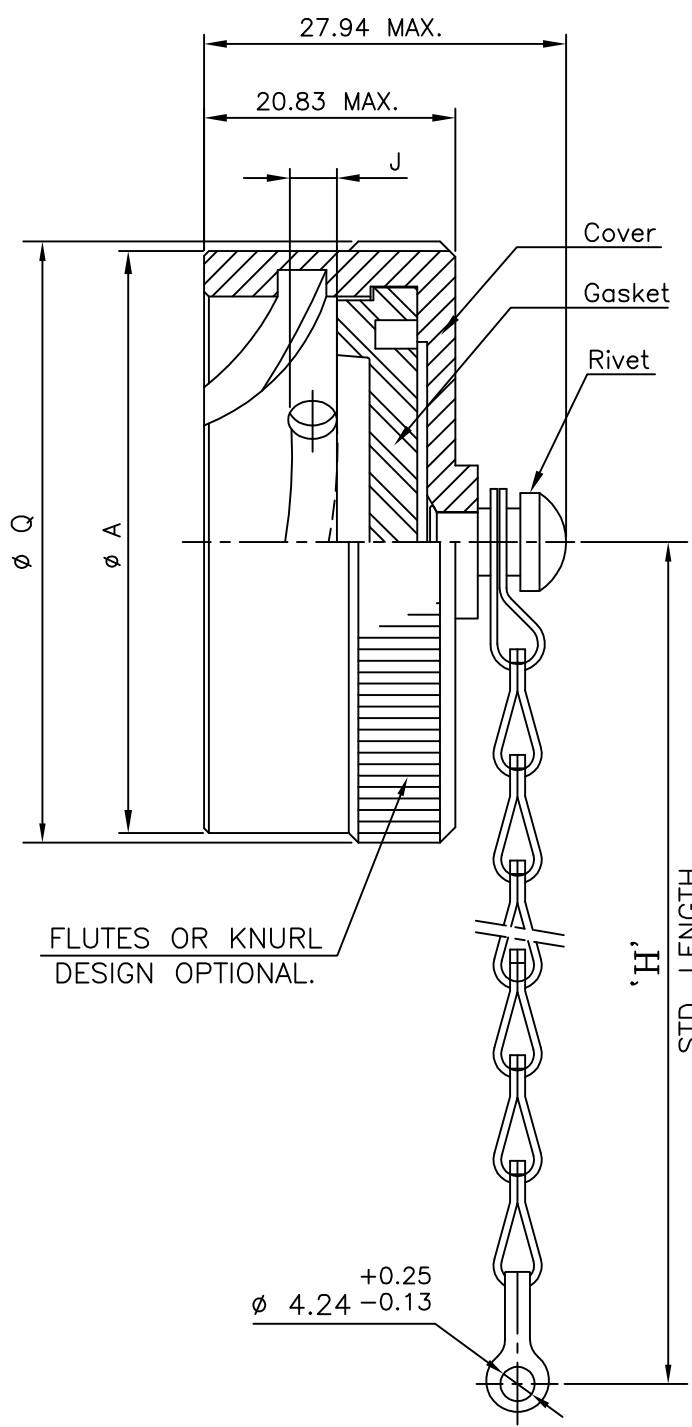

ϕ 4.24 $\begin{matrix} +0.25 \\ -0.13 \end{matrix}$

STYLE 'C'

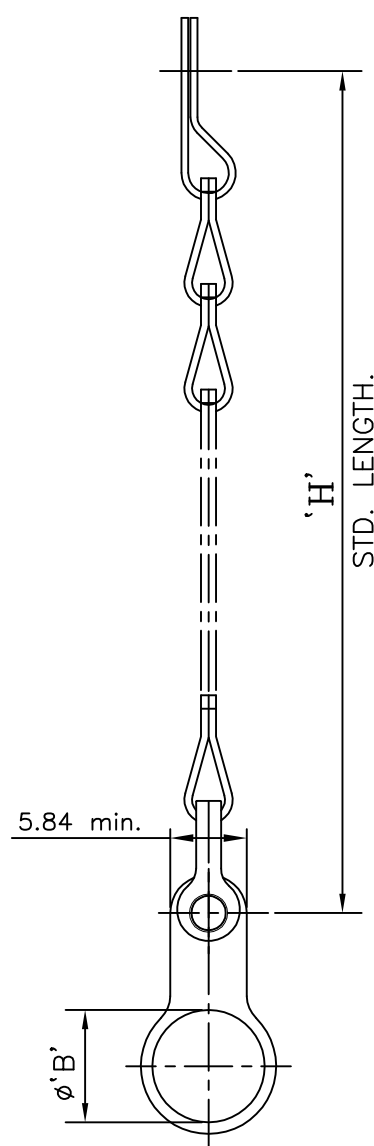

STYLE 'N'

(LJT)

QF-DEV-03 REV-NO. 02	AMPHENOL Amphenol Interconnect India Pvt. Ltd. Pune 411026		TITLE METAL DUST CAP ASSY. FOR D38999 SER-I RECEPT. CONN. (09 TO 25 SIZE)		
	2012 Drawn by <i>Kulkarni</i> 05/12/12 Checked by <i>P.S.Kumar</i> 07/12/12 App. by <i>csmurke</i> 10/12/12	Dwg. Size A4	Dwg. No. PSTD-10163	All Dimensions are in MM/INCHES STANDARD	
Sheet 1 of 5					

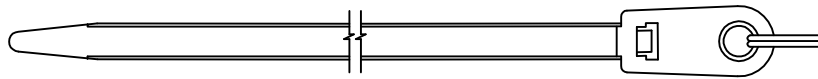

T- Tie Wrap

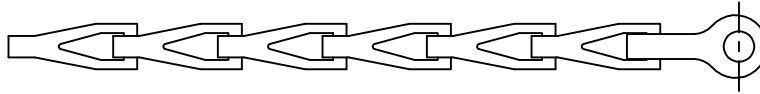

S- Sash Chain

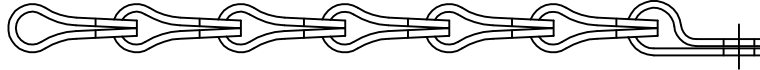

G- Nylon Cord

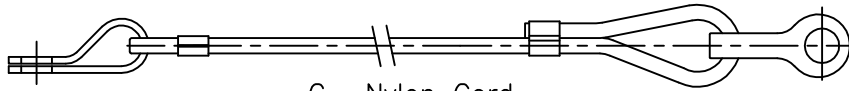

D- Bead chain

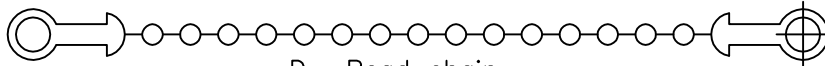

T- (SS) Wire Rope with Teflon Jacket.

All Dimensions are in MM.

SHELL SIZE	∅A MAX.	∅B MIN.	H +12.7 -6.35	J ±0.38	∅Q MAX.
09	20.83	17.78	76.2	2.67	21.84
11	23.88	21.34			24.89
13	27.94	25.65	88.9		29.46
15	30.99	28.96			32.51
17	34.05	32.00			35.81
19	37.08	35.31	101.6		38.61
21	40.13	38.35		41.91	
23	43.18	41.66		44.96	
25	46.48	44.70	3.51	48.01	

All Dimensions for reference only.

QF-DEV-03 REV-NO. 02	AMPHENOL Amphenol Interconnect India Pvt. Ltd. Pune 411026		TITLE METAL DUST CAP ASSY. FOR D38999 SER-I RECEPT. CONN. (09 TO 25 SIZE)		
	2012	Name	Date	Dwg. No.	
	Drawn by <i>Kulkarni</i> 05/12/12 Checked by <i>P.S.Kumar</i> 07/12/12 App. by <i>csmurke</i> 10/12/12	Dwg. Size A4		Dwg. No. PSTD-10163	
Sheet 2 of 5					STANDARD

REQUIREMENTS:

MATERIAL :-

- Cover : Machined Aluminium alloy
- Gasket : Silicone elastomer.
- Ring : Stainless steel, passivated.
- Rope : 7 strand stainless steel passivated with teflon coating.

Fastener : Stainless steel, passivated. Option: Aluminium Integral to cover.

MATING CONNECTOR :- MIL-DTL-38999 series I.

- Gasket shall be mechanically retained.
- Rope shall rotate freely on fastener.

(MILITARY PART NUMBER.)

ORDERING INFORMATION:

JANMS27502 B 11 C L

Designates Receptacle Dust Cover

Class:-
 B - Cadmium plate olive drab finish.
 C - Hard Anodize black finish.
 F - Electroless nickel finish.
 Z - Black Zinc Nickel finish.

Shell Size : 09,11,13,15,17,19,21,23 & 25

Style:-
 C - With Chain
 N - With Chain & Ring
 A - Without Chain

Length
 L- 127.0 +12.7/-6.35 chain/Rope in lieu of std length.
 Leave blank for std. length. 'H'

NOTE:- FOR NON STANDARD LONG 'L' CONTACT FACTORY.

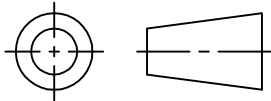
QF-DEV-03 REV-NO. 02 AUTO-CAD 2008	AMPHENOL Amphenol Interconnect India Pvt. Ltd. Pune 411026			TITLE METAL DUST CAP ASSY. FOR D38999 SER-I RECEPT. CONN. (09 TO 25 SIZE)		
	2012 Drawn by <i>Kulkarni</i> 05/12/12 Checked by <i>P.S. Kumar</i> 07/12/12 App. by <i>cmurke</i> 10/12/12	Name Date	Dwg. Size A4	Dwg. No. PSTD-10163	All Dimensions are in MM/INCHES	
					Sheet 3 of 5	STANDARD

(PROPRIETARY PART NUMBER.)

REQUIREMENTS:

MATERIAL :

Cover : Machined Aluminium alloy
 Gasket : Silicone elastomer.
 Fastener : S/Steel, passivated.

ILJT27502 - 09 - A - D - S - H

ORDERING INFORMATION:

Designates:- Receptacle dust cover

Shell size : 09,11,13,15,17,19,21,23 & 25

Finishes:
 A - Hard anodic non conductive
 W - Cadmium palte with olive drab
 E - Electroless nickel.
 X - Zinc cobalt black.
 Z - Zink cobalt olive drab

Type of attachment:
 D - Bead chain passivated.
 G - Nylon cord
 S - Sash chain passivated.
 T - S.S. wire rope with teflon jacket
 X - None

Type of end link:
 S - Solid ring
 T - Tie wrqp
 X - None (small link hole dia 4.49 mm max)

Length of attachment:
 H - Standard length
 For non-standard 'H', length has to be specified in inches.

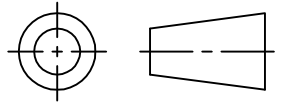
QF-DEV-03 REV-NO. 02	<p align="center">AMPHENOL Amphenol Interconnect India Pvt. Ltd. Pune 411026</p>			TITLE METAL DUST CAP ASSY. FOR D38999 SER-I RECEPT. CONN. (09 TO 25 SIZE)		
	2012	Name	Date	Dwg. Size	Dwg. No.	
	Drawn by <i>Kulkarni</i> 05/12/12 Checked by <i>R.S.Kumar</i> 07/12/12 App. by <i>csmurke</i> 10/12/12	A4		PSTD-10163		STANDARD

STYLE-A

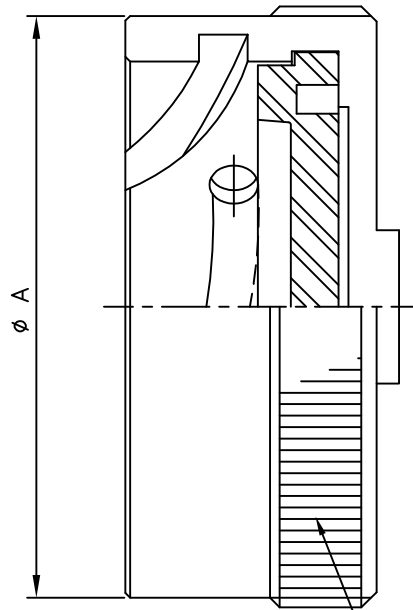

REQUIREMENTS:

MATERIAL :

Cover : Machined Aluminium alloy

Gasket : Silicone elastomer.

MATING CONNECTOR: MIL-C-38999 Series I.

Gasket shall be mechanically retained.

ORDERING INFORMATION:

ILJT27502 - 08 - A - V1

Designates : Receptacle dust cover

Shell size : 09,11,13,15,17,19,21,23 & 25

Class
 A - Hard anodic
 W - Aluminium, 500 Hrs cadmium olive drab.
 F - Aluminium, 48 Hrs. electroless nickel.
 T - Nickel PTFE finish.

VARIANT

QF-DEV-03 REV-NO. 02	AUTO-CAD 2008	AMPHENOL Amphenol Interconnect India Pvt. Ltd. Pune 411026	TITLE METAL DUST CAP ASSY. FOR D38999 SER-I RECEPT. CONN. (09 TO 25 SIZE)			
	2012	Name	Date	Dwg. Size	Dwg. No.	All Dimensions are in MM/INCHES
	Drawn by	<i>Kulkarni</i>	05/12/12	A4	PSTD-10163	STANDARD
Checked by	<i>P.S. Kumar</i>	07/12/12	Sheet 5 of 5			
App. by	<i>csmurke</i>	10/12/12				