

THIS INFORMATION IS CONFIDENTIAL AND IS DISCLOSED TO YOU ON CONDITION THAT NO FURTHER DISCLOSURE IS MADE BY YOU TO OTHER THAN AMP PERSONNEL WITHOUT WRITTEN AUTHORIZATION FROM AMP (TAIWAN) LTD. DIMENSIONS IN MILLIMETERS. DO NOT SCALE PRINT.

NUMBER
C-1734517

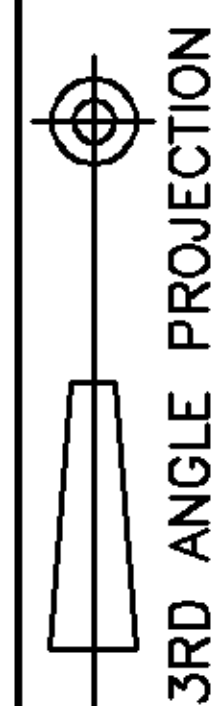

METRIC

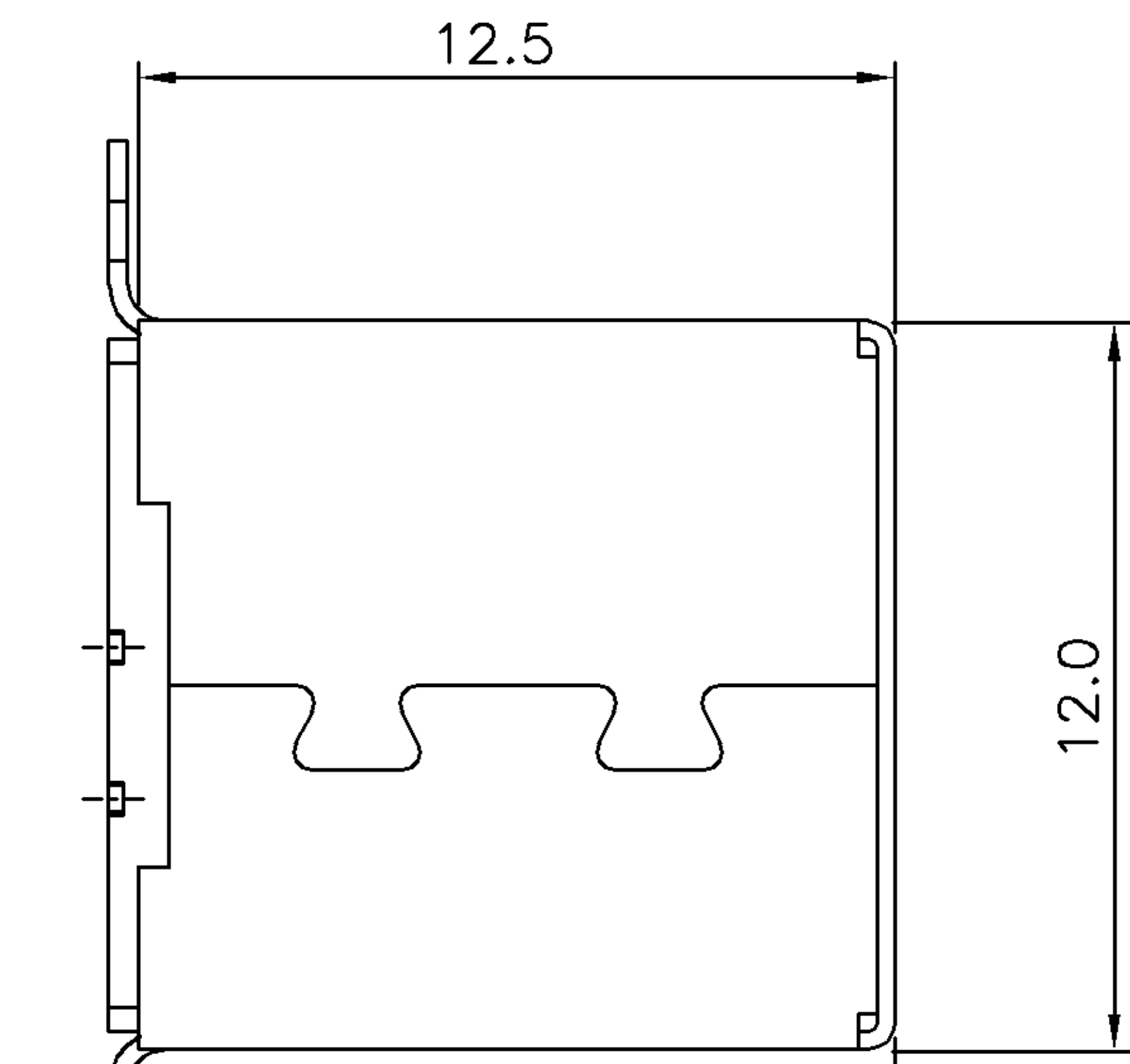

0.10
ALL SOLDER TAILS AND PEGS

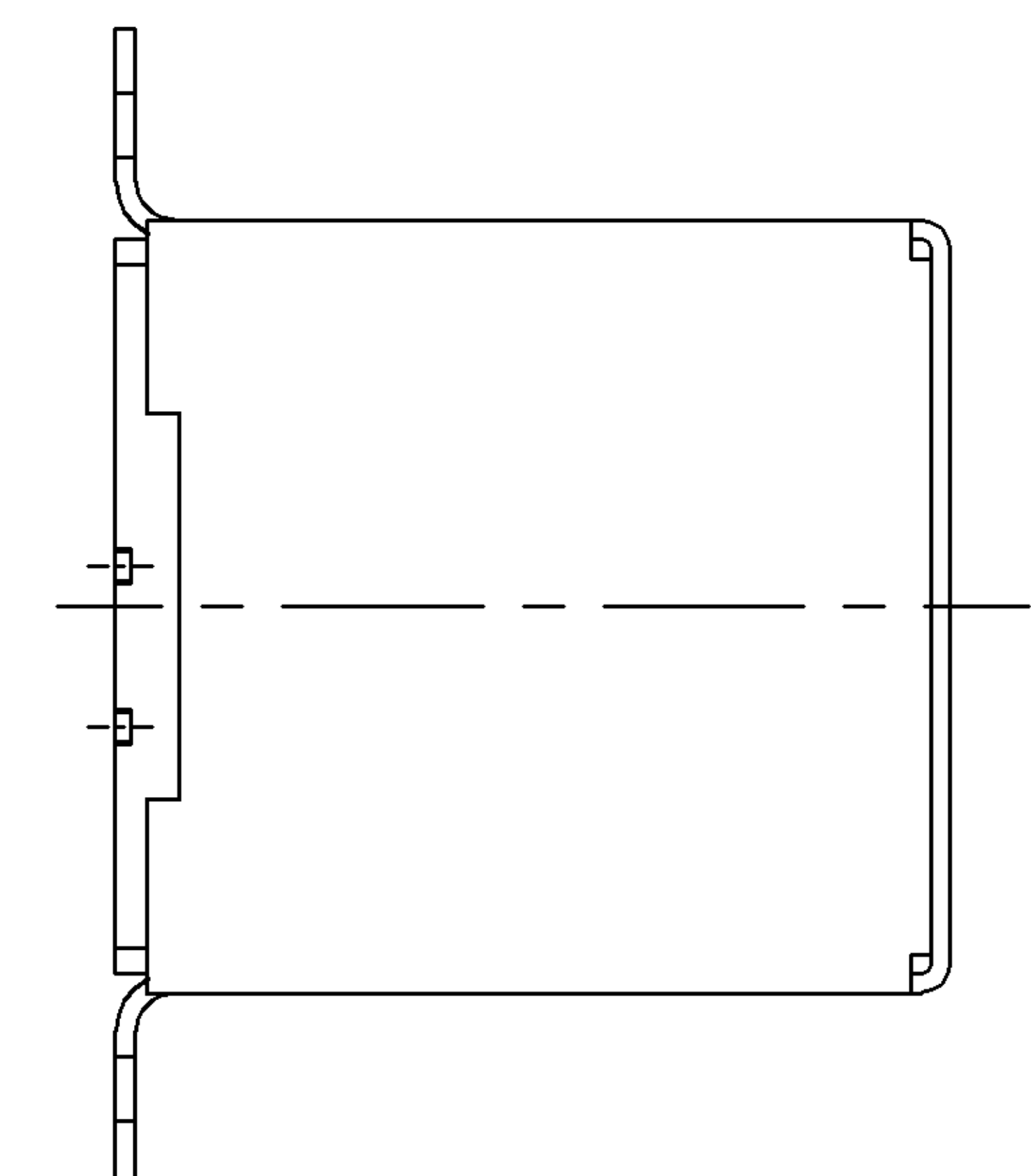
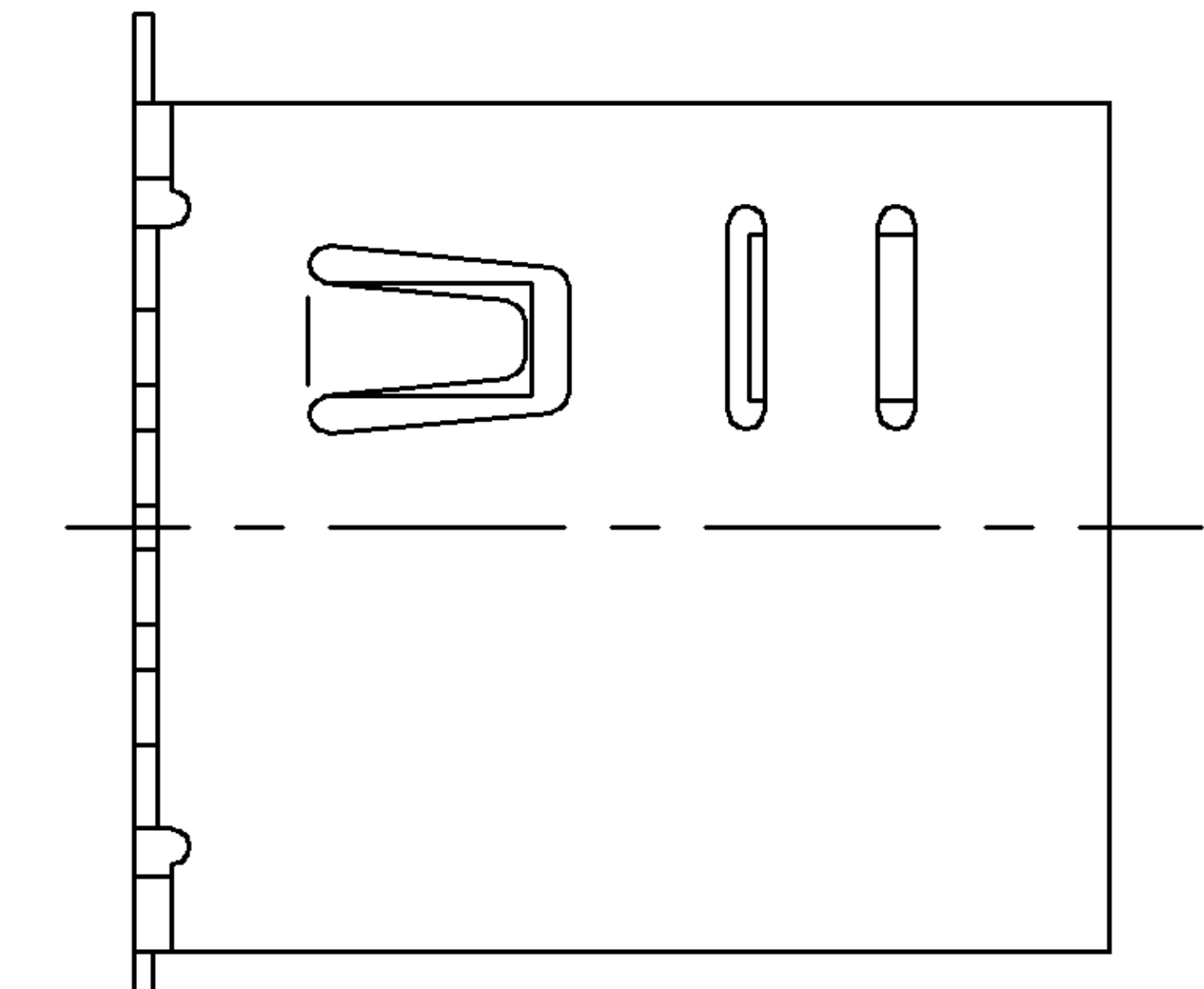

NOTES :

1. MATERIAL:
HOUSING: THERMOPLASTIC, UL 94V-0, COLOR: BLACK.
CONTACT: PHOSPHOR BRONZE, THICKNESS=0.25mm.
SHELL: PHOSPHOR BRONZE, THICKNESS=0.30mm.
2. FINISH:
CONTACT: GOLD PLATING (SEE TABLE) ON CONTACT AREA,
100u" MIN. TIN-Cu PLATING ON SOLDER TAILS,
50u" MIN. NICKEL UNDERPLATED OVER ALL.
SHELL: 100u" MIN. NICKEL PLATED OVER 50u" MIN. Cu UNDERPLATED.
3. REFLOW SOLDER CAPABLE TO 260°C PER TYCO SPEC 109-201, CONDITION B.

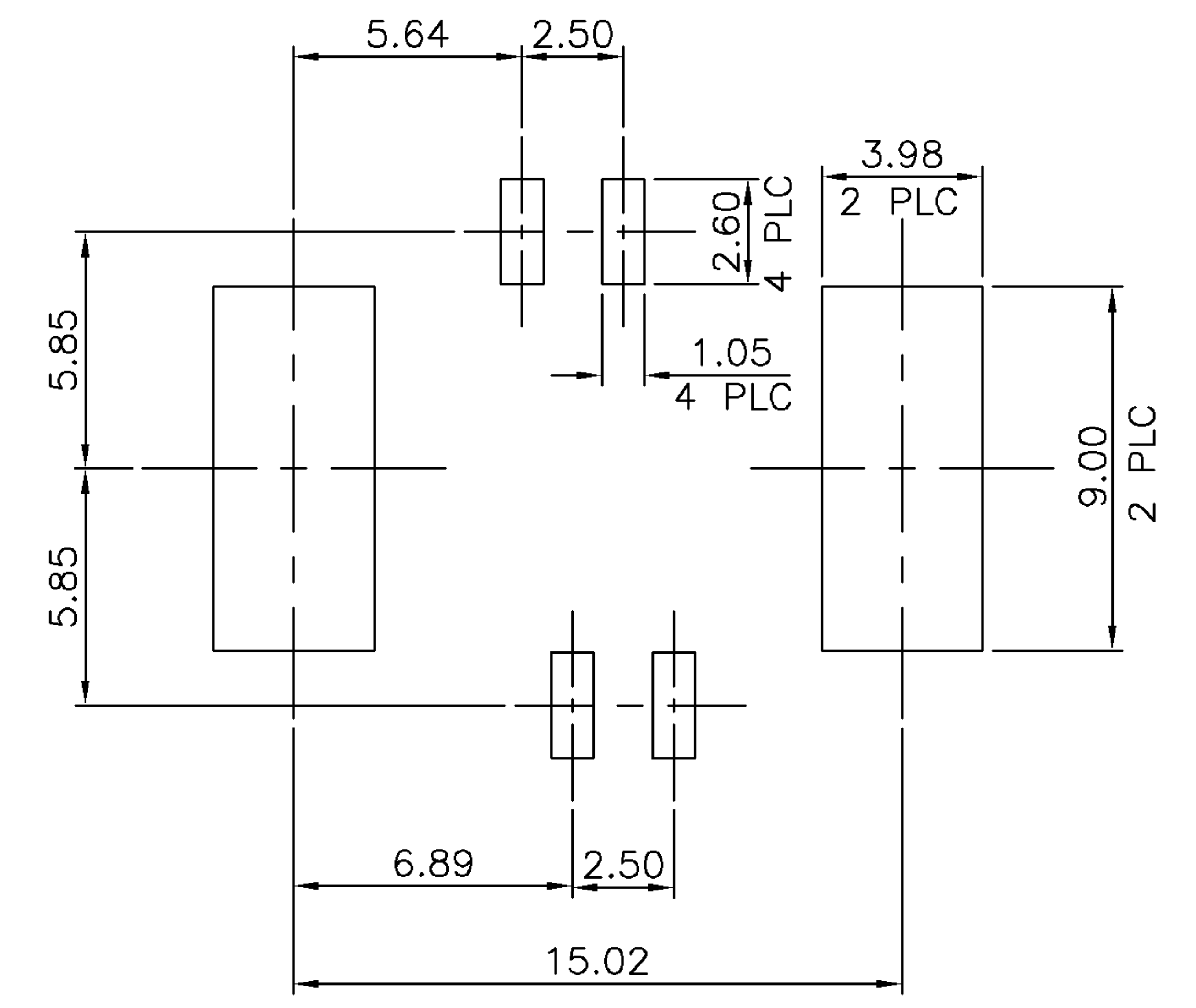
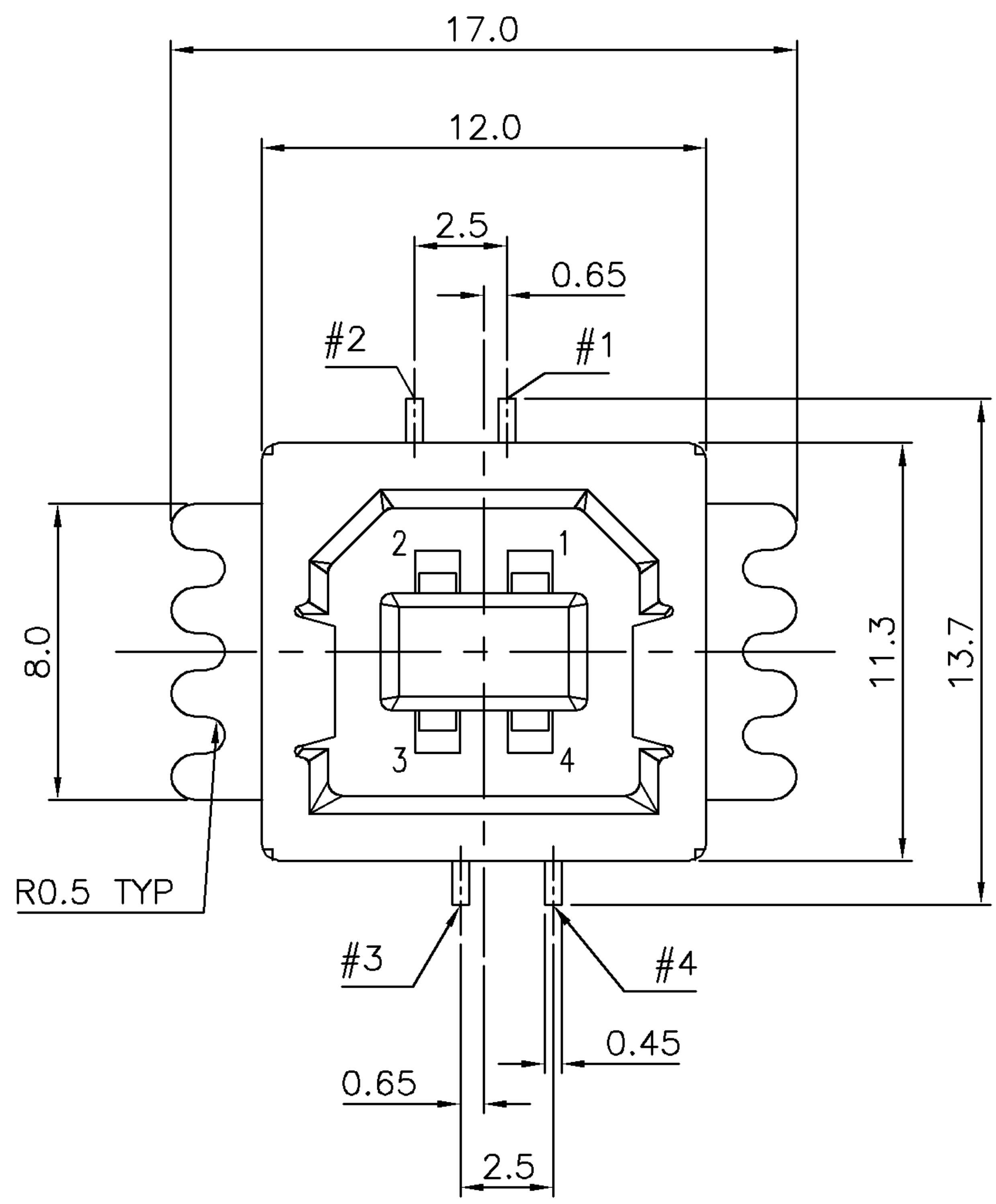

RECOMMENDED PCB LAYOUT
(TOLERANCE: ±0.05)

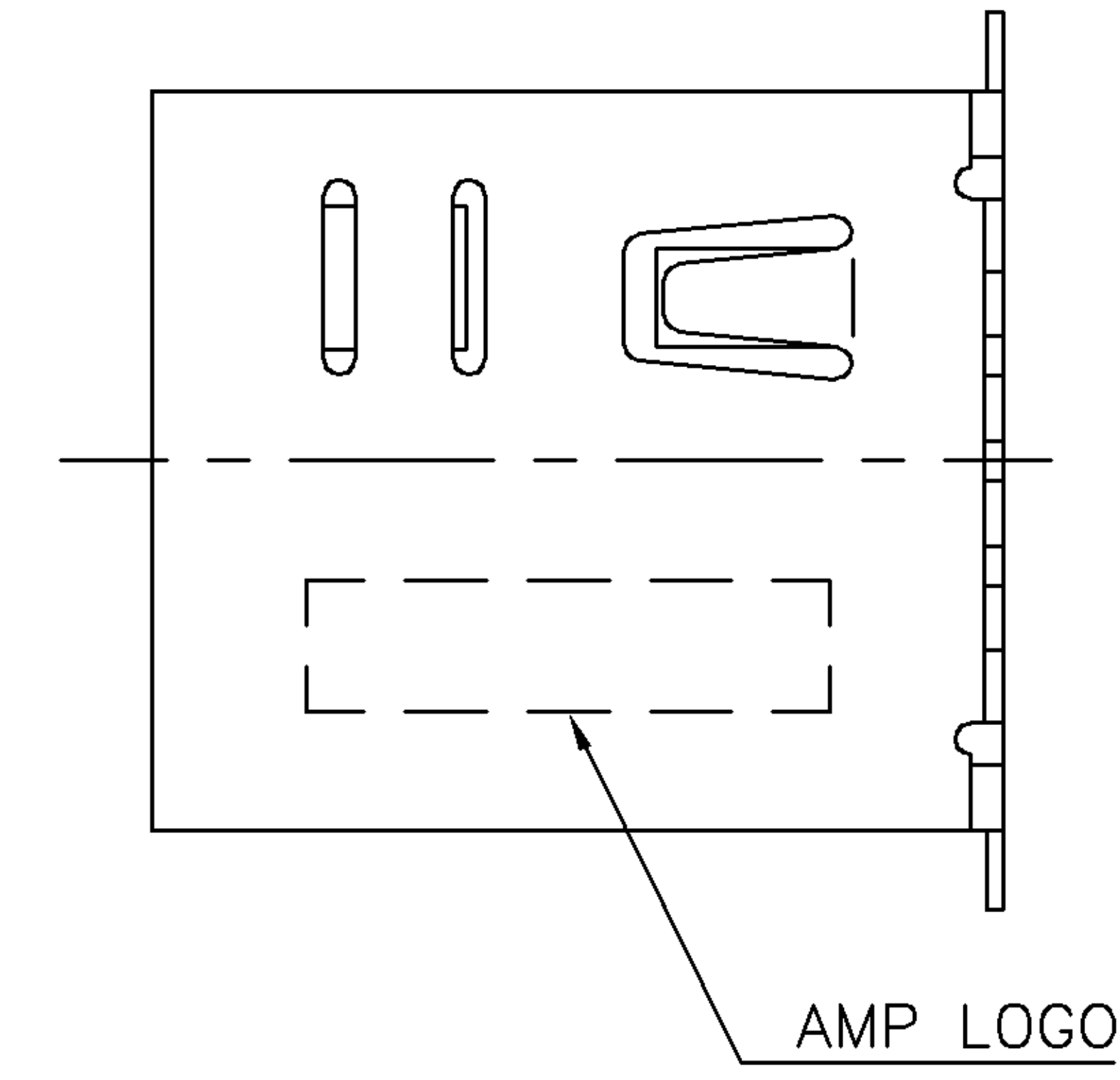

30μ"	1734517-1
MIN. GOLD THICKNESS	PART NUMBER

TOLERANCES UNLESS OTHERWISE SPECIFIED: 0 PLC ±0.38 1 PLC ±0.25 2 PLC ±0.13 3 PLC ±0.05 ANGLES ±3'	DWN	O. HU	TYCO HOLDINGS (BERMUDA) VII LTD. TAIWAN BRANCH			
		22-JUN-2006				
MATERIAL SEE NOTE	CHK	S. HOU	NAME USB B TYPE, TOP ENTRY, 4 POSITION, SMT TYPE			
		22-JUN-2006				
FINISH SEE NOTE	APVD	W.J. KE	LOC DW A ₃			
		22-JUN-2006				
	PRODUCT SPEC	108-57538	DRAWING NO	C-1734517	REV	A
	QUALIFICATION TEST REPORT	501-57618	SCALE	--	SHEET	1 OF 2
	WEIGHT					

A	FIRST RELEASED		OH SH	23/JUN 2006
LTR	REVISION RECORD	ECN	DWN CHK	DATE

THIS INFORMATION IS CONFIDENTIAL AND IS DISCLOSED TO YOU ON CONDITION THAT NO FURTHER DISCLOSURE IS MADE BY YOU TO OTHER THAN AMP PERSONNEL WITHOUT WRITTEN AUTHORIZATION FROM AMP (TAIWAN) LTD. DIMENSIONS IN MILLIMETERS. DO NOT SCALE PRINT.

NUMBER
C-1734517

3RD ANGLE PROJECTION

METRIC

PRINT
DW

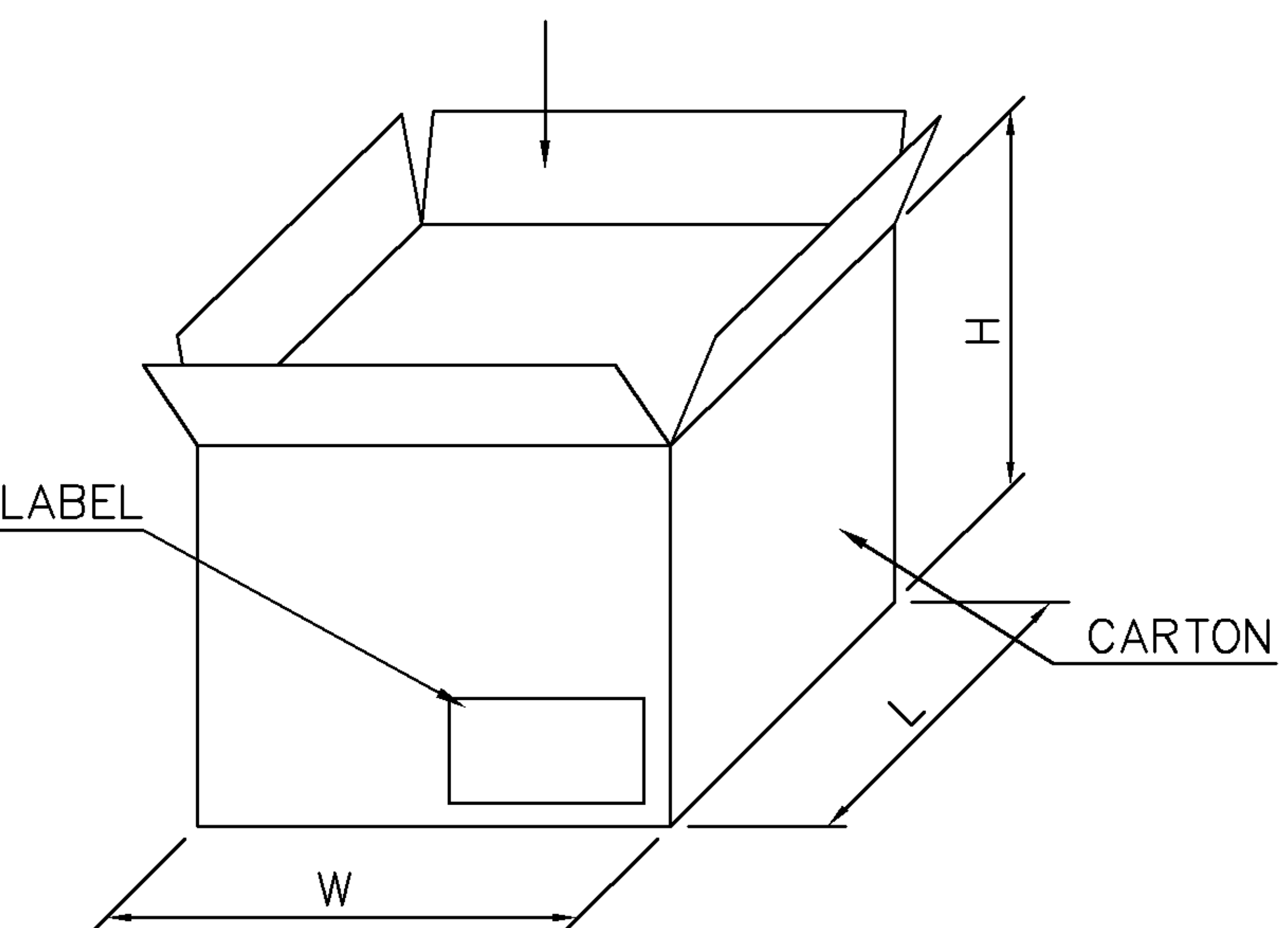
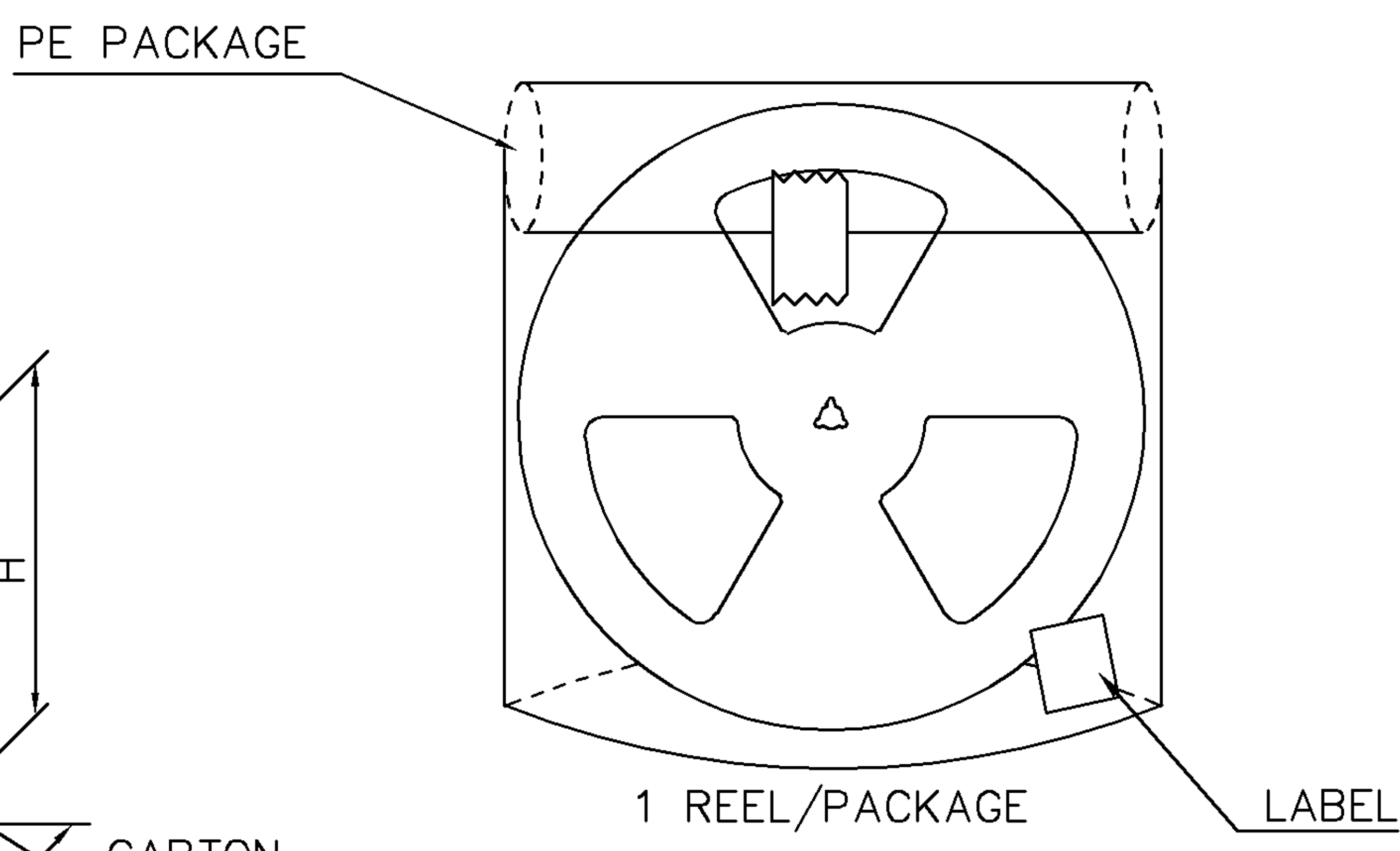
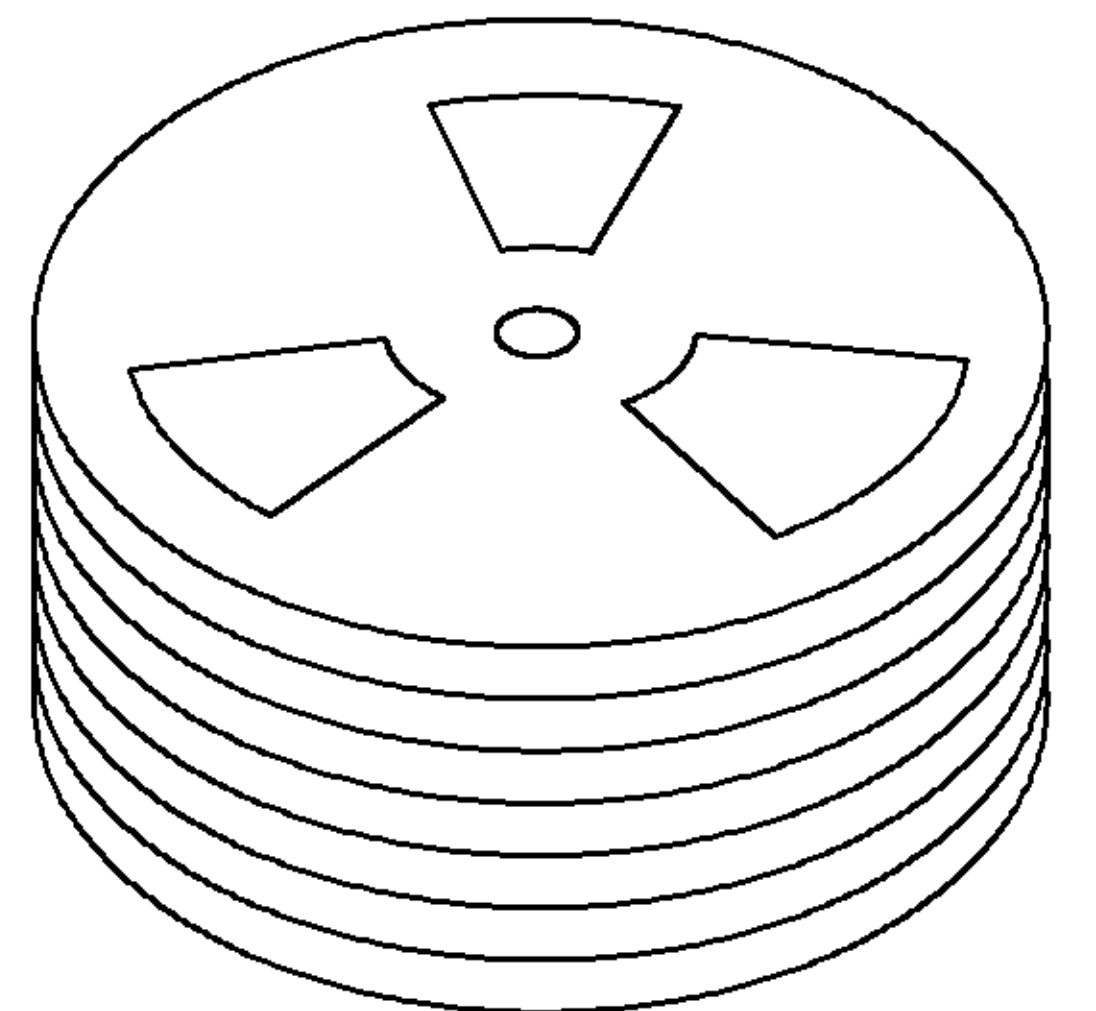
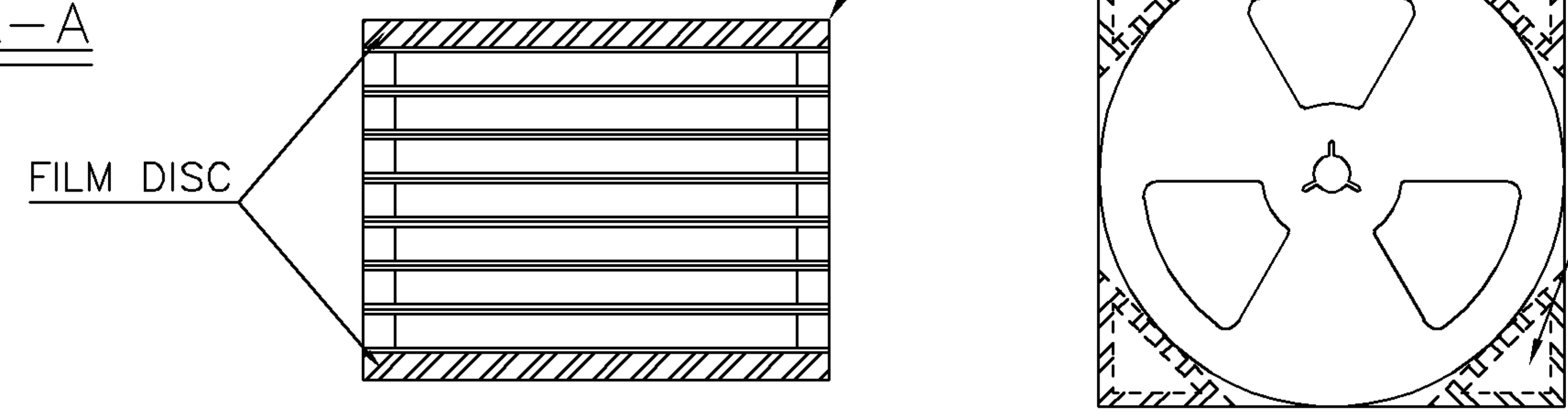
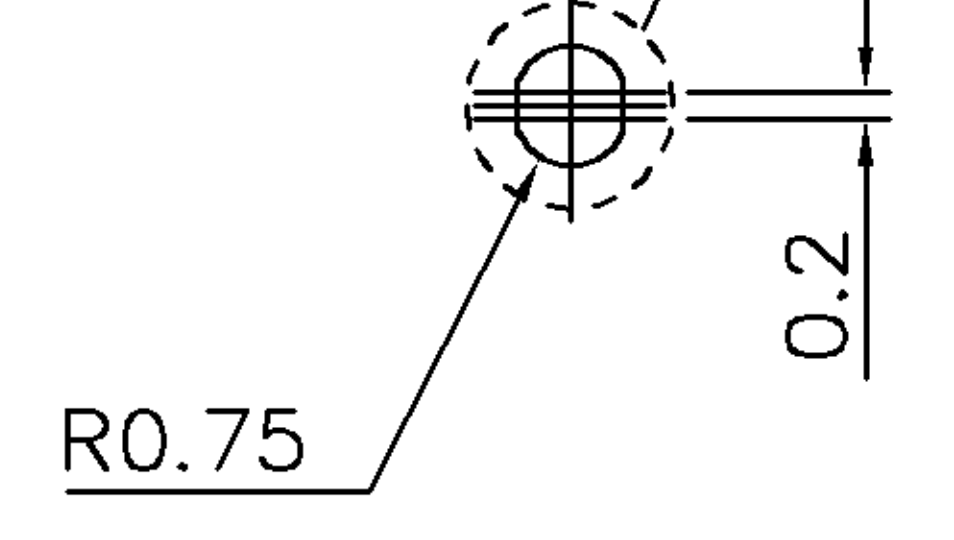
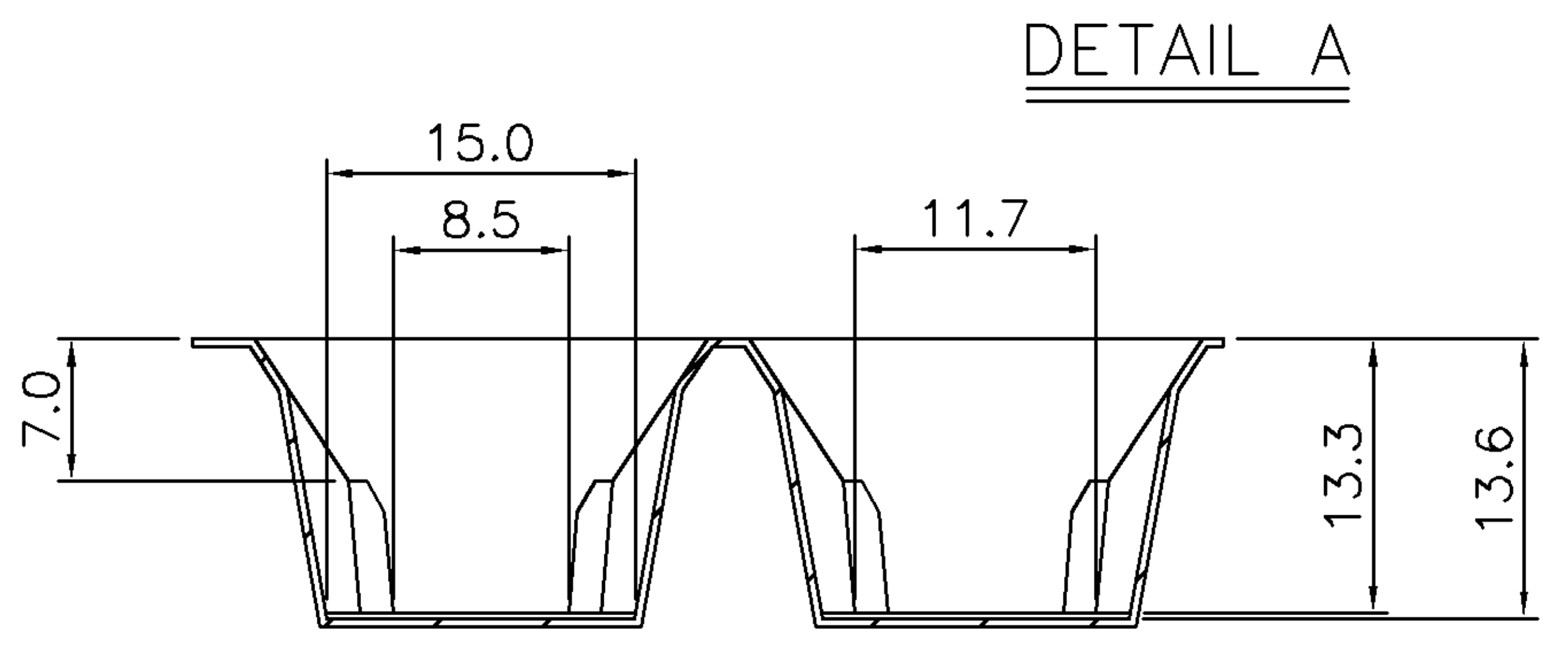
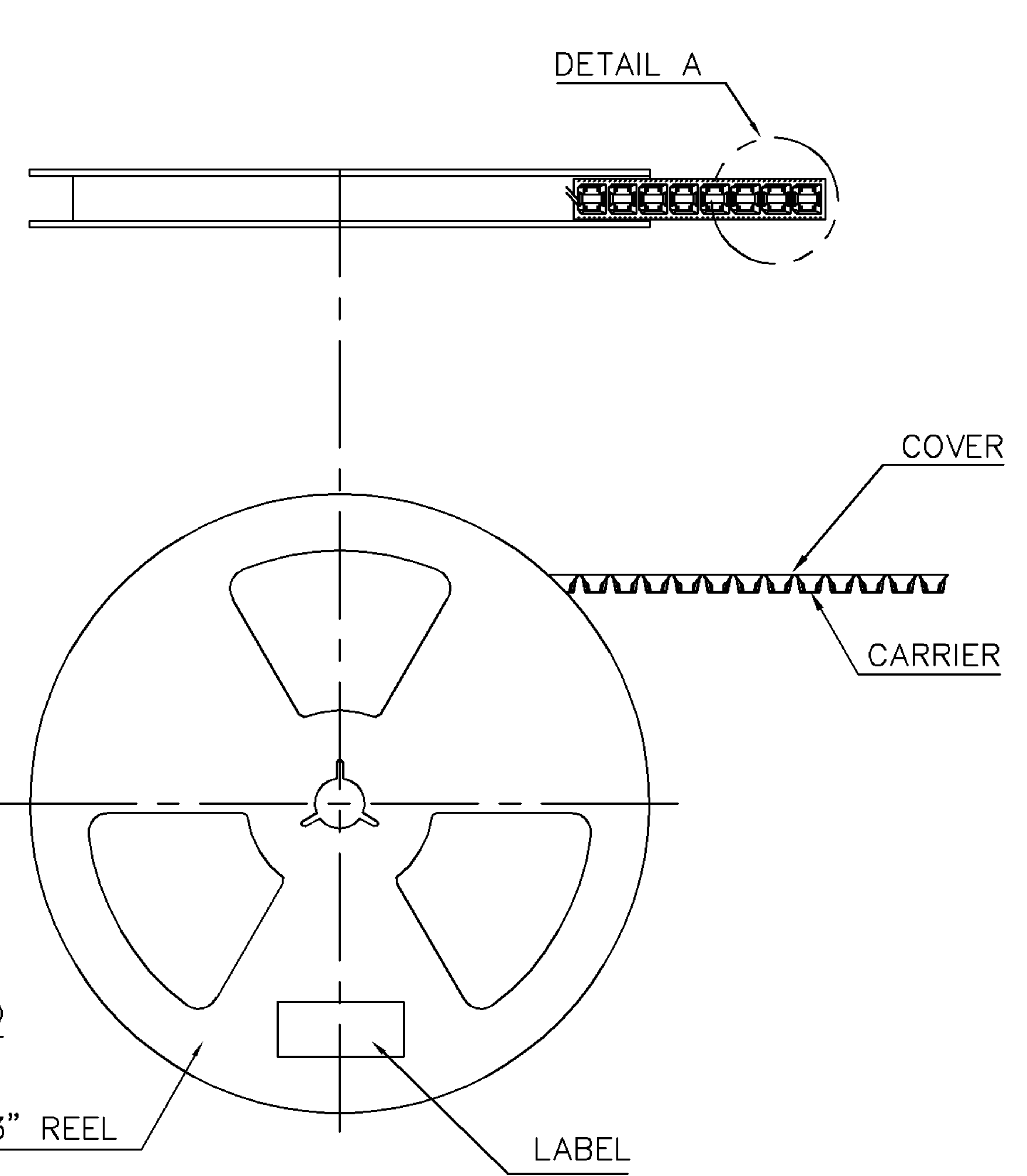
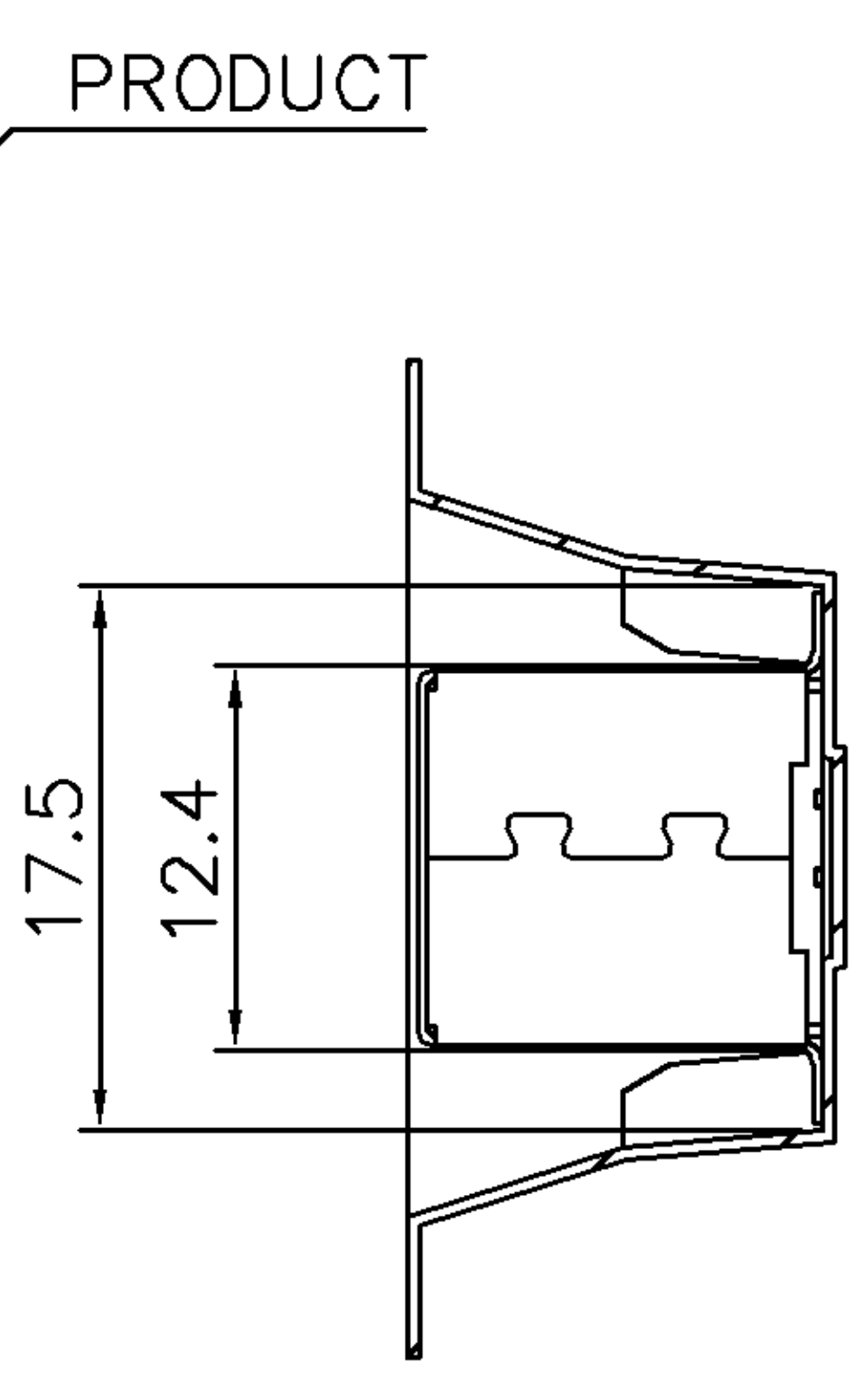
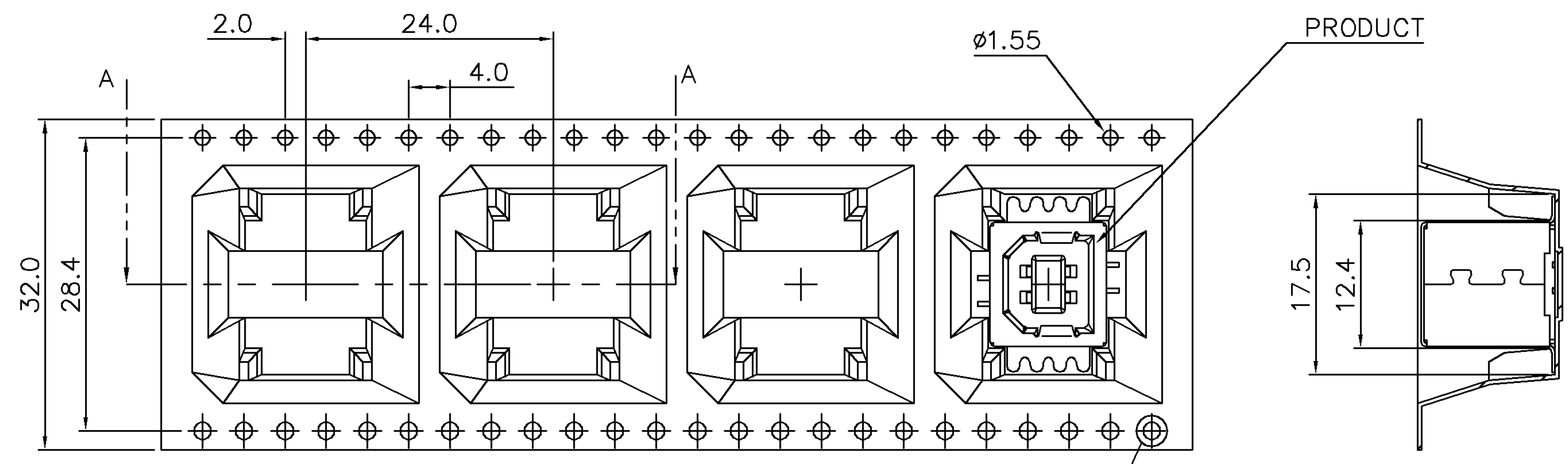

- NOTES :
- MATERIAL :
 - EMBOSSED CARRIER: PS.
 - COVER: PET.
 - CARTON: K=A.
 - DIMENSION :
 - REEL: W=32.0.
 - CARTON: L=348, W=348, H=340.
 - QUANTITY :
 - PRIMARY PACKING: 200PCS/REEL.
 - SECONDARY PACKING: 8 REEL/CARTON(1,600PCS).
 - WEIGHT :
 - NET WEIGHT: 8.0kg/CARTON.
 - GROSS WEIGHT: 9.0kg/CARTON.
 - PEELING RESISTANCE: 10g~130g.

TOLERANCES UNLESS OTHERWISE SPECIFIED:		DWN	O. HU	tyco Electronics	TYCO HOLDINGS (BERMUDA) VII LTD. TAIWAN BRANCH		
0 PLC	±		22-JUN-2006				
1 PLC	±	CHK	S. HOU	NAME			
2 PLC	±		22-JUN-2006				
3 PLC	±						
ANGLES	±						
MATERIAL	SEE NOTE	APVD	W.J. KE	USB B TYPE, TOP ENTRY, 4 POSITION, SMT TYPE			
			22-JUN-2006				
FINISH	SEE NOTE	APPLICATION SPEC	-	LOC	SIZE	DRAWING NO	REV
		WEIGHT	-	DW	A ₃	C-1734517	A
				SCALE	--	SHEET	2 OF 2

SEE SHEET 1.	ECN	DWN	CHK	DATE
LTR	REVISION RECORD			