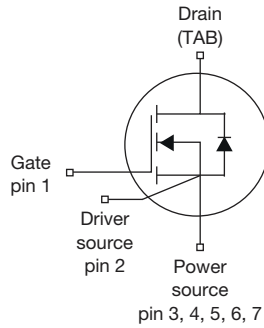
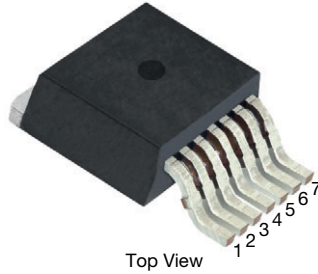

MaxSiC[®] 1200 V N-Channel SiC MOSFET

D²PAK 7L (TO-263 7L)

Marking Code: 120A063SE

FEATURES

- Fast switching speed
- Short circuit withstand time 3 μ s
- Material categorization: for definitions of compliance please see www.vishay.com/doc?99912

RoHS
 COMPLIANT
 HALOGEN
FREE
APPLICATIONS

- Solar inverters
- Energy storage systems
- UPS (uninterruptible power supplies)

PRODUCT SUMMARY	
V_{DS} (V) at T_J max.	1200
$R_{DS(on)}$ typ. ($m\Omega$) at 25 °C	$V_{GS} = 18$ V 63
Q_g typ. (nC)	58
I_D (A)	41
C_{oss} typ. (pF)	69
P_D (W)	221
Configuration	Single

ORDERING INFORMATION	
Package	D ² PAK 7L (TO-263 7L)
Lead (Pb)-free and halogen-free	MXP120A063SE-T1GE3

ABSOLUTE MAXIMUM RATINGS ($T_C = 25$ °C, unless otherwise noted)				
PARAMETER	SYMBOL	LIMIT	UNIT	
Drain-source voltage	V_{DS}	1200	V	
Gate-source voltage	V_{GS}	-10 / +22		
Recommended operation voltage of gate-source	V_{GSOP}	-5 to -3 / +18		
Continuous drain current	$T_C = 25$ °C	I_D	41	A
Pulsed drain current ^a		I_{DM}	82	
Short-circuit withstand time ^b		T_{SC}	3	μ s
Maximum power dissipation	$T_C = 25$ °C	P_D	221	W
Operating junction and storage temperature range		T_J, T_{stg}	-55 to +175	°C
Soldering recommendations (peak temperature)	For 10 s		260	°C
Single pulse avalanche energy ^c		E_{AS}	162	mJ

Notes

- Repetitive rating; pulse width limited by maximum junction temperature
- $V_{GS} = 18$ V, $V_{DS} = 800$ V, $R_{g(ext)} = 20$ Ω , verified by the design / characterization
- $T_J = 25$ °C, $V_{DD} = 120$ V, $L = 1$ mH, $V_{GS} = 18$ V, $I_{AS} = 18$ A, verified by the design / characterization



THERMAL RESISTANCE RATINGS				
PARAMETER	SYMBOL	TYP.	MAX.	UNIT
Maximum junction-to-ambient	R_{thJA}	-	40	°C/W
Maximum junction-to-case (drain)	R_{thJC}	-	0.68	

SPECIFICATIONS ($T_J = 25\text{ °C}$, unless otherwise noted)							
PARAMETER	SYMBOL	TEST CONDITIONS	MIN.	TYP.	MAX.	UNIT	
Static							
Drain-source breakdown voltage	V_{DS}	$V_{GS} = 0\text{ V}, I_D = 1\text{ mA}$	1200	-	-	V	
Gate-source threshold voltage (N)	$V_{GS(th)}$	$V_{DS} = V_{GS}, I_D = 3.5\text{ mA}$	-	2.9	-	V	
		$V_{DS} = V_{GS}, I_D = 3.5\text{ mA}, T_J = 175\text{ °C}$	-	2.0	-	V	
Gate-source leakage	I_{GSS}	$V_{GS} = 22\text{ V}, V_{DS} = 0\text{ V}$	-	-	100	nA	
		$V_{GS} = -10\text{ V}, V_{DS} = 0\text{ V}$	-	-	-100		
Zero gate voltage drain current	I_{DSS}	$V_{DS} = 1200\text{ V}, V_{GS} = 0\text{ V}$	-	-	10	μA	
Drain-source on-state resistance	$R_{DS(on)}$	$V_{GS} = 15\text{ V}, I_D = 18\text{ A}$	-	75	94	mΩ	
		$V_{GS} = 18\text{ V}, I_D = 18\text{ A}$	-	63	79		
		$V_{GS} = 18\text{ V}, I_D = 18\text{ A}, T_J = 175\text{ °C}$	-	107	-		
Transconductance	g_{fs}	$V_{DS} = 10\text{ V}, I_D = 18\text{ A}$	-	8	-	S	
Dynamic							
Input capacitance	C_{iss}	$V_{GS} = 0\text{ V}, V_{DS} = 800\text{ V}, f = 100\text{ KHz}$	-	1699	-	pF	
Output capacitance	C_{oss}		-	69	-		
Reverse transfer capacitance	C_{rss}		-	3	-		
Total gate charge	Q_g	$V_{GS} = -5\text{ V} \sim 18\text{ V}, I_D = 18\text{ A}, V_{DS} = 800\text{ V}$	-	58	-	nC	
Gate-source charge	Q_{gs}		-	16	-		
Gate-drain charge	Q_{gd}		-	16	-		
Gate Resistance	R_g		$V_{DS} = 0\text{ V}, f = 1\text{ MHz}$	-	3		-
Switching Characteristics							
Turn-on delay time	$t_{d(on)}$	$V_{GS} = -5\text{ V} \sim 18\text{ V}, I_D = 18\text{ A}, V_{DS} = 800\text{ V}, R_{g(ext)} = 4.4\text{ Ω}$	$T_J = 25\text{ °C}$	-	18	-	ns
			$T_J = 175\text{ °C}$	-	18	-	
Rise time	t_r		$T_J = 25\text{ °C}$	-	9	-	
			$T_J = 175\text{ °C}$	-	8	-	
Turn-off delay time	$t_{d(off)}$		$T_J = 25\text{ °C}$	-	19	-	
			$T_J = 175\text{ °C}$	-	20	-	
Fall time	t_f		$T_J = 25\text{ °C}$	-	10	-	
			$T_J = 175\text{ °C}$	-	10	-	
Turn-on switching energy	E_{on}		$T_J = 25\text{ °C}$	-	191	-	μJ
			$T_J = 175\text{ °C}$	-	178	-	
Turn-off switching energy	E_{off}		$T_J = 25\text{ °C}$	-	51	-	
			$T_J = 175\text{ °C}$	-	50	-	
Body Diode Ratings and Characteristic							
Forward diode voltage	V_{SD}	$V_{GS} = -5\text{ V}, I_{SD} = 9\text{ A}, T_J = 25\text{ °C}$	-	4.8	-	V	
Continuous diode forward current	I_{SD}	$V_{GS} = -5\text{ V}, T_J = 25\text{ °C}$	-	-	33	A	
Pulsed diode forward current	I_{SDM}		-	-	82		
Reverse recovery time	t_{rr}	$V_{GS} = -5\text{ V}, I_{SD} = 18\text{ A}, V_R = 800\text{ V}, di/dt = 1000\text{ A/μs}$	-	18	-	ns	
Reverse recovery charge	Q_{rr}		-	60	-	nC	
Reverse recovery current	I_{RRM}		-	6	-	A	



TYPICAL CHARACTERISTICS (25 °C, unless otherwise noted)

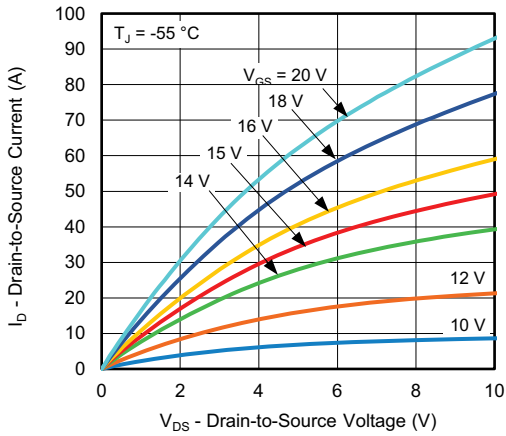

Fig. 1 - Typical Output Characteristics

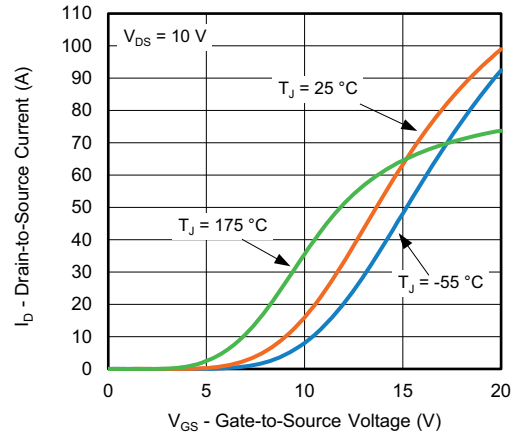

Fig. 4 - Typical Transfer Characteristics

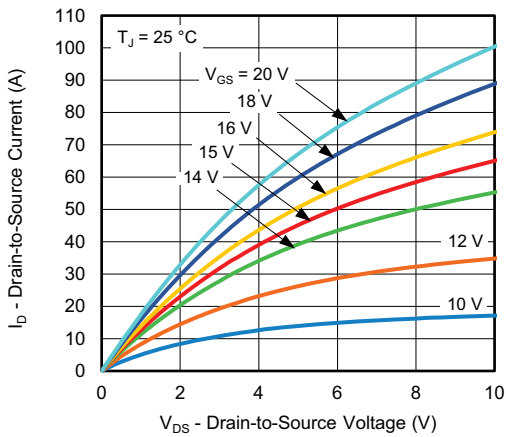

Fig. 2 - Typical Output Characteristics

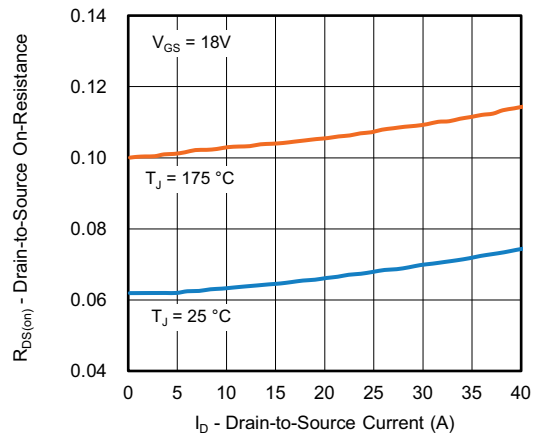

Fig. 5 - Normalized On-Resistance vs. Drain Current

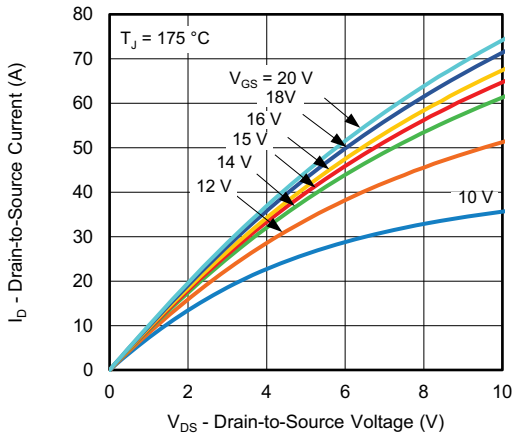

Fig. 3 - Typical Output Characteristics

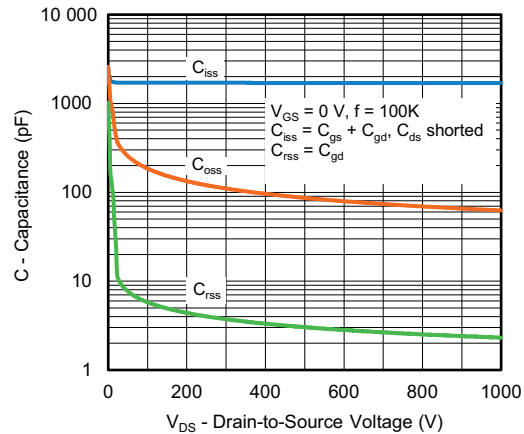

Fig. 6 - Typical Capacitance vs. Drain-to-Source Voltage

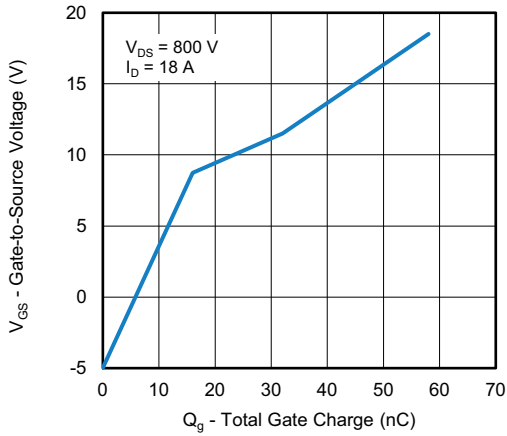

Fig. 7 - Typical Gate Charge vs. Gate-to-Source Voltage

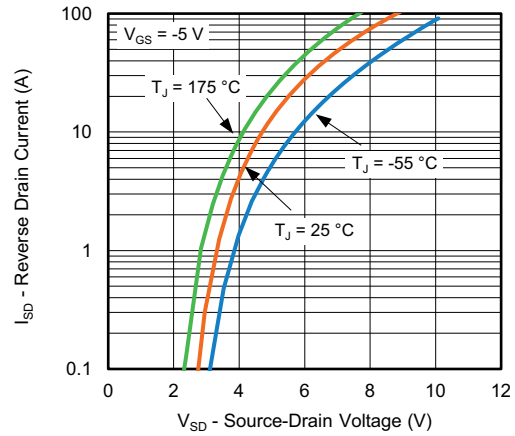

Fig. 10 - Typical Source-Drain Diode Forward Voltage

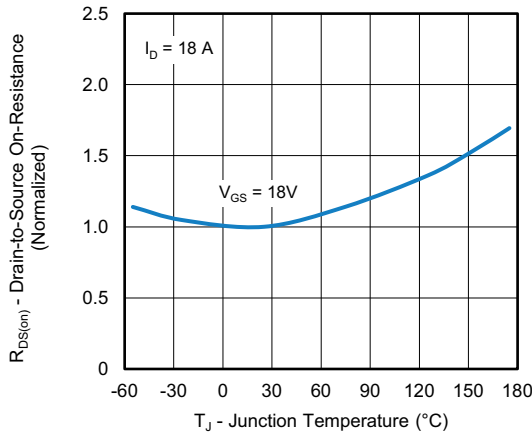

Fig. 8 - Normalized On-Resistance vs. Temperature

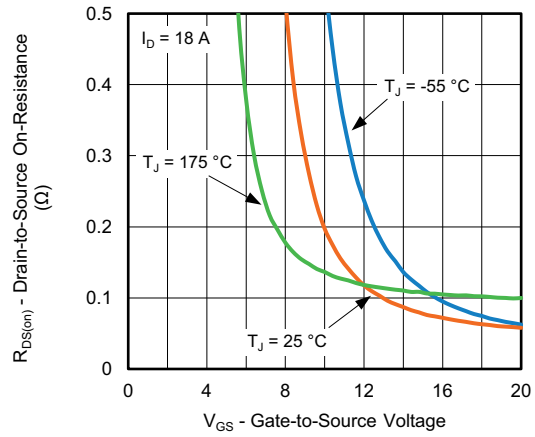

Fig. 11 - On-Resistance vs. Gate-to-Source Voltage

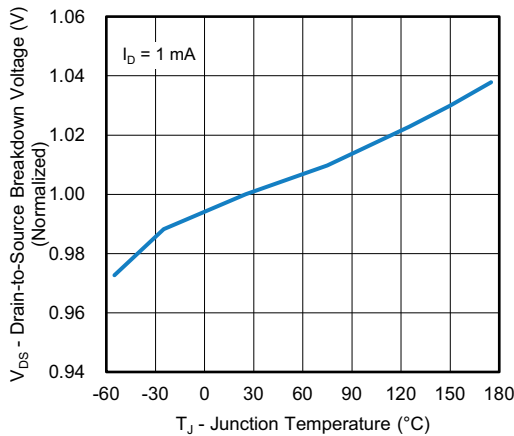

Fig. 9 - Drain-to-Source Voltage vs. Temperature

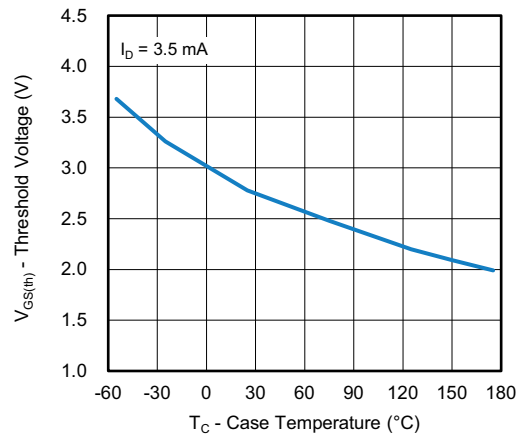

Fig. 12 - Threshold Voltage vs. Case Temperature

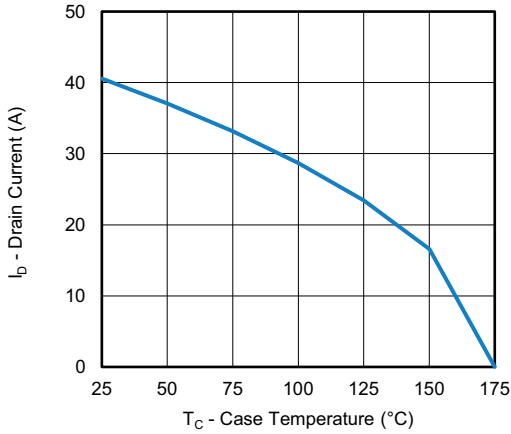

Fig. 13 - Drain Current vs. Case Temperature

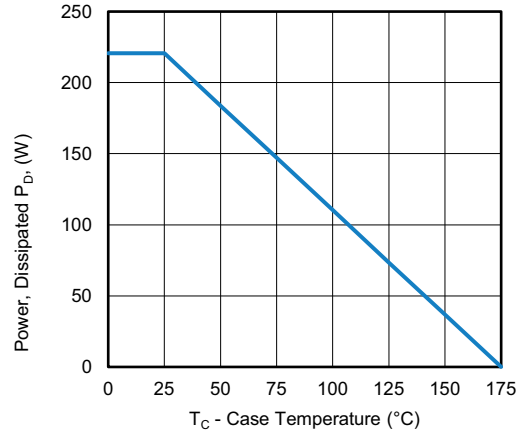

Fig. 15 - Power, Dissipated P_D vs. Case Temperature

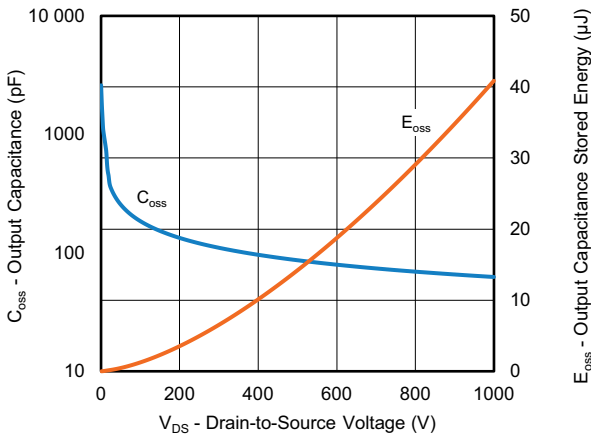

Fig. 14 - Output Capacitance and its Stored Energy vs. Drain-to-Source Voltage

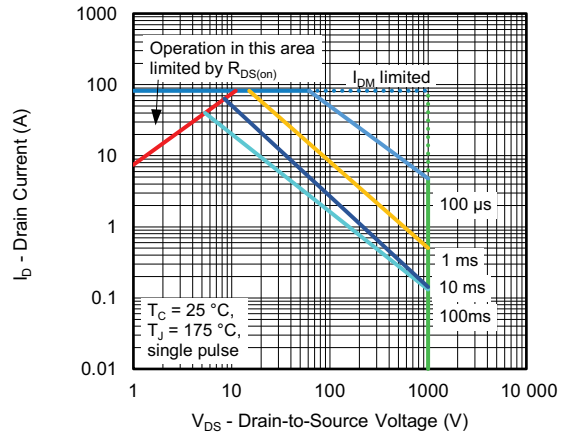

Fig. 16 - Safe Operating Area

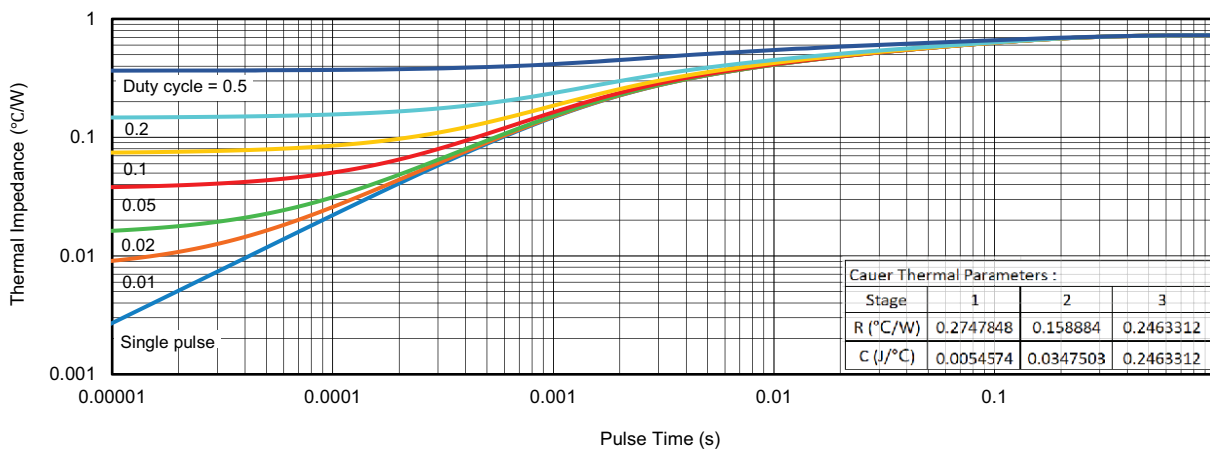

Fig. 17 - Transient Thermal Impedance

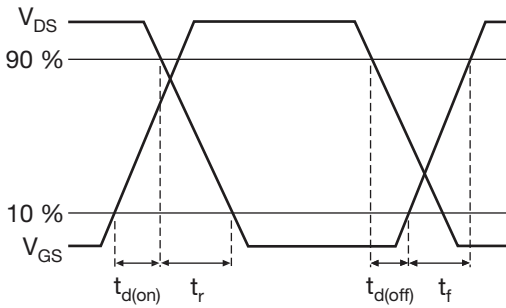

Fig. 18 - Waveforms of Switching Time

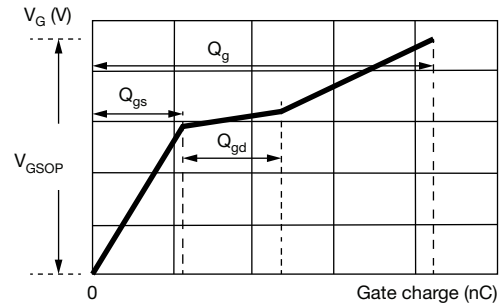

Fig. 21 - Waveforms for Gate Charge

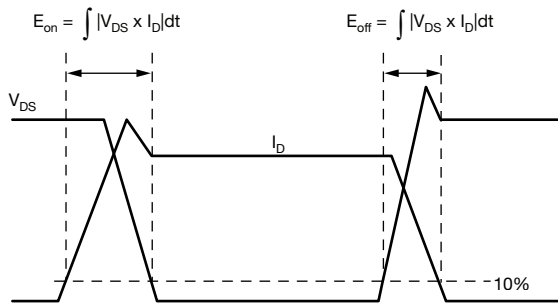

Fig. 19 - Waveforms for Switching Energy

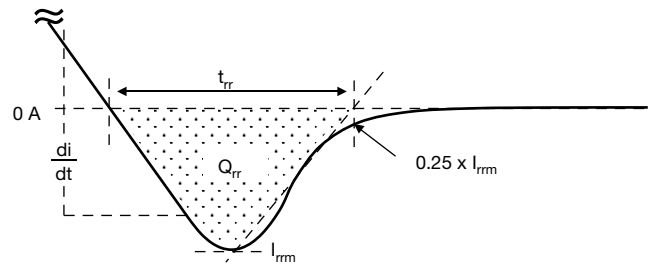

Fig. 22 - Waveforms for Reverse Recovery

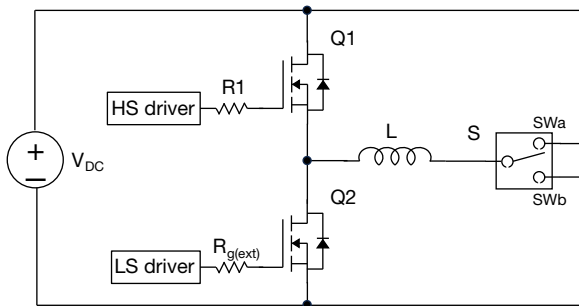

Fig. 20 - Switching and Reverse Diode Characteristics Measurement Circuit

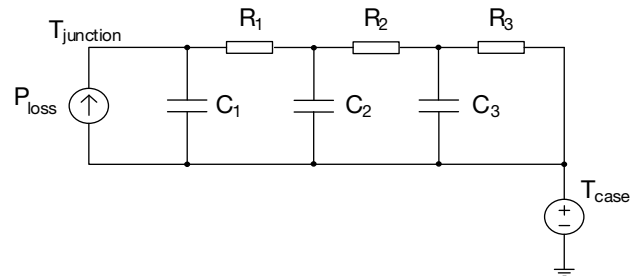

Fig. 23 - Thermal Equivalent Circuit

Vishay Siliconix maintains worldwide manufacturing capability. Products may be manufactured at one of several qualified locations. Reliability data for Silicon Technology and Package Reliability represent a composite of all qualified locations. For related documents such as package / tape drawings, part marking, and reliability data, see www.vishay.com/ppg?92859.



Case Outline for TO-263 7L Package

FACILITY CODE: 9

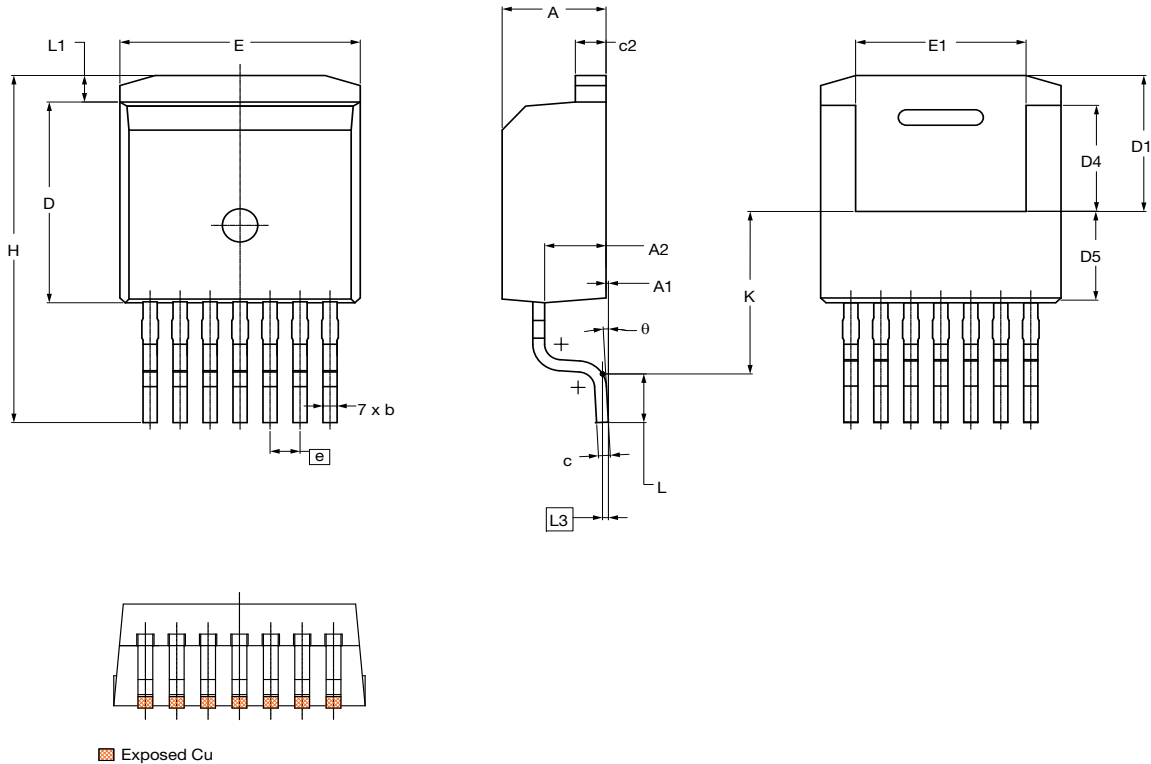

DIM.	MILLIMETERS		
	MIN.	NOM.	MAX.
A	4.30	4.40	4.50
A1	0.00	0.10	0.25
A2	2.45	2.60	2.75
b	0.50	0.60	0.70
c	0.45	0.50	0.60
c2	1.20	1.30	1.40
D	8.93	9.08	9.23
D1	6.15 ref.		
D4	4.65	4.80	4.95
D5	3.83	4.13	4.43
E	10.08	10.18	10.28
E1	6.82	7.22	7.62
e	1.27 BSC.		
H	15.00	15.70	16.00
K	7.30		
L	1.90	2.20	2.50
L1	1.00	1.20	1.40
L3	0.25 BSC.		
θ	0 °	3 °	7 °

ECN: S25-0851-Rev. C, 18-Jul-2025
DWG: 6119

Notes

- All dimensions are in mm and angles are in degrees
- Dimension D and E do not include mold flash. These dimensions are measured at the outermost extreme of the plastic body
- Thermal pad contour optional within Dimensions E, L1, D4 and E1
- Dimension D4 and E1 establish a minimum mounting surface for the thermal pad
- There is exposed Cu and molding flash bleeding at the pin which is close to package



Disclaimer

ALL PRODUCT, PRODUCT SPECIFICATIONS AND DATA ARE SUBJECT TO CHANGE WITHOUT NOTICE TO IMPROVE RELIABILITY, FUNCTION OR DESIGN OR OTHERWISE.

Vishay Intertechnology, Inc., its affiliates, agents, and employees, and all persons acting on its or their behalf (collectively, "Vishay"), disclaim any and all liability for any errors, inaccuracies or incompleteness contained in any datasheet or in any other disclosure relating to any product.

Vishay makes no warranty, representation or guarantee regarding the suitability of the products for any particular purpose or the continuing production of any product. To the maximum extent permitted by applicable law, Vishay disclaims (i) any and all liability arising out of the application or use of any product, (ii) any and all liability, including without limitation special, consequential or incidental damages, and (iii) any and all implied warranties, including warranties of fitness for particular purpose, non-infringement and merchantability.

Statements regarding the suitability of products for certain types of applications are based on Vishay's knowledge of typical requirements that are often placed on Vishay products in generic applications. Such statements are not binding statements about the suitability of products for a particular application. It is the customer's responsibility to validate that a particular product with the properties described in the product specification is suitable for use in a particular application. Parameters provided in datasheets and / or specifications may vary in different applications and performance may vary over time. All operating parameters, including typical parameters, must be validated for each customer application by the customer's technical experts. Product specifications do not expand or otherwise modify Vishay's terms and conditions of purchase, including but not limited to the warranty expressed therein.

Hyperlinks included in this datasheet may direct users to third-party websites. These links are provided as a convenience and for informational purposes only. Inclusion of these hyperlinks does not constitute an endorsement or an approval by Vishay of any of the products, services or opinions of the corporation, organization or individual associated with the third-party website. Vishay disclaims any and all liability and bears no responsibility for the accuracy, legality or content of the third-party website or for that of subsequent links.

Vishay products are not designed for use in life-saving or life-sustaining applications or any application in which the failure of the Vishay product could result in personal injury or death unless specifically qualified in writing by Vishay. Customers using or selling Vishay products not expressly indicated for use in such applications do so at their own risk. Please contact authorized Vishay personnel to obtain written terms and conditions regarding products designed for such applications.

No license, express or implied, by estoppel or otherwise, to any intellectual property rights is granted by this document or by any conduct of Vishay. Product names and markings noted herein may be trademarks of their respective owners.