

## LTE IoT 24 Click



PID: MIKROE-6933

**LTE IoT 24 Click** is a compact add-on board designed for low-power LTE-M and NB-IoT cellular connectivity for IoT and M2M applications. It is based on the ME310G1-WW ([ME310G1WW06T070400](#)) module from [Telit Cinterion](#). This module features dual-mode LTE-M/NB-IoT operation, global band support, UART and SPI communication interfaces, USB Type-C firmware upgrade capability, 1.8V uSIM card support, as well as additional test points for AUX UART, DVI, antenna tuning, and GPIO access, making it a flexible and well-equipped solution for modern connected devices. It is suitable for telematics services, vehicle tracking, road pricing systems, pay-as-you-drive insurance solutions, internet connectivity, and other secure low-power wide-area IoT applications.

For more information about **LTE IoT 24 Click** visit the official [product page](#).

### How does it work?

LTE IoT 24 Click is based on the ME310G1-WW (ME310G1WW06T070400), a worldwide LTE Cat M1/NB2 communication module from Telit Cinterion, developed for a wide range of IoT and M2M applications. Supporting dual-mode LTE-M and NB-IoT operation, the ME310G1-WW provides flexibility by allowing developers to target different low-power wide-area network infrastructures depending on regional and operator requirements. It covers a wide frequency range of 850, 900, 1800, and 1900MHz, while offering extensive LTE Cat M1 band support including B1, B2, B3, B4, B5, B8, B12, B13, B18, B19, B20, B25, B26, B27, B28, B66, and B85, as well as NB-IoT band support including B1, B2, B3, B4, B5, B8, B12, B13, B18, B19, B20, B25, B26, B28, B66, B71, and B85. The module delivers an LTE output power of 23dBm in Power Class 3 and GSM/GPRS output power of 33dBm in Power Class 4, ensuring dependable wireless performance for demanding remote communication scenarios. The LTE IoT 24 Click is ideal for

Mikroe produces entire development toolchains for all major microcontroller architectures.

Committed to excellency, we are dedicated to helping engineers bring the project development up to speed and achieve outstanding results.



ISO 27001: 2013 certification of informational security management system.  
 ISO 14001: 2015 certification of environmental management system.  
 OHSAS 18001: 2008 certification of occupational health and safety management system.



ISO 9001: 2015 certification of quality management system (QMS).

secure telematics and connected services where tamper-resistance, confidentiality, integrity, and authenticity of end-user information are important, including telematics services, road pricing systems, pay-as-you-drive insurance solutions, vehicle tracking, and internet connectivity applications.

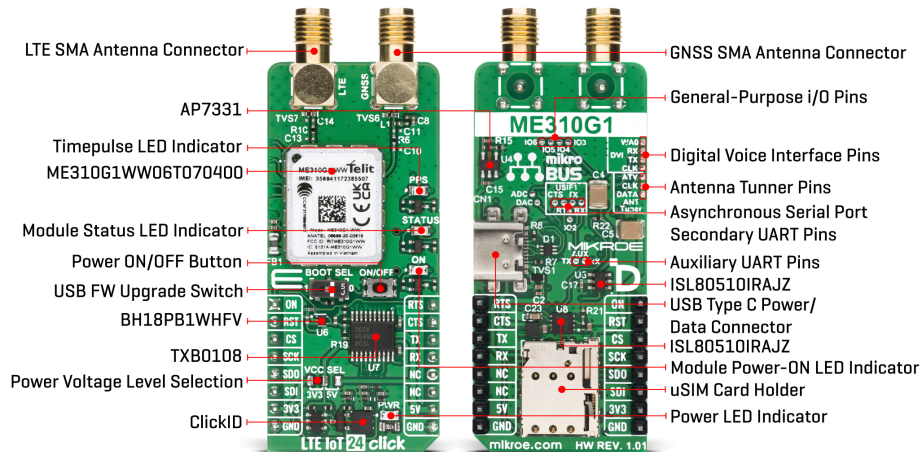

Communication between the ME310G1-WW and the host MCU is made through a UART interface, using standard UART RX and TX pins and hardware flow control pins (CTS/RTS - Clear to Send/Ready to Send). The module defaults to a communication speed of 115200bps, allowing for data exchange over AT commands. The board also supports SPI in addition to the UART interface, and features a USB Type-C connector for module firmware upgrade (integrated universal serial bus (USB 2.0 HS) transceiver). Also, there is also a USB FW upgrade switch labeled BOOT SEL to manage firmware upgrades. This switch has positions 0 for normal operation and 1 for firmware upgrades over USB, ensuring a straightforward upgrade process.

LTE IoT 24 Click is additionally equipped with several onboard features that enhance its usability in cellular and positioning applications. The board provides two SMA connectors intended for LTE antennas, such as the LTE Flat Rotation Antenna, as well as one SMA connector for a GNSS antenna, including solutions such as the GPS Active Antenna both offered by MIKROE. For simplified power management, the board includes an ON/OFF button that allows the user to manually power the module on or off, while the same function can also be controlled digitally through the ON pin of the mikroBUS™ socket. A green ON LED indicates when the module is powered on, giving immediate visual confirmation of its operating state.

In addition, the board is equipped with a micro SIM card holder that supports only 1.8V uSIM cards, matching the module's low-voltage design requirements. A blue STATUS LED is used to indicate the module status, clearly distinguishing between power-off or deep-sleep mode and idle, active, or connected operation. For applications that rely on accurate timing, a yellow PPS LED displays the timepulse signal, providing precise visual indication of synchronization activity.

The back side of LTE IoT 24 Click exposes several test points that provide access to additional module functionality. These test points include the USIF1 Secondary UART pins, which are currently not supported and are reserved for future use, allowing possible interface expansion in upcoming implementations. Also available are the AUX UART pins, which provide access to the module's auxiliary UART interface operating with 1.8V CMOS logic levels. The board further exposes antenna tuner pins, enabling dynamic antenna tuning across multiple frequencies and giving developers greater flexibility when optimizing RF performance.

Mikroe produces entire development toolchains for all major microcontroller architectures.

Committed to excellency, we are dedicated to helping engineers bring the project development up to speed and achieve outstanding results.



ISO 27001: 2013 certification of informational security management system.  
 ISO 14001: 2015 certification of environmental management system.  
 OHSAS 18001: 2008 certification of occupational health and safety management system.



ISO 9001: 2015 certification of quality management system (QMS).

In addition, Digital Voice Interface pins are available, with the DVI based on the I2S serial bus interface. This allows the audio port to be connected to a digital interface using multiple compliant codecs whenever analog audio functionality is required. Alongside these interfaces, four GPIO test points are also provided, offering extra programmable digital control lines for application-specific use and further customization.

This Click board™ can operate with both 3.3V and 5V logic voltage levels selected via the VCC SEL jumper. Since the ME310G1-WW module operates at 3.8V and communicates at 1.8V, a logic-level translator, the [TXB0108](#) is also used for proper operation and an accurate signal-level translation. This way, both 3.3V and 5V capable MCUs can use the communication lines properly. Also, this Click board™ comes equipped with a library containing easy-to-use functions and an example code that can be used as a reference for further development.

## Specifications

|                  |   |
|------------------|---|
| Type             | LTE IoT   |
| Applications     | Ideal for telematics services, vehicle tracking, road pricing systems, pay-as-you-drive insurance solutions, internet connectivity, and other secure low-power wide-area IoT applications |
| On-board modules | ME310G1WW06T070400 - LTE Cat M1/NB2 communication module from Telit Cinterion   |
| Key Features     | Worldwide LTE Cat M1/NB2 connectivity, UART and SPI communication interface support, USB Type-C connector for firmware upgrade, micro SIM card holder with 1.8V uSIM support, and more    |
| Interface        | SPI, UART, USB  |
| Feature          | ClickID   |
| Compatibility    | mikroBUS™   |
| Click board size | L (57.15 x 25.4 mm)   |
| Input Voltage    | 3.3V or 5V, External  |

## Pinout diagram

This table shows how the pinout on LTE IoT 24 Click corresponds to the pinout on the mikroBUS™ socket (the latter shown in the two middle columns).

| Notes                | Pin         |  |      |     |    | Pin        | Notes        |
|----------------------|-------------|---|------|-----|----|------------|--------------|
| Module Power-ON      | <b>ON</b>   | 1   | AN   | PWM | 16 | <b>RST</b> | UART RTS     |
| ID SEL               | <b>RST</b>  | 2   | RST  | INT | 15 | <b>CTS</b> | UART CTS     |
| SPI Select / ID COMM | <b>CS</b>   | 3   | CS   | RX  | 14 | <b>TX</b>  | UART TX      |
| SPI Clock            | <b>SCK</b>  | 4   | SCK  | TX  | 13 | <b>RX</b>  | UART RX      |
| SPI Data OUT         | <b>SDO</b>  | 5   | MISO | SCL | 12 | NC         |              |
| SPI Data IN          | <b>SDI</b>  | 6   | MOSI | SDA | 11 | NC         |              |
| Power Supply         | <b>3.3V</b> | 7   | 3.3V | 5V  | 10 | <b>5V</b>  | Power Supply |
| Ground               | <b>GND</b>  | 8   | GND  | GND | 9  | <b>GND</b> | Ground       |

Mikroe produces entire development toolchains for all major microcontroller architectures.

Committed to excellency, we are dedicated to helping engineers bring the project development up to speed and achieve outstanding results.



ISO 27001: 2013 certification of informational security management system.  
 ISO 14001: 2015 certification of environmental management system.  
 OHSAS 18001: 2008 certification of occupational health and safety management system.



ISO 9001: 2015 certification of quality management system (QMS).

## Onboard settings and indicators

| Label | Name     | Default | Description  |
|-------|----------|---------|--|
| LD1   | PWR      | -       | Power LED Indicator  |
| LD2   | PPS      | -       | Timepulse LED Indicator  |
| LD3   | STATUS   | -       | Module Status LED Indicator  |
| LD4   | ON       | -       | Module Power-ON LED Indicator  |
| JP1   | VCC SEL  | Left    | Power Voltage Level Selection 3V3/5V: Left position 3V3, Right position 5V |
| SW1   | BOOT SEL | Right   | USB FW Upgrade Selection 1/0: Left position 1, Right position 0            |
| T1    | ON/OFF   | -       | Power ON/OFF Button  |

## LTE IoT 24 Click electrical specifications

| Description       | Min   | Typ | Max    | Unit |
|-------------------|-------|-----|--------|------|
| Supply Voltage    | 3.3   | -   | 5      | V    |
| Frequency Range   | 850   | -   | 1900   | MHz  |
| RX Sensitivity    | -99.3 | -   | -116.8 | dBm  |
| RF Transmit Power | 20    | -   | 32.5   | dBm  |

## Software Support

[LTE IoT 24 Click](#) demo application is developed using the [NECTO Studio](#), ensuring compatibility with [mikroSDK](#)'s open-source libraries and tools. Designed for plug-and-play implementation and testing, the demo is fully compatible with all development, starter, and mikromedia boards featuring a [mikroBUS™](#) socket.

## Example Description

Application example shows device capability of connecting to the network and sending SMS or TCP/UDP messages or retrieving data from GNSS using standard "AT" commands.

## Key Functions

- `Iteiot24_cfg_setup` This function initializes Click configuration structure to initial values.
- `Iteiot24_init` This function initializes all necessary pins and peripherals used for this Click board.
- `Iteiot24_set_sim_apn` This function sets APN for sim card.
- `Iteiot24_send_sms_text` This function sends text message to a phone number.
- `Iteiot24_cmd_run` This function sends a specified command to the Click module.

## Application Init

Initializes the driver and logger.

Mikroe produces entire development toolchains for all major microcontroller architectures.

Committed to excellency, we are dedicated to helping engineers bring the project development up to speed and achieve outstanding results.



ISO 27001: 2013 certification of informational security management system.  
ISO 14001: 2015 certification of environmental management system.  
OHSAS 18001: 2008 certification of occupational health and safety management system.



ISO 9001: 2015 certification of quality management system (QMS).

## Application Task

Application task is split in few stages:

- **LTEIOT24\_POWER\_UP:**  
Powers up the device, performs a factory reset and reads system information.
- **LTEIOT24\_CONFIG\_CONNECTION:**  
Sets configuration to device to be able to connect to the network (used only for SMS or TCP/UDP demo examples).
- **LTEIOT24\_CHECK\_CONNECTION:**  
Waits for the network registration indicated via CREG command and then checks the signal quality report (used only for SMS or TCP/UDP demo examples).
- **LTEIOT24\_CONFIG\_EXAMPLE:**  
Configures device for the selected example.
- **LTEIOT24\_EXAMPLE:**  
Depending on the selected demo example, it sends an SMS message (in PDU or TXT mode) or TCP/UDP message, or waits for the GPS fix to retrieve location info from GNSS. By default, the TCP/UDP example is selected.

## Application Output

This Click board can be interfaced and monitored in two ways:

- Application Output - Use the "Application Output" window in Debug mode for real-time data monitoring. Set it up properly by following [this tutorial](#).
- UART Terminal - Monitor data via the UART Terminal using a [USB to UART converter](#). For detailed instructions, check out [this tutorial](#).

## Additional Notes and Information

The complete application code and a ready-to-use project are available through the NECTO Studio Package Manager for direct installation in the [NECTO Studio](#). The application code can also be found on the MIKROE [GitHub](#) account.

## Resources

[mikroBUS™](#)

[mikroSDK](#)

Mikroe produces entire development toolchains for all major microcontroller architectures.

Committed to excellency, we are dedicated to helping engineers bring the project development up to speed and achieve outstanding results.



ISO 27001: 2013 certification of informational security management system.  
ISO 14001: 2015 certification of environmental management system.  
OHSAS 18001: 2008 certification of occupational health and safety management system.



ISO 9001: 2015 certification of quality management system (QMS).

[Click board™ Catalog](#)

[Click boards™](#)

[ClickID](#)

## Downloads

[LTE IoT 24 click example package](#)

[LTE IoT 24 click 2D and 3D files v101](#)

[LTE IoT 24 click schematic v101](#)

[ME310G1-WW datasheet](#)

Mikroe produces entire development toolchains for all major microcontroller architectures.

Committed to excellency, we are dedicated to helping engineers bring the project development up to speed and achieve outstanding results.



ISO 27001: 2013 certification of informational security management system.  
ISO 14001: 2015 certification of environmental management system.  
OHSAS 18001: 2008 certification of occupational health and safety management system.



ISO 9001: 2015 certification of quality management system (QMS).