



Brand of NTN Group

Technical data

SUCP210N

Bearing units



Stainless steel cast housing, stainless steel insert ball bearing with socket set screws, seal with slinger, food grease

KIT CONTENT

SUC210, SP210N

VISUAL (S)

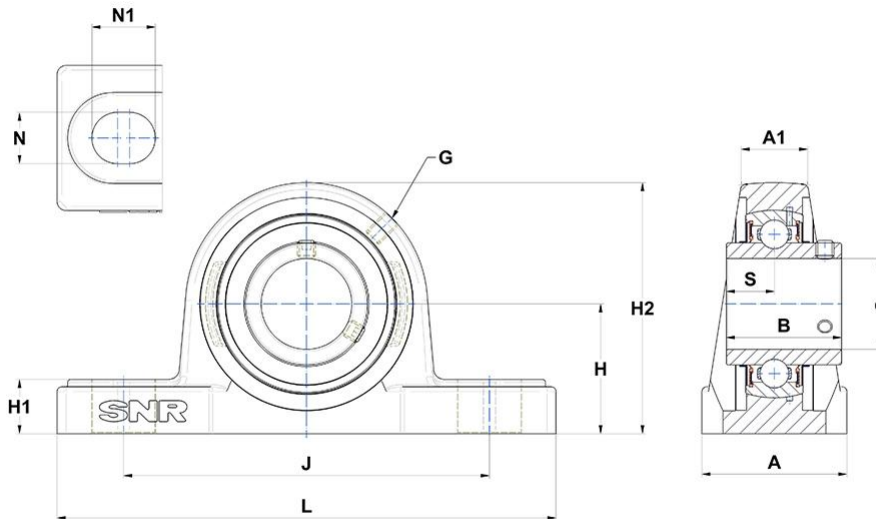

PRODUCT DEFINITION

Brand	SNR
A - Housing width	60 mm
A1 - Housing top width	30 mm
B - Width of Inner Ring	51,6 mm
d - Shaft diameter	50 mm



NTN Europe

1 rue des Usines · BP 2017 · 74010 Annecy Cedex · France · Tel. +33 (0)4 50 65 30 00
S.A. au capital de 322 639 919 € · RCS ANNECY B 325 821 072 · Id. Fiscale : FR 48 325 821 072
SIRET 325 821 072 00015 · Code APE 2815 Z · Code NACE 28.15

PRODUCT DEFINITION

G - Grease fitting	M6x1
H - Distance mounting base to centerline spheric. seating diam.	57,2 mm
H1 - Housing foot height	22 mm
H2 - Housing height	114 mm
J - Mounting holes distance	159 mm
L - Housing length	206 mm
N - Mounting hole dimension	20 mm
N1 - Mounting hole length	25 mm
S - Distance front side/bearing centre	19 mm

PRODUCT PERFORMANCE

C - Dynamic load rating	35000000 mN
C0 - Static load rating	23100000 mN
Operating temperature min.	253,15 °K
Operating temperature max.	373,15 °K

OTHER FEATURES

Mass	3,25 kg
Recommended tightening torque for set screw	18.7 N-m

