

EPX Electronic Panel Convector Heaters

Dimensions

(millimetres)

Model(s)	Watt	A	B	X
EPX 500	0.5kW	450	108	116
EPX 750	0.75kW	620	108	286
EPX 1000	1.0kW	620	108	286
EPX 1250	1.25kW	688	108	354
EPX 1500	1.5kW	688	108	354
EPX 2000	2.0kW	860	108	524

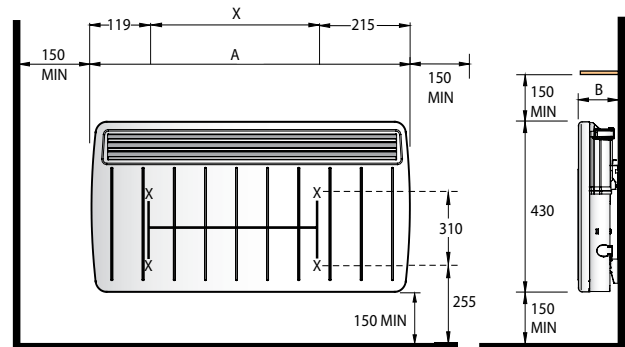

Fig. 1

IMPORTANT: THESE INSTRUCTIONS SHOULD BE READ CAREFULLY AND RETAINED FOR FUTURE REFERENCE

Important Safety Advice

When using electrical appliances, basic precautions should always be followed to reduce the risk of fire, electrical shock, and injury to persons, including the following:

IMPORTANT – The wall bracket supplied with the appliance must be used.

WARNING – DO NOT USE THIS HEATER IN THE IMMEDIATE SURROUNDINGS OF A BATH, A SHOWER OR A SWIMMING POOL.

IMPORTANT – If the heater is installed in a room containing a bath or shower, it must be so installed that switches and other controls cannot be touched by a person using a bath or shower.

Do not use outdoors.

Do not locate the heater immediately below a fixed socket outlet or connection box.

WARNING: In order to avoid overheating, do not cover the heater. Do not place material or garments on the heater, or obstruct the air circulation around the heater, for instance by curtains or furniture, as this could cause overheating and a fire risk.

NEVER cover or obstruct in any way the heat outlet slots at the top of the heater or the air inlet slots in the base of the heater.

 The heater carries the Warning symbol indicating that it must not be covered.

CAUTION - Some parts of this product can become very hot and cause burns. Particular attention has to be given where children and vulnerable people are present. This appliance can be used by children aged from 8 years and above and by persons with reduced physical, sensory or mental capabilities or lack of experience and knowledge if they have been given supervision or instruction concerning use of the appliance in a safe way and understand

the hazards involved.

Children shall not play with the appliance. Cleaning and user maintenance shall not be made by children without supervision.

Children of less than 3 years should be kept away unless continuously supervised.

Children aged from 3 years and less than 8 years shall only switch on/off the appliance provided that it has been placed or installed in its intended normal operating position and they have been given supervision or instruction concerning use of the appliance in a safe way and understand the hazards involved. Children aged from 3 years and less than 8 years shall not plug in, regulate and clean the appliance or perform user maintenance.

Note that due care and consideration must be taken when using this heater in series with a thermal control, a program controller, a timer or any other device that switches on the heat automatically, since a fire risk exists when the heater is accidentally covered or displaced.

If the supply cord is damaged it must be replaced by the manufacturer or service agent or a similarly qualified person in order to avoid a hazard.

WARNING: Servicing and product repairs should only be undertaken by the manufacturers approved service agent or a similarly qualified person, using only exact manufacturer approved spare parts.

A means for disconnection must be incorporated in the fixed wiring of the premises in accordance with the wiring rules. The supply circuit to the heater must incorporate a double pole isolating switch having a contact separation of at least 3mm.

Electrical

WARNING – THIS APPLIANCE MUST BE EARTHED

The electrical installation must be carried out by a competent electrician, and be in strict accordance with the current I.E.E. regulations for Electrical Equipment in Buildings.

The wires in this mains lead are coloured in accordance with the following code:

GREEN AND YELLOW :	EARTH
BLUE :	NEUTRAL
BROWN :	LIVE
BLACK :	PILOT WIRE

- see also 'Pilot Wire Connection'.

The heater is fitted with a length of flexible cable type H05VV-F size 4 x 1.0mm² for connection to the fixed wiring of the premises through a suitable connection box positioned adjacent to the heater.

The supply circuit to the heater must incorporate a double pole isolating switch having a contact separation of at least 3mm.

Pilot Wire Connection

The BLACK control wire is designed to carry a signal from slot in or wall mounted Dimplex programmers. If, however a programmer is not being used, the pilot wire should be isolated in accordance with the current IEE Wiring Regulations.

IMPORTANT - DO NOT connect the BLACK pilot wire to earth. Care should be taken with the installation of the pilot wire(s) as when switching to background (set back) they become energised at 240V although only at a current of less than 100mA. In every case a suitable means of isolation must be provided for the pilot wire and marked to indicate that two sources of supply may be present at the heater.

Where pilot wires are installed separately from the heater final sub-circuit they should be protected, double insulated and carry their own integral earth continuity conductor.

Supplementary Earth Bonding

Should Equipotential Earth Bonding be required the earthing conductor in the supply cord is deemed to provide the supplementary bonding connection (see Regulation 544.2.5, 17th Edition I.E.E. Wiring Regulations).

General

The EPX Convector is designed for wall mounting on the wall brackets supplied. It should only be operated when in the upright position as shown.

All models are splashproof to IPX4 standard.

Before connecting the heater check that the supply voltage is the same as that stated on the heater.

NOTE - Lit cigarettes, candles and oil burners, combined with the convection effect of electric heaters can cause soot deposits to build up on the surface directly above and to the sides of the heater. This is not a fault of the heater. Extensive burning of candles or smoking in the operating environment of this product can produce heavy discolouration within a few months of use.

Wall Mounting

IMPORTANT – The wall brackets supplied with the appliance must be used. The heater should be positioned observing the minimum clearances stated around the heater - see **Fig. 1**.

DO NOT locate the heater immediately below a fixed socket outlet or connection box.

1. Remove wall mounting bracket from the back of the heater by depressing the spring latch at the top of each bracket - see **Fig. 2**.
2. Fix the wall bracket securely to the wall through the four screw holes provided.
3. Present the heater to the wall bracket, and engage lower slots in the back with bracket.
4. Raise the heater to upright position and push the heater onto brackets to engage top latch.

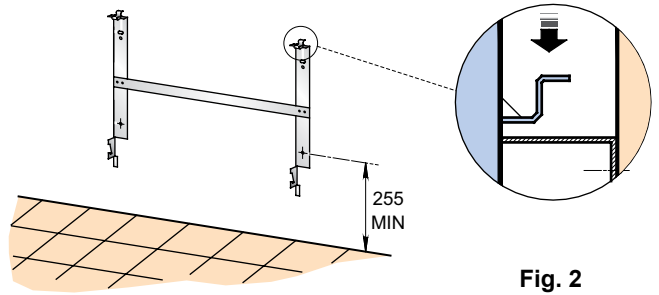





Fig. 2

Operation

Switching On the Heater (see Fig. 3)

The button marked  controls the electricity supply to the electronic thermostat. An indicator beside the  button shows when the unit is powered 'ON'.

Setting Desired Temperature (see Fig. 3)

The heater is fitted with an adjustable thermostat enabling the room temperature to be controlled by adjusting the slider accordingly. The min setting  represents a room temperature of approximately 5°C and may be used for protection against frost. The 'MAX' setting represents a room temperature of approximately 30°C. The  symbol glows when the elements are actually heating.

Turn on the heater using the  button and move the thermostat slider to the desired position. When the room temperature has reached the desired level, the power to the elements will be reduced, the heater will then maintain the room temperature at the chosen level.

NOTE - Should your heater fail to come on when the thermostat slider is at a low setting, this may be due to the room temperature being higher than the thermostat setting.

Background Temperature

When used in conjunction with a remote programming device supporting a background/setback setting, the heater will automatically operate at a room temperature setting of 5°C less than the thermostat setting when the programme is in background/setback mode.

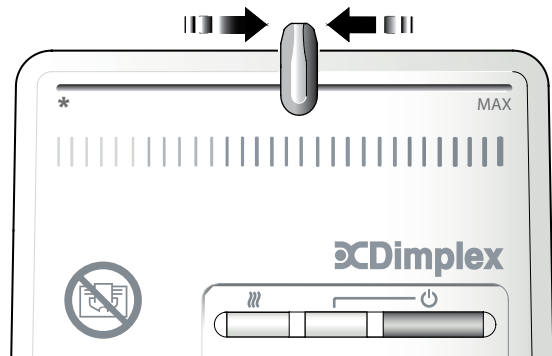

Fig. 3

Limiting the thermostat setting

Before wall mounting the product the installer may wish to limit the heat selection slider movement for the operator. This may be achieved by removing the two plastic pins (see 'x' in **Fig. 4**) from the rear of the thermostat moulding using pliers and inserting them in the preferred holes to limit the slider movement.

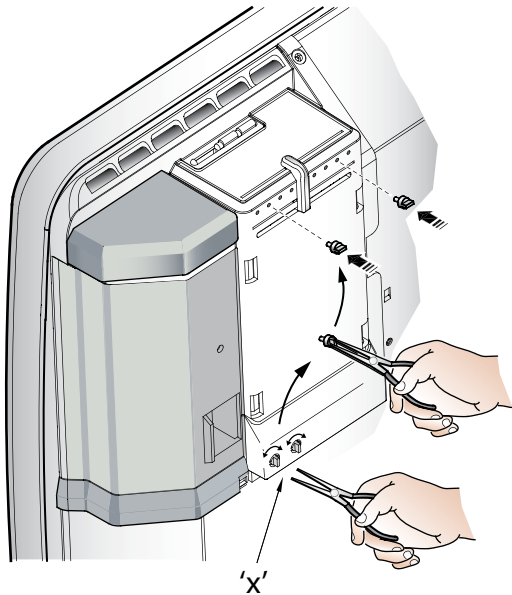



Fig. 4

Notes to the Installer

Test Mode

When the EPX panel heater is connected via a pilot wire system, the test mode allows the installer to check whether the heater is responding correctly to the incoming pilot wire signal.

Before switching the heater on at the mains, place the thermostat slider in the 'MAX' position, then press and hold the  button whilst switching on the mains.

The unit will now enter a test state for four mins. During this test state the  neon will indicate the pilot wire status:

NEON	PILOT WIRE CONTROLLER MODE
Neon on -	ON
Neon off -	OFF
Neon flashing fast approx every 0.1sec -	FROST
Neon flashing slow approx every 0.5 sec -	SETBACK

Accessory Modules

Optional accessory modules are available for use with EPX range of panel heaters - see separate User Instructions for details on the operation of each accessory module.

Before fitting a control module switch the heater off at the mains supply.

To insert a module, the plug-in protective cover on the right hand side of the thermostat unit at the top of the heater must first be removed.

Insert a flat-head screwdriver into the side of the cover and prise away from the heater - see Fig. 5.

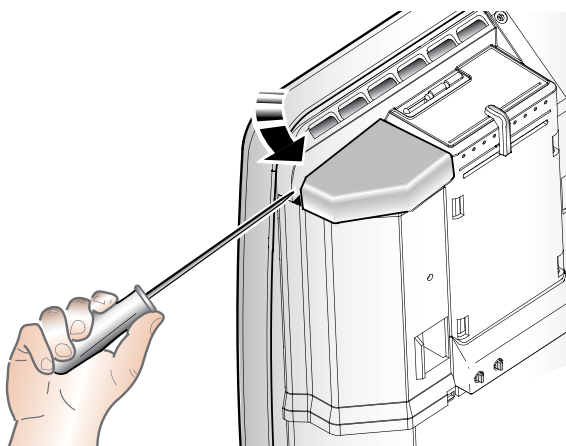

Fig. 5

Lift the cover away from the heater (see Fig. 6) to reveal the slide in compartment.

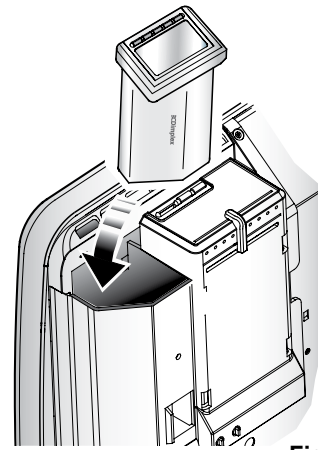

Fig. 7

Insert the accessory module into the slot ensuring it is positively located in position - see Fig. 7. Switch the heater on at the mains supply.

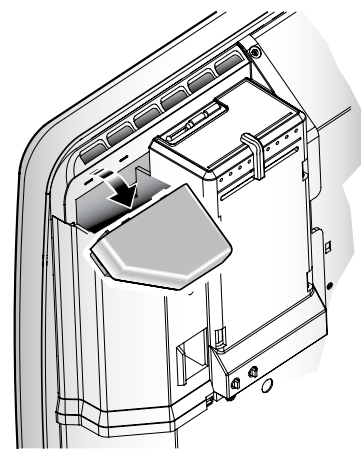

Fig. 6

Cleaning

WARNING – ALWAYS DISCONNECT FROM THE POWER SUPPLY BEFORE CLEANING THE HEATER.

Before commencing cleaning, unplug the heater and allow it to cool. Disconnect the electricity supply to the appliance.

The outside can be cleaned by wiping it over with a soft damp cloth and then dried. Do not use abrasive cleaning powders or furniture polish, as this can damage the surface finish.

To release heater from the wall bracket for cleaning or redecoration, depress latch on both brackets (see Fig. 2) and hinge forward.

Recycling

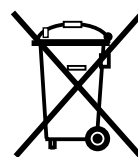

For electrical products sold within the European Community.

At the end of the electrical products useful life it should not be disposed of with household waste. Please recycle where facilities exist. Check with your Local Authority or retailer for recycling advice in your country.

After Sales Service

If this product appears damaged when first received or does not function correctly contact us by email aftersales@dimplex.co.uk or call 0844 879 3588 and we will be able to help. For ROI please call 01 842 8222.

Do Not Return the product in the first instance as this may delay us providing you with a satisfactory service.

ACCIDENTAL DAMAGE IS NOT COVERED UNDER THE WARRANTY.

Your product is guaranteed for two years from date of purchase. Within this period we undertake to repair this product free of charge provided it has been installed and operated in accordance with these instructions. Should you require assistance with this product please go to www.dimplex.co.uk and click on "Customer Support" or email us at aftersales@dimplex.co.uk

Alternatively call our contact centre on 0844 879 3588 (UK only). This is a Lo-call no. from a BT landline - other providers including mobile phones may charge you more. For ROI please call 01 842 8222.

To assist you, we will need the following information: model no and serial no (these can be found on the product), nature of the fault and date of purchase. **Please retain your receipt as proof of purchase.** Your rights under this guarantee are additional to your statutory rights, which in turn are not affected by this guarantee.

Spares can be purchased online, go to www.dimplex.co.uk/outlet_store

Energy Saving Tips

The energy we use to heat, light and power our homes contributes over a quarter of the UK's carbon emissions, the principle contributor to climate change.

Around half the energy used in the home is for heating and hot water, so using your heating system efficiently will not only help the environment, but also save you money!

Energy efficiency tips for heating and hot water

1. Don't set the temperature too high...

By reducing the thermostat setting by just 1°C can reduce your energy use by as much as 10%. And if you're going away for the winter, leave the thermostat on the frost protection setting to provide protection from freezing at a minimum cost.

2. Use it where you need it...

Set the appropriate temperature on your heaters for the room they are in; for example, leave the thermostat on a heater in a spare bedroom on a lower setting.

3. Use it when you need it...

Use heaters fitted with timers or linked to central controllers to turn the heating on only when you need it and automatically switch it off when you don't.

4. Curtains...

Close your curtains at dusk to stop heat escaping through the windows.

5. Windows...

Nearly 25% of heat loss can occur through poorly insulated frames and single glazing. If you can't afford to double glaze all your windows, go for the rooms you heat most.

6. Treat your hot water tank... give it a jacket

An insulating jacket for hot water tanks only costs a few pounds and pays for itself within months. Fit one that's at least 75mm (3") thick and you could save £10-£15 a year.

7. Water...

Use a shower if you have one to save time, money and water.

Don't set the thermostat too high on your water heater - 60°C/140°F is usually adequate for bathing and washing.

Put the plug in when running hot water in your sink - leaving hot taps running is both wasteful and expensive.

Ensure dripping taps are repaired quickly. In just one day, you could waste enough water to fill a bath.

Other Energy Saving Tips for Around the Home

1. Lights

Turn off lights whenever you leave a room for more than ten minutes.

Use low-energy bulbs wherever you can as they use less than a quarter of the electricity used by ordinary light bulbs and last ten times longer!

2. Cooking

Use the right size pan for the food and cooker hob.

Keep saucepan lids on - this enables you to turn down the heat.

Boil water for cooking in a kettle.



The product complies with the European Safety Standards EN60335-2-30 and the European Standard Electromagnetic Compatibility (EMC) EN55014, EN60555-2 and EN60555-3. These cover the essential requirements of EEC Directives 2006/95/EC and 2004/108/EC

DIMPLEX
MILLBROOK HOUSE
GRANGE DRIVE
HEDGE END
SOUTHAMPTON
SO30 2DF

TEL: 0844 879 3588

WEBSITE: www.dimplex.co.uk

Republic of Ireland Tel. 01 8428222

[c] GDC Group Ltd,

All rights reserved. Material contained in this publication may not be reproduced in whole or in part, without prior permission in writing of Dimplex.
A division of GDC Group Ltd,