

5 4 3 2 1

Mating face according to : MIL-C-24308 / DIN 41652 / CECC 75301-802

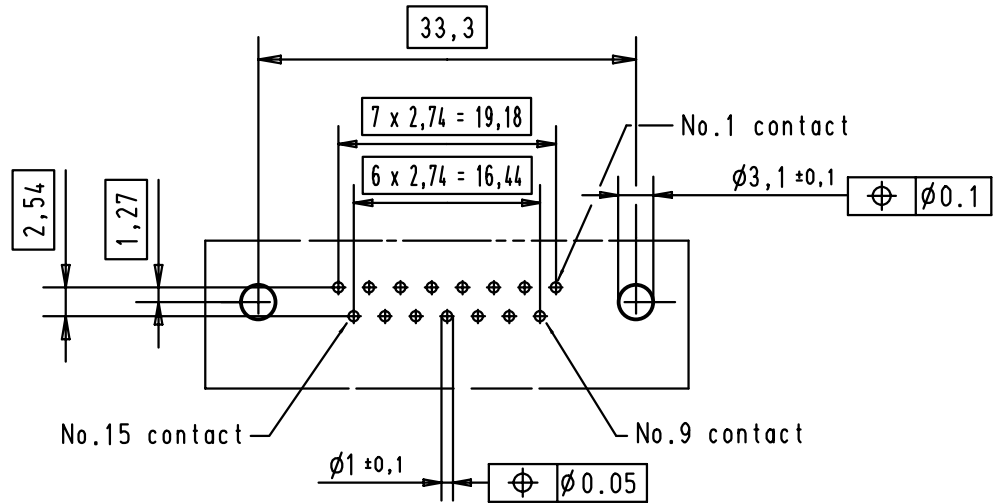
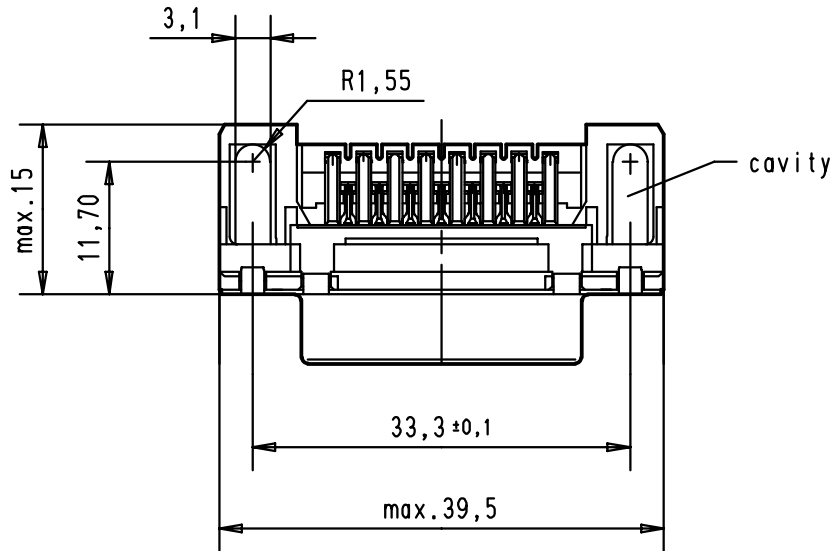
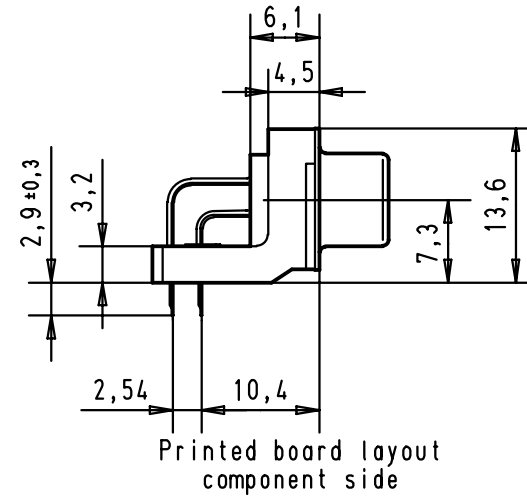
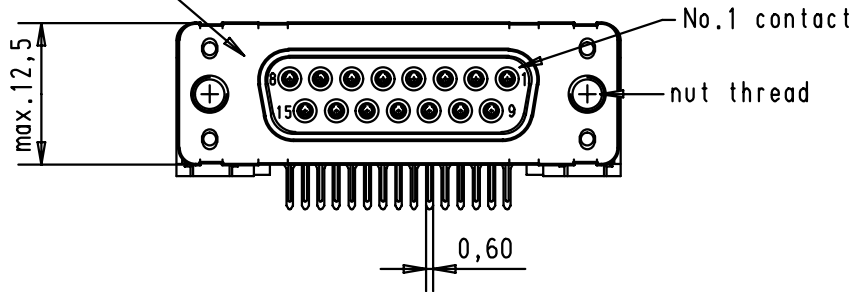

A

09 66 212 6601	M 3	2			
09 66 212 7601	M 3	3			
09 66 212 5601	M 3	0.76 μm Au			
09 66 212 6602	4-40 UNC	2			
09 66 212 7602	4-40 UNC	3	29773	18-APR-02	CV
09 66 212 5602	4-40 UNC	0.76 μm Au	27960	27/nov/00	ALSPACE
Part number	Nut thread	Performance level	Mod.	Dat.	Name

	Dat.	Name
Detail.	27/nov/00	ALSPACE
Insp.		
Stand.		

All Dim. in mm  
Orig. Size DIN A 4

HARTING EURL  
F-95972 Paris

D-Sub 15 poles standard angle female, solder pin with nut and hole

Maßstab/  
Scale  
1.5:1

TB 0966212x60x

Blatt/ Page  
2

Sub.