

## 26" PRO35™ TOOL CHEST 3 DRAWERS RED



- Fully extendable drawers capable of holding 30 kg, featuring smooth running ball bearing slides
- Protective EVA mats in each drawer
- Heavy gauge steel construction, enhanced by a 5-step phosphate-free rust prevention process and a powder coat finish
- Includes a 3-digit combination lock and is equipped with recessed handles and non-slip rubber feet
- Fully compatible with the TengTools Tool Control System for customized tool arrangement

The TengTools 26" PRO35™ tool chest TSM26R3 in matte red is a high-quality storage unit designed for professional workspaces. Measuring 660 mm wide, 305 mm deep, and 250 mm high, it is a space-saving addition to any workshop. This tool chest features three fully extendable drawers: two with a height of 50 mm and one with a height of 75 mm. Each drawer, measuring 569 mm wide and 275 mm deep, can hold up to four TengTools TC1 modules, making it compatible with the TengTools tool control system. Users can choose between the compact TT sets or the protective FOAM sets modules in high-density EVA with three layers. Durability and ease of use are key features. Each drawer supports up to 30 kg and has smooth running ball bearing slides. Aluminium drawer handles provide a comfortable grip, enhancing the user experience. Each drawer is lined with an EVA mat, offering additional protection for tools and minimizing noise during transport and operation. The tool chest includes recessed side handles for easy repositioning and rubber feet to protect the surface underneath from scratches. A 3-digit combination lock secures your tools, with an optional key lock available (not included). Constructed from heavy gauge, top-quality steel, this unit is built to withstand daily professional use. Its durability is enhanced by a 5-step phosphate-free rust prevention process, offering resistance to corrosion.

### General information

**Country of origin:** Taiwan  
**Barcode:** 5020385215153  
**Tarriff code Europe:** 9403208000  
**ECCN US:** EAR99  
**UNSPSC:** 24112401

### Dimensions

**Net weight (g):** 13000  
**Width (mm):** 660  
**Depth (mm):** 305  
**Height (mm):** 250  
**Number of drawer:** 3  
**Drawer capacity:** 3 × 30 kg  
**Drawer depth:** 3 × 275 mm  
**Drawer height:** 2 × 50 mm, 1 × 75 mm  
**Drawer width:** 3 × 569 mm

### Attributes

**Product type:** Mobile Tool Storage  
**Colour:** Red  
**Type of storage:** Tool Chest

### Features



Technical changes and errors may occur. 01-08-2024 20:00



**DESIGNED IN SWEDEN**

TengTools is a Swedish company present in more than 30 markets worldwide, and offers hand tools in smart storage solutions for demanding professionals within the automotive, maintenance and engineering sectors, as well as motor sport enthusiasts who aspire to use the same tools as top mechanics across the globe.



Sandbergsvägen 3  
 441 39 Alingsås, Sweden

# SPARE PART LIST

TSM26R3  
Version: 3



WWW.TENGTTOOLS.COM

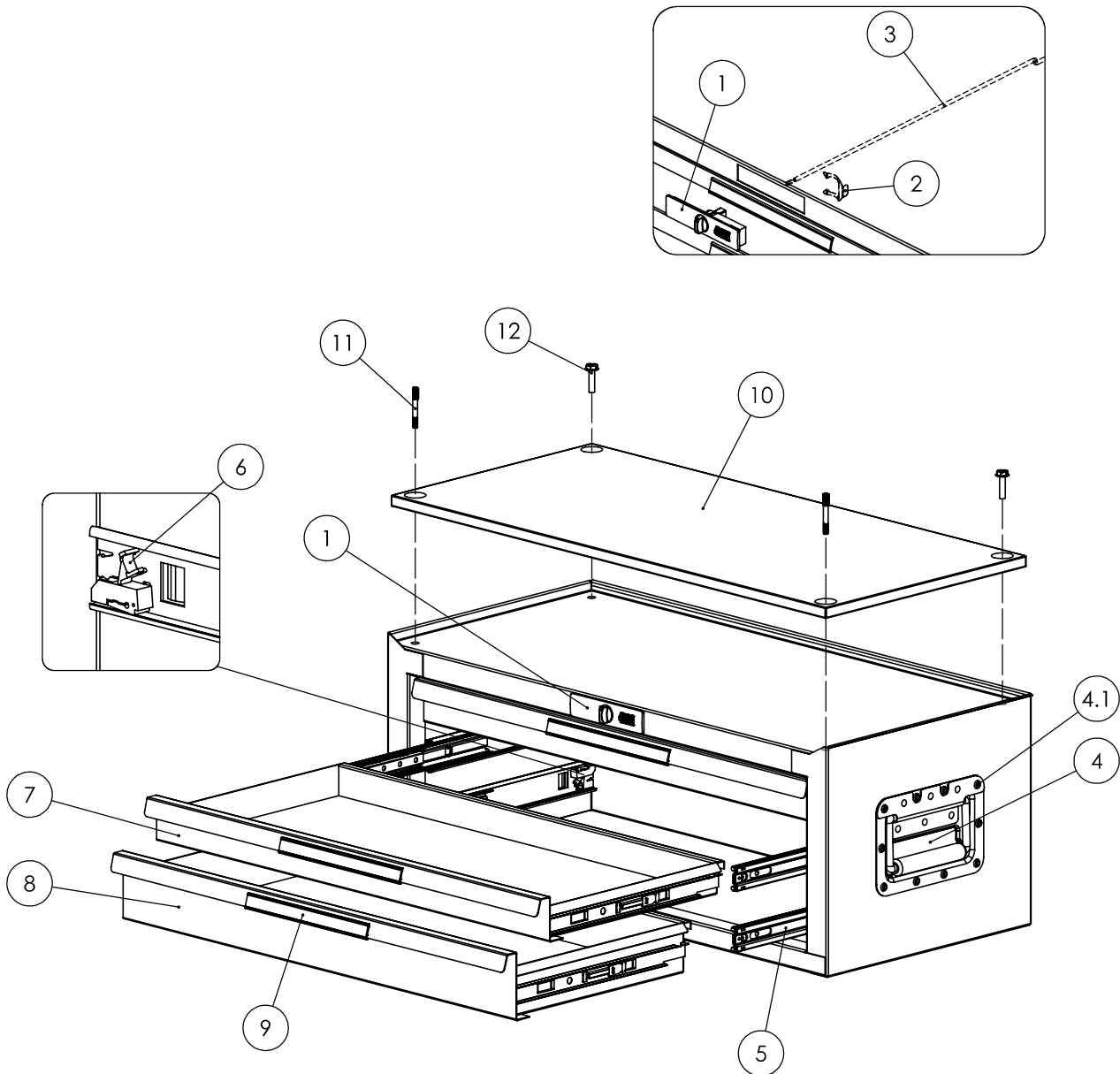

POS	DESCRIPTION	ITEM ID
1A	Combination Lock 180°	TC-180CLOCK
1B	Key cylinder lock 180° (optional)	TC-180KEYLOCK
2	Cam for lock (included in Pos 1)	TC803-05
3	Locking bar	TC603-11
4	Retractable side handle	TCDSHA
4.1	Rivets: 4,8mm x 7,4mm Black (10 pcs)	-
5	Slider 10" 36 mm Left/Right (1pc)	TC803N-03
6	Clip for sliders (included in Pos 5)	TC803N-13
7	Drawer 569 x 275 x 50 mm Red	TST26R-50
8	Drawer 569 x 275 x 75 mm Red	TST26R-75
9A	Aluminium drawer handle (3 pcs)	ALUE803
9B	Aluminium drawer handle (4 pcs)	ALUE804
10	Foam between middle & top box	TC603-10
11*	Screw pin for top box (1 pc)	TC603-09
12*	Screws for top box M6 x 25 mm (2 pcs)	-

\* Pos. 11 & 12 only used together with TST26R4