

THIS DRAWING IS UNPUBLISHED. RELEASED FOR PUBLICATION
 © COPYRIGHT - BY TYCO ELECTRONICS CORPORATION. ALL RIGHTS RESERVED.

LOC	DIST	REVISIONS					
GP	00	P	LTR	DESCRIPTION	DATE	DWN	APVD
		G		REVISE PER 06-008555 ECO	28/APR/06	ECC	FDM

- NOTES:
- △ PITCH TOLERANCE TO BE ±.18[.007] FOR 1.27[.050] PITCH JUMPERS & ±.25[.010] FOR ALL REMAINING PITCHES. TOLERANCE TO BE NON CUMULATIVE OVER GAUGE LENGTH.
 - △ 11.92-152.40[.500-6.000] ARE STANDARD LENGTHS. JUMPERS ARE AVAILABLE IN INCREMENTS OF 2.50[.10] PLUS 6.35[.25] AND 19.05[.75].
 - △ DELETED
 - △ FOR CONDUCTOR PITCH 7 (2mm), ON PAGE 2 & 3, DIMENSION "B" IS 2.00[.079]
 - △ SPECIAL PIN LENGTHS ARE AVAILABLE FOR JUMPERS WITH A PIN CONFIGURATION OF "A" OR "B" ON LENGTHS OF UP TO 609.6[24.0] IN 2.54[.100] & 5.08[.200] PITCH VARIANTS ONLY BY ADDING THE FOLLOWING SUFFIXES:

SUFFIX	PEN LENGTH	TOLERANCE
V1	2.85 (.112)	±.305 [±.012]
V2	3.40 (.134)	
V3	4.10 (.161)	
V4	6.50 (.256)	
V5	3.10 (.122)	
V6	2.81 (.150)	
V7	4.50 (.177)	
V8	2.00 (.079)	
V9	TBD	
V10	.76 (.030)	
V11	2.41 (.095)	

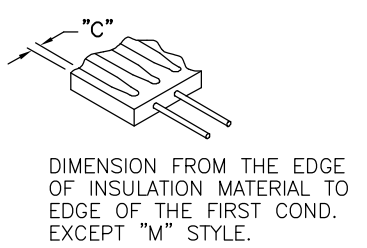

6. RECOMMENDED PCB HOLE DRILLING DETAILS ARE AS FOLLOWS:-

PITCH A	ØG
1.27 (.050)	.70 (.028)
1.90 (.075)	.80 (.031)
2.54 (.100)	.95 (.037)
3.18 (.125)	.95 (.037)
3.81 (.150)	.95 (.037)
5.08 (.200)	.95 (.037)

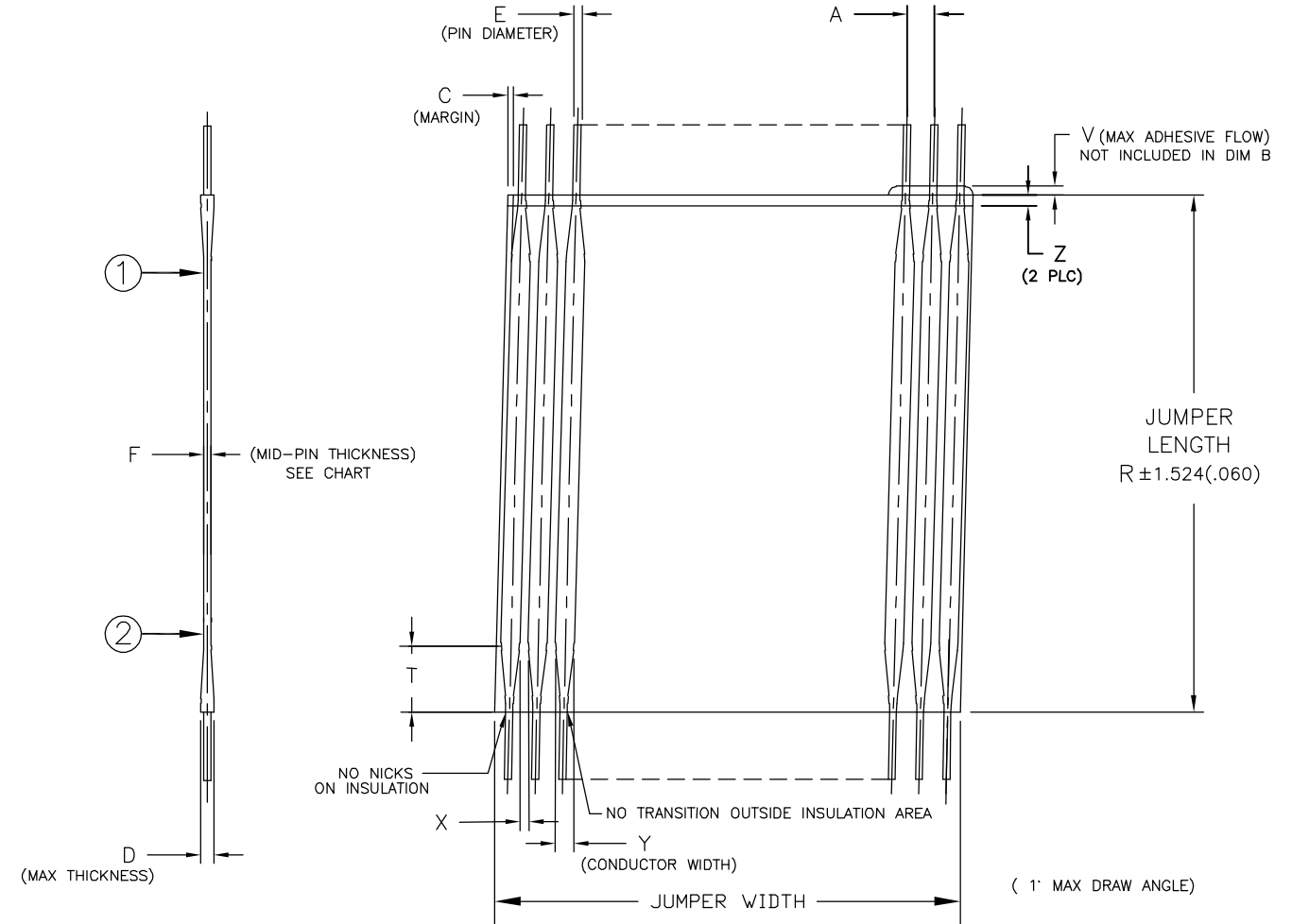
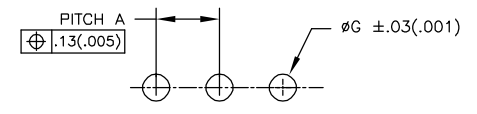

JUMPER LENGTH	PITCH (NOMINAL)	TRANSITION MAX	MAX/MIN MARGIN	△ PIN DIAMETER	WIRE GAUGE (AWG)	MIN/MAX No OF CONDUCTORS	MAXIMUM ADHESIVE FLOW	MIN GAP BETWEEN CONDUCTORS	CONDUCTOR WIDTH	MAXIMUM INSULATION MISMATCH	MAX THICKNESS
R △	A △	T	C	E	-	-	V	X	Y	Z	D
11.93 (.50) TO 863.6 (30.00)	1.00 (0.039)	4.32 [.170]	0.35 (.014) 0.17 (.007)	0.330 (.0130) 0.317 (.0125)	28	2-70	0.38 (0.015)	0.13 (0.009)	0.76 (.030) 0.56 (.022)	.76 (.030)	.64
	1.25 (0.049)	4.32 [.170]	0.50 (0.020) 0.17 (0.007)	0.330 (0.0130) 0.317 (0.0125)	28	2-70	0.38 (0.015)	0.25 (0.010)	0.89 (.035) 0.64 (.025)	.76 (.030)	.64
IN STEPS OF 2.50 (.10)	1.27 (0.050)	4.32 [.170]	0.50 (0.020) 0.17 (0.007)	0.330 (0.0130) 0.317 (0.0125)	28	2-70	0.38 (0.015)	0.25 (0.010)	0.89 (.035) 0.64 (.025)	.76 (.030)	.64
	2.00 (0.079)	5.08 [.200]	0.70 (0.028) 0.25 (0.010)	0.416 (0.0164) 0.400 (0.0157)	26	2-50	0.38 (0.015)	0.38 (0.015)	1.14 (.045) 0.89 (.035)	.76 (.030)	.84
PLUS 6.35 (.25)	1.90 (0.075)	5.08 [.200]	0.70 (0.028) 0.25 (0.010)	0.416 (0.0164) 0.400 (0.0157)	26	2-50	0.38 (0.015)	0.38 (0.015)	1.14 (.045) 0.89 (.035)	.76 (.030)	.84
	2.54 (0.100)	6.35 [.250]	0.80 (0.031) 0.25 (0.010)	0.526 (0.0207) 0.505 (0.0199)	24	2-50	0.51 (0.020)	0.51 (0.020)	1.52 (.060) 1.27 (.050)	.76 (.030)	.84
AND 19.05 (.75)	3.18 (0.125)	6.35 [.250]	1.00 (0.039) 0.25 (0.010)	0.526 (0.0207) 0.505 (0.0199)	24	2-25	0.51 (0.020)	0.51 (0.020)	1.52 (.060) 1.27 (.050)	.76 (.030)	.84
	3.81 (0.150)	6.35 [.250]	1.00 (0.039) 0.25 (0.010)	0.526 (0.0207) 0.505 (0.0199)	24	2-20	0.51 (0.020)	0.51 (0.020)	1.52 (.060) 1.27 (.050)	.76 (.030)	.84
	5.08 (0.200)	6.35 [.250]	1.00 (0.039) 0.25 (0.010)	0.526 (0.0207) 0.505 (0.0199)	24	2-15	0.51 (0.020)	0.51 (0.020)	1.52 (.060) 1.27 (.050)	.76 (.030)	.84

- △ BEND RADIUS TO APPLY ONLY IN THE FLAT SECTION OF JUMPER BETWEEN THE CONDUCTOR TRANSITION AREAS.
- △ PER 108-2135.
- 9. TOOL MARKS PERMISSIBLE ON BENDS. NO EXPOSED COPPER.
- △ PIN DIAMETER SPECIFIED NOT APPLICABLE IN BENDING AREA OF PIN, DUE TO NORMAL DEFORMATION OF BENDING PROCESS.
- △ REFER TO RELEVANT MATERIAL SPECIFICATIONS.

F - MID POINT THICKNESS BETWEEN PT 1 & PT 2	MINIMUM		MAXIMUM	
NOMEX	.152 [.006]	.305 [.012]		
POLYESTER	.152 [.006]	.305 [.012]		
KAPTON	.102 [.004]	.254 [.010]		
TEFLON	.305 [.012]	.533 [.021]		

12. PRODUCT AND PROCESSING MUST MEET REQUIREMENTS OF TYCO ELECTRONICS STANDARD 230-702.

THIS DRAWING IS A CONTROLLED DOCUMENT.

DWN J. SCHWARTZ 28FEB01
 CHK E. FOX 28FEB01
 APVD E. FOX 28FEB01

tyco Electronics Tyco Electronics Corporation Harrisburg, Pa. 17105

NAME FLEXSTRIP PIN CONFIGURATIONS, GENERIC

PRODUCT SPEC - APPLICATION SPEC -

SIZE A3 CAGE CODE 00779 DRAWING NO C-1474339 RESTRICTED TO -

SCALE N.T.S. SHEET 1 OF 4 REV G

CUSTOMER DRAWING

THIS DRAWING IS UNPUBLISHED. RELEASED FOR PUBLICATION
 © COPYRIGHT - BY TYCO ELECTRONICS CORPORATION. ALL RIGHTS RESERVED.

LOC GP DIST 00

REVISIONS					
P	LTR	DESCRIPTION	DATE	DWN	APVD
	-	SEE SHEET 1	-	-	-

A - STRAIGHT PINS

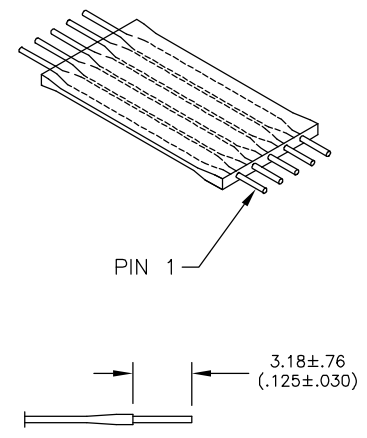

B - RIGHT ANGLE PINS (BENT DOWN)

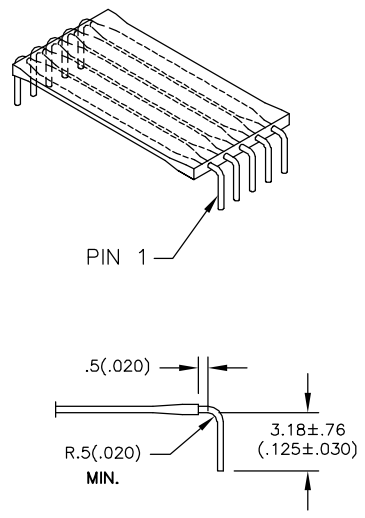

C - RIGHT ANGLE STAGGERED PINS (PIN 1 SHORT, BENT DOWN)

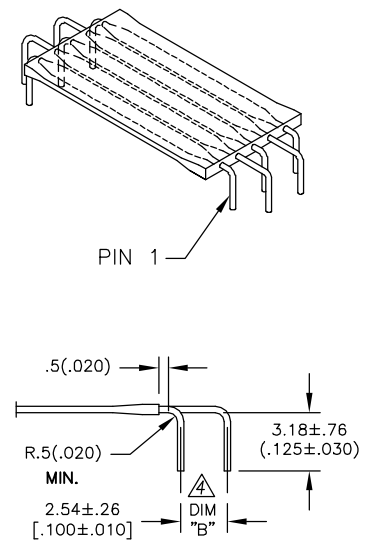

D - STRAIGHT ANGLE STAGGERED PINS (PIN 1 STRAIGHT)

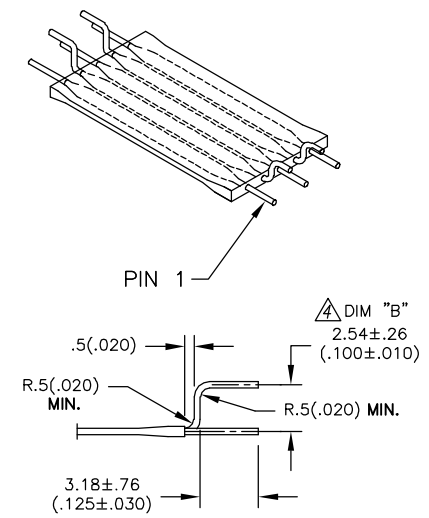

STANDARD JUMPERS ORDERING CODE/CATALOGUE NUMBER

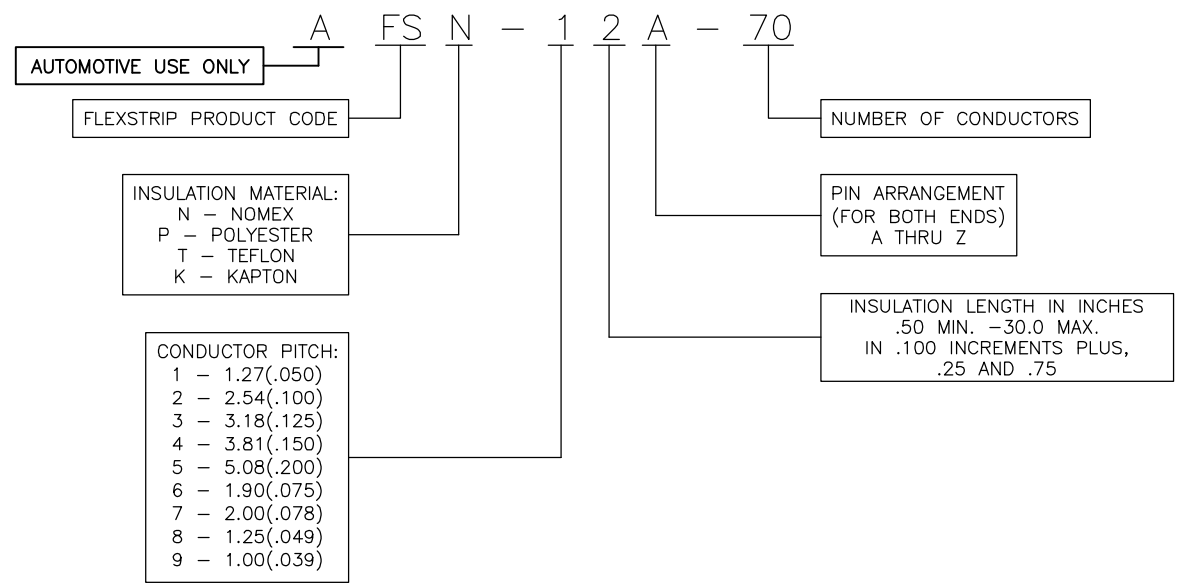

MANUFACTURING NOTE: MINIMUM GAP BETWEEN STRIPS

SK/A/Z	.75 INCH
LP	1.1 INCH

MINIMUM CONDUCTOR COUNT PER STRIP FOR LINE JOBS

PITCH	CONDUCTOR
1 1.27 (.050)	60
2 2.54 (.100)	60
3 3.18 (.125)	60
4 3.81 (.150)	50
5 5.08 (.200)	40
6 1.91 (.075)	60
7 2.0 (.078)	60
8 1.24 (.049)	60
9 1.0 (.039)	80

STANDARD LINE JOBS

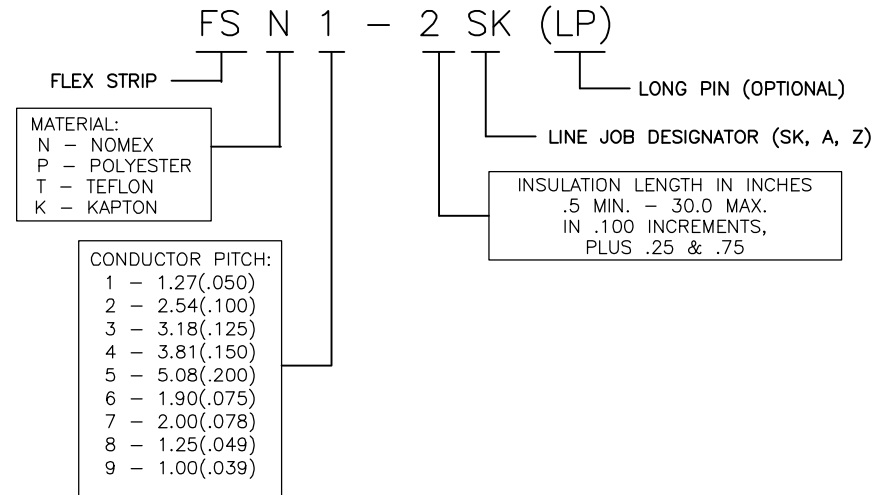

THE FOLLOWING ORDERING CODE IS A SPECIAL FOR TYCO GERMANY DESCRIBING A STRIP OF ANY INSULATION MATERIAL, ANY PITCH AND ANY INSULATION LENGTH WITH A 11.00[.433] MIN PIN LENGTH UNLESS OTHERWISE SPECIFIED:-

FS X-X X J-A A W

THIS DRAWING IS A CONTROLLED DOCUMENT.

DIMENSIONS: MM [INCHES]	TOLERANCES UNLESS OTHERWISE SPECIFIED:
	0 PLC ± -
	1 PLC ± -
	2 PLC ± -
	3 PLC ± -
	4 PLC ± -
	ANGLES ± 1/2°
MATERIAL	FINISH
-	-

DWN J. SCHWARTZ	28FEB01
CHK E. FOX	28FEB01
APVD E. FOX	28FEB01
PRODUCT SPEC	-
APPLICATION SPEC	-
WEIGHT	-
CUSTOMER DRAWING	

tyco Electronics		Tyco Electronics Corporation Harrisburg, Pa. 17105	
NAME FLEXSTRIP PIN CONFIGURATIONS, GENERIC			
SIZE	CAGE CODE	DRAWING NO	RESTRICTED TO
A3	00779	C-1474339	-
SCALE N.T.S.		SHEET 2 OF 4	REV G

THIS DRAWING IS UNPUBLISHED. RELEASED FOR PUBLICATION
 © COPYRIGHT - BY TYCO ELECTRONICS CORPORATION. ALL RIGHTS RESERVED.

LOC	DIST	REVISIONS					
GP	00	P	LTR	DESCRIPTION	DATE	DWN	APVD
		-		SEE SHEET 1	-	-	-

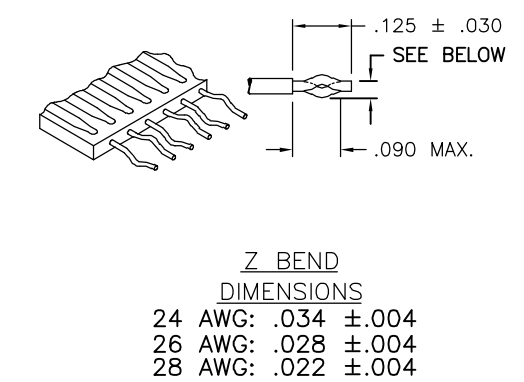
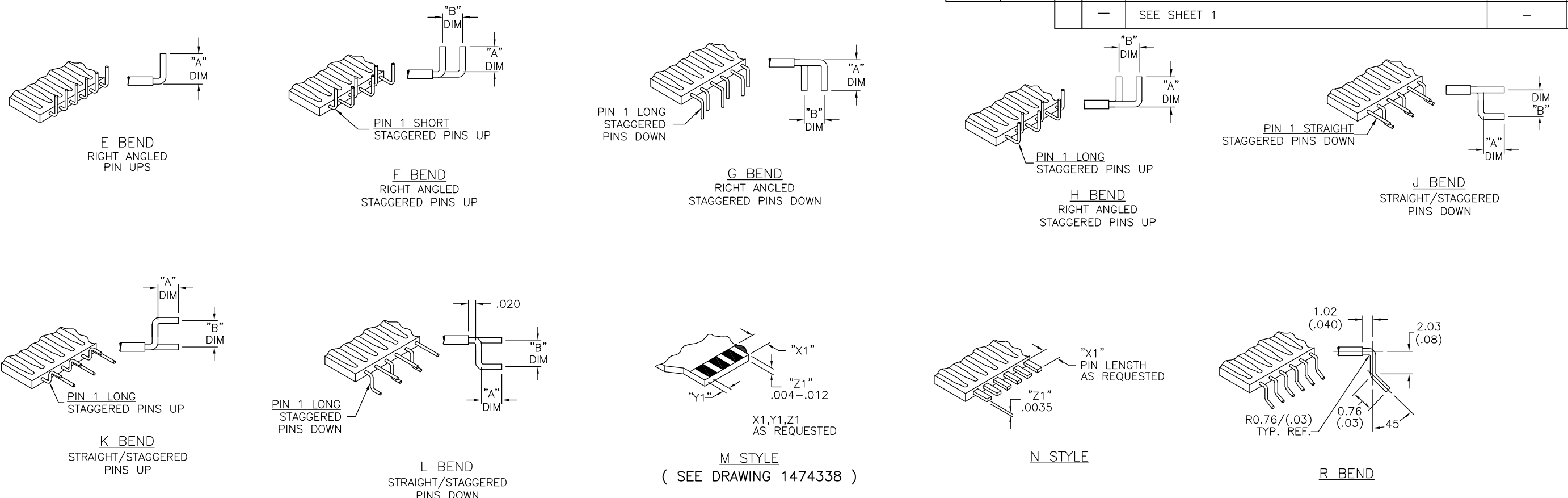

SPECIAL JUMPERS ORDERING CODE/CATALOGUE NUMBER

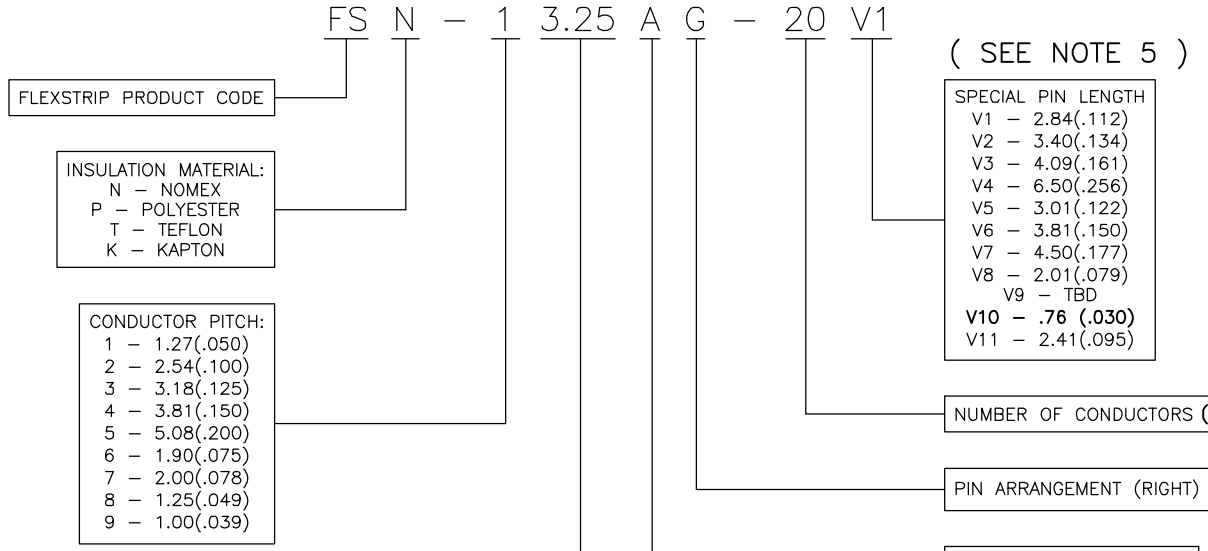

CONDUCTOR PITCH	BENDS AVAILABLE
1 - 1.27/(.050)	E,F,G,H,J,K,L,M
2 - 2.54/(.100)	E,F,G,H,J,K,L,R,M
3 - 3.18/(.125)	E
4 - 3.81/(.150)	E
5 - 5.08/(.200)	E
6 - 1.91/(.075)	E,F,G,H,J,K,L
7 - 2.00/(.0787)	E,F,G,H,J,K,L
8 - 1.25/(.049)	E
9 - 1.00/(.039)	E, M

SPECIAL FLEXSTRIP BENDS
 SPECIAL FLEXSTRIP BENDS E THRU R, AND Z MAY APPLY TO EITHER LEFT OR RIGHT SIDE

INSULATION LENGTH: (in inches)
 .50 MIN. - 30.0 MAX.
 IN .10 INCREMENTS PLUS .25 AND .50

E THRU L BEND
"A" DIM
3.18±0.76/(.125±.030)
"B" DIM
2.54±0.25/(.100±.010)

THIS DRAWING IS A CONTROLLED DOCUMENT.		DWN J. SCHWARTZ 28FEB01	Tyco Electronics Corporation Harrisburg, Pa. 17105	
DIMENSIONS: MM [INCHES]		CHK E. FOX 28FEB01		
TOLERANCES UNLESS OTHERWISE SPECIFIED:		APVD E. FOX 28FEB01	NAME FLEXSTRIP PIN CONFIGURATIONS, GENERIC	
0 PLC ± - 1 PLC ± - 2 PLC ± - 3 PLC ± - 4 PLC ± - ANGLES ± 1/2°		PRODUCT SPEC -	SIZE CAGE CODE DRAWING NO RESTRICTED TO	
MATERIAL -		APPLICATION SPEC -	A3 00779 C-1474339	
FINISH -		WEIGHT -	CUSTOMER DRAWING SCALE N.T.S. SHEET 3 OF 4 REV G	

THIS DRAWING IS UNPUBLISHED. RELEASED FOR PUBLICATION
 © COPYRIGHT BY TYCO ELECTRONICS CORPORATION. ALL RIGHTS RESERVED.

LOC GP	DIST 00	REVISIONS		
P	LTR	DESCRIPTION	DATE	DWN
		SEE SHEET 1	-	-

NORMAL CONDUCTOR PITCH		1.00 (.039)	1.25 (.049)	1.27 (.050)	1.90 (.075)	2.00 (.078)	2.54 (.100)	3.18 (.125)	3.81 (.150)	5.08 (.200)	7.62 (.300)
WIRE GAUGE		AWG 28	AWG 28	AWG 28	AWG 26	AWG 26	AWG 24	AWG 24	AWG 24	AWG 24	AWG 24
NOMINAL WIRE DIAMETER		.32(.0126)	.32(.0126)	.32(.0126)	.40(.0159)	.40(.0159)	.51(.0201)	.51(.0201)	.51(.0201)	.51(.0201)	.51(.0201)
CURRENT RATING		1.0A	1.6A	1.6A	2.0A	2.0A	3.0A	3.5A	3.5A	4.0A	4.0A
VOLTAGE RATING		200VAC	200VAC	200VAC	200VAC	200VAC	300VAC	300VAC	300VAC	300VAC	300VAC
MAX NUMBER OF CONDUCTORS PER JUMPER		70	70	70	50	50	48	30	25	20	13
MIN BREAKDOWN VOLTAGE @ 1 MIN		1025VAC	1050VAC	1050VAC	1250VAC	1250VAC	1500VAC	1500VAC	1500VAC	1500VAC	1500VAC
INSULATION RESISTANCE (GND. SIG. GND) 305 (12') SAMPLE @ 500VDC	P N T K	△8	△8	△8	△8	△8	△8	△8	△8	△8	△8
CAPACITANCE (pf / 50.8 (12') LENGTH) (GND, SIG, GND) (AVERAGE)	P N T K	△8	△8	△8	△8	△8	△8	△8	△8	△8	△8
CHARACTERISTIC IMPEDANCE (GND. SIG. GND) (AVERAGE)	P N T K	△8	△8	△8	△8	△8	△8	△8	△8	△8	△8
APPLICATION TEMP RANGE (C°) (FOR SOLDERING)	P N T K	200 / 4 sec 200 / 4 sec 240 / 4 sec 240 / 4 sec	200 / 4 sec 200 / 4 sec 240 / 4 sec 240 / 4 sec	200 / 4 sec 200 / 4 sec 240 / 4 sec 240 / 4 sec	200 / 4 sec 200 / 4 sec 240 / 4 sec 240 / 4 sec	200 / 4 sec 200 / 4 sec 240 / 4 sec 240 / 4 sec	250 / 4 sec 250 / 4 sec 260 / 5 sec 260 / 5 sec	250 / 4 sec 250 / 4 sec 260 / 5 sec 260 / 5 sec	250 / 4 sec 250 / 4 sec 260 / 5 sec 260 / 5 sec	250 / 4 sec 250 / 4 sec 260 / 5 sec 260 / 5 sec	250 / 4 sec 250 / 4 sec 260 / 5 sec 260 / 5 sec
OPERATING TEMPERATURE (C°)	P N T K	-40 to 105 (For all Conductor Pitches) -40 to 125 (For all Conductor Pitches) -40 to 150 (For all Conductor Pitches) -40 to 150 (For all Conductor Pitches)									
MINIMUM BEND RADIUS	P N T K	3.18mm (For all Conductor Pitches) 3.18mm (For all Conductor Pitches) 3.18mm (For all Conductor Pitches) 3.18mm (For all Conductor Pitches)									
UL STYLE NUMBER	P N T K	2639 (For all Conductor Pitches .100 and above) 5188 (For all Conductor Pitches .100 and above) 2928 (For all Conductor Pitches .100 and above) 2927 (For all Conductor Pitches .100 and above)									

ABR.	MATERIAL	SPECIFICATION
	COPPER WIRE	100-1577
P	POLYESTER	100-1575
N	NOMEX	100-1758
T	TEFLON	100-1574
K	KAPTON	100-1576

THIS DRAWING IS A CONTROLLED DOCUMENT.		DWN J. SCHWARTZ 28FEB01	Tyco Electronics Corporation Harrisburg, Pa. 17105	
DIMENSIONS: MM [INCHES]		CHK E. FOX 28FEB01	NAME FLEXSTRIP PIN CONFIGURATIONS, GENERIC	
TOLERANCES UNLESS OTHERWISE SPECIFIED: 0 PLC ± - 1 PLC ± - 2 PLC ± - 3 PLC ± - 4 PLC ± - ANGLES ± 1/2'		APVD E. FOX 28FEB01	PRODUCT SPEC -	
MATERIAL -		FINISH -	APPLICATION SPEC -	RESTRICTED TO -
		WEIGHT -	SIZE A3	CAGE CODE 00779
		DRAWING NO C-1474339		SCALE N.T.S.
CUSTOMER DRAWING		SHEET 4 OF 4		REV G